

Pagan

Patterns

and

Designs

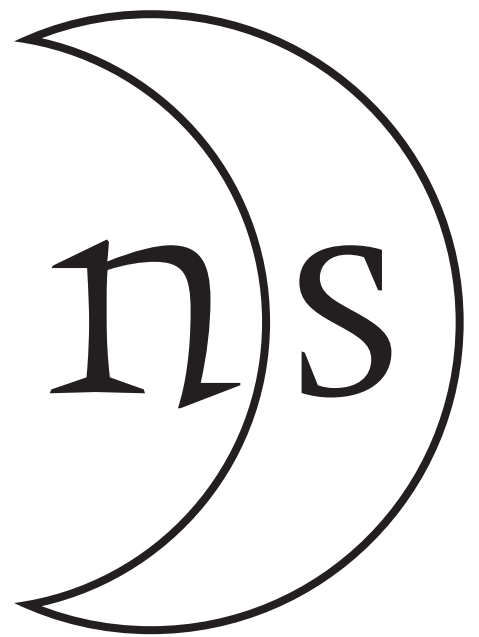
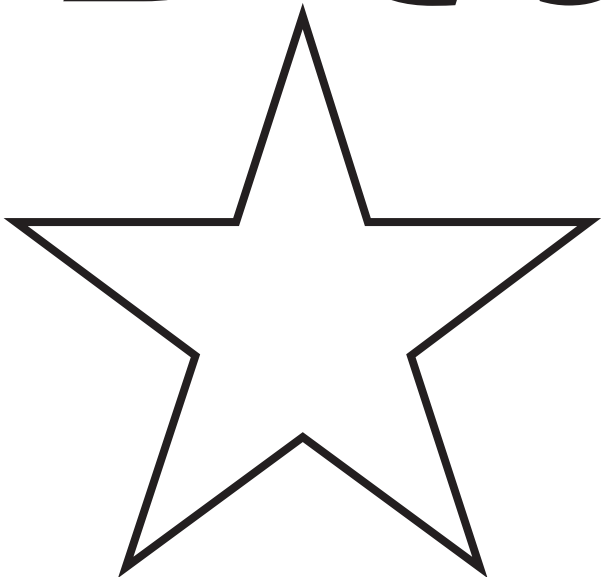

By Eliza Fegley

By Eliza Fegley

www.sacredspiral.com

With special thanks to Ravenfox. Without his help
this book would not be possible.

Ravenfox

<http://paganart.com>

Copyright © 2000 Eliza Fegley.

Published in Reading Pennsylvania 19606 USA.

Published by Rowan Press, Inc.

All rights reserved. No portion of the book may be reproduced or transmitted in any form or by any means electronic or mechanical, including any information storage or retrieval systems, without permission in writing from the publisher, except for brief passages which be quoted by a reviewer.

ISBN 1-890846-01-5

Printed in the United States of America

Pagan
Patterns
and
Designs

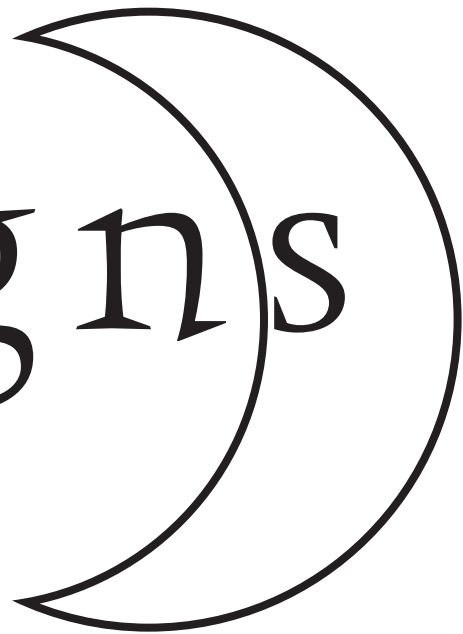

By Eliza Fegley

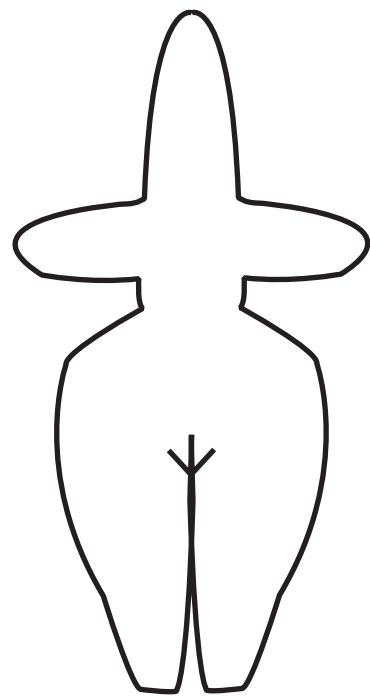
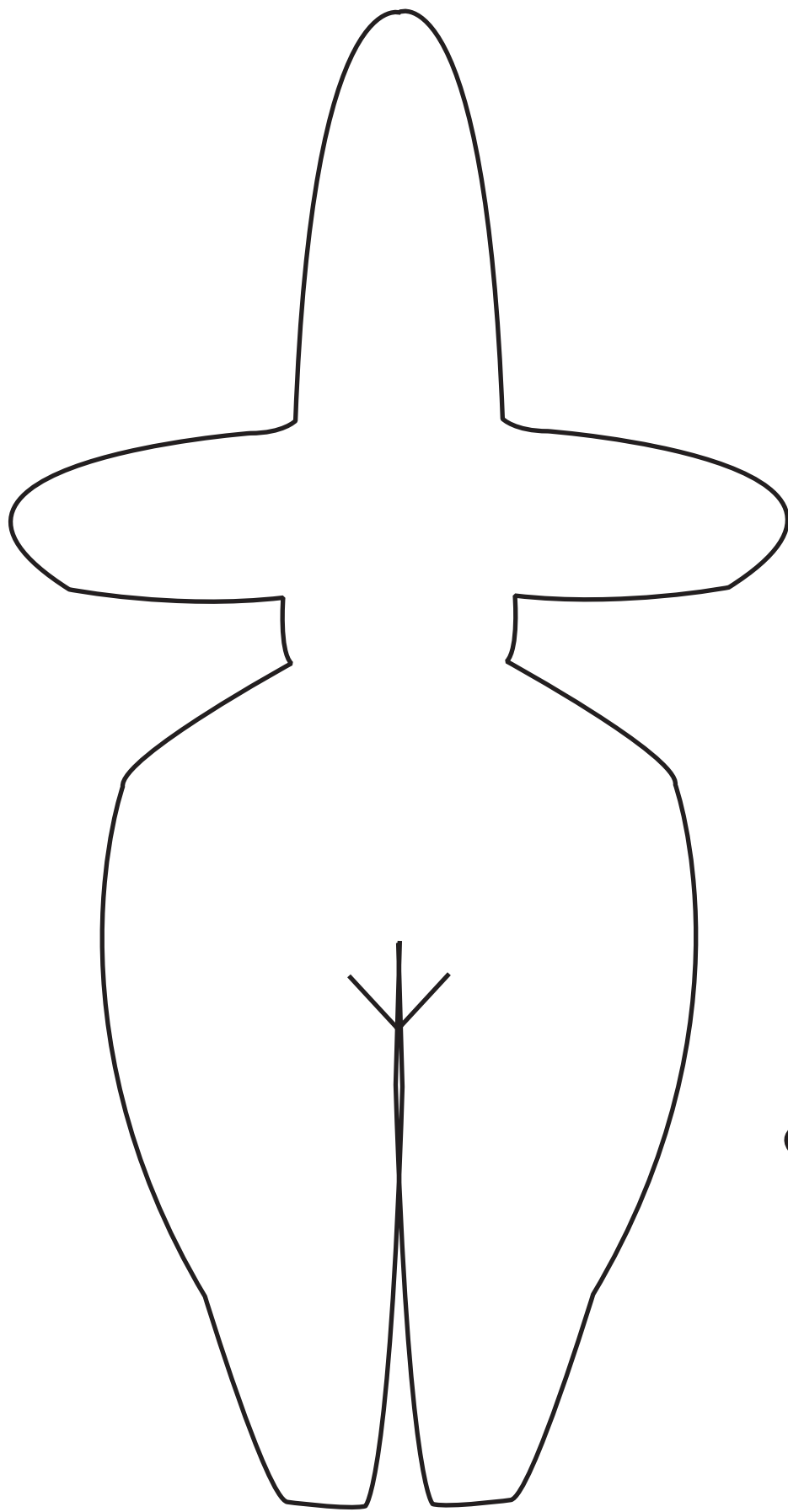

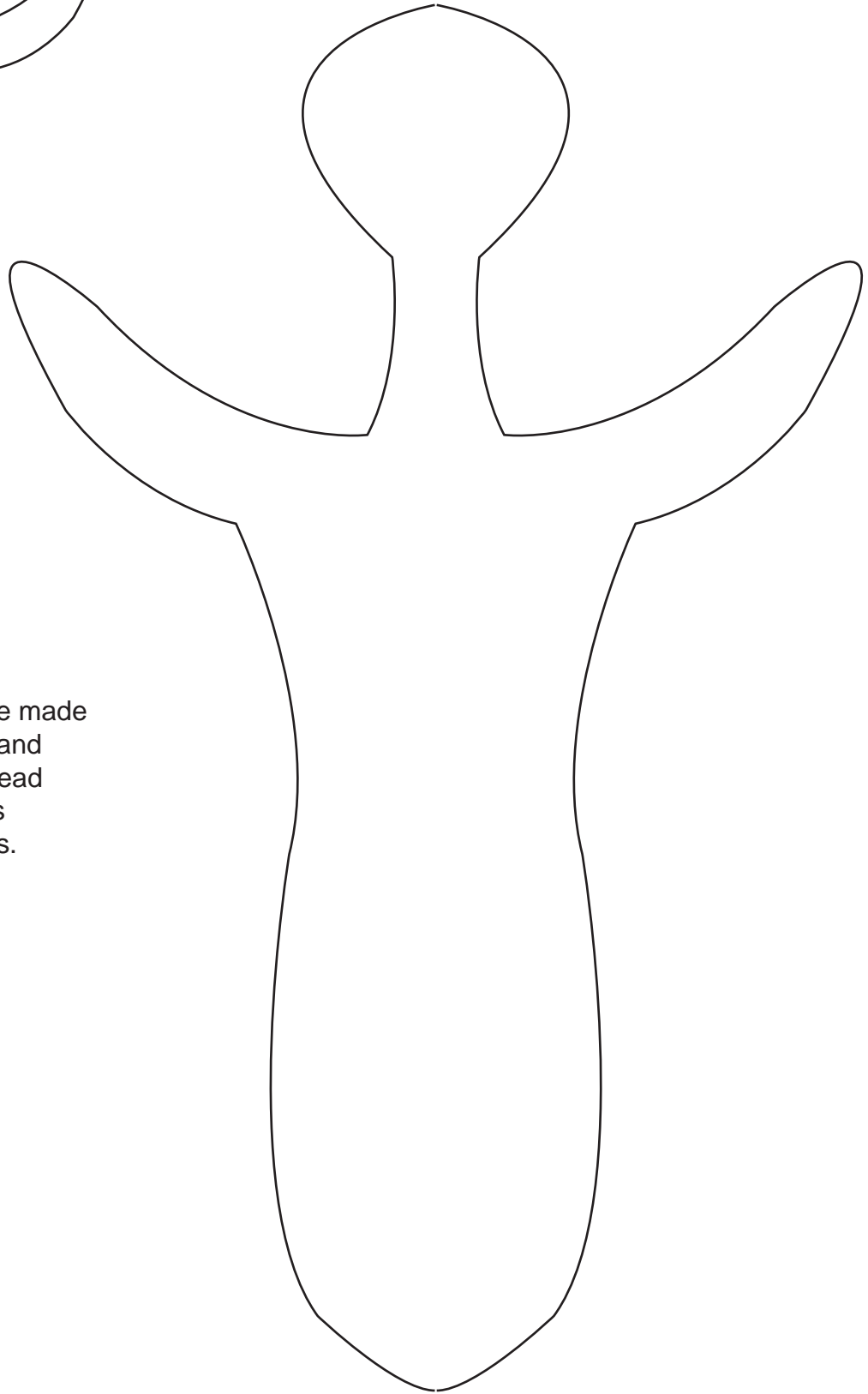
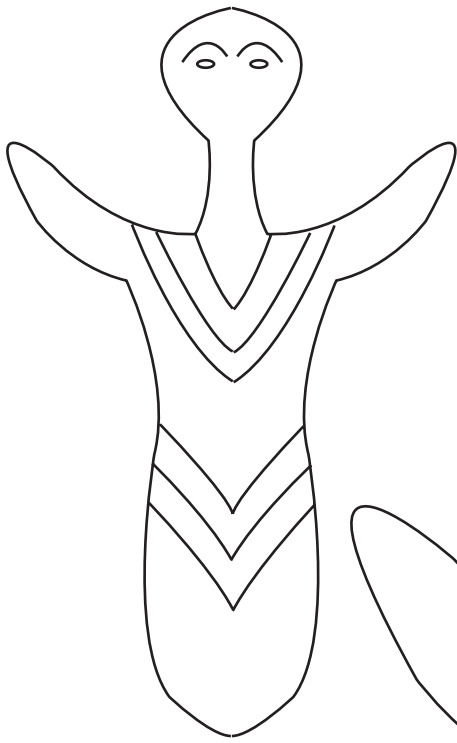

Patterns can be made into appliques and embroidery thread can be used as embellishments.

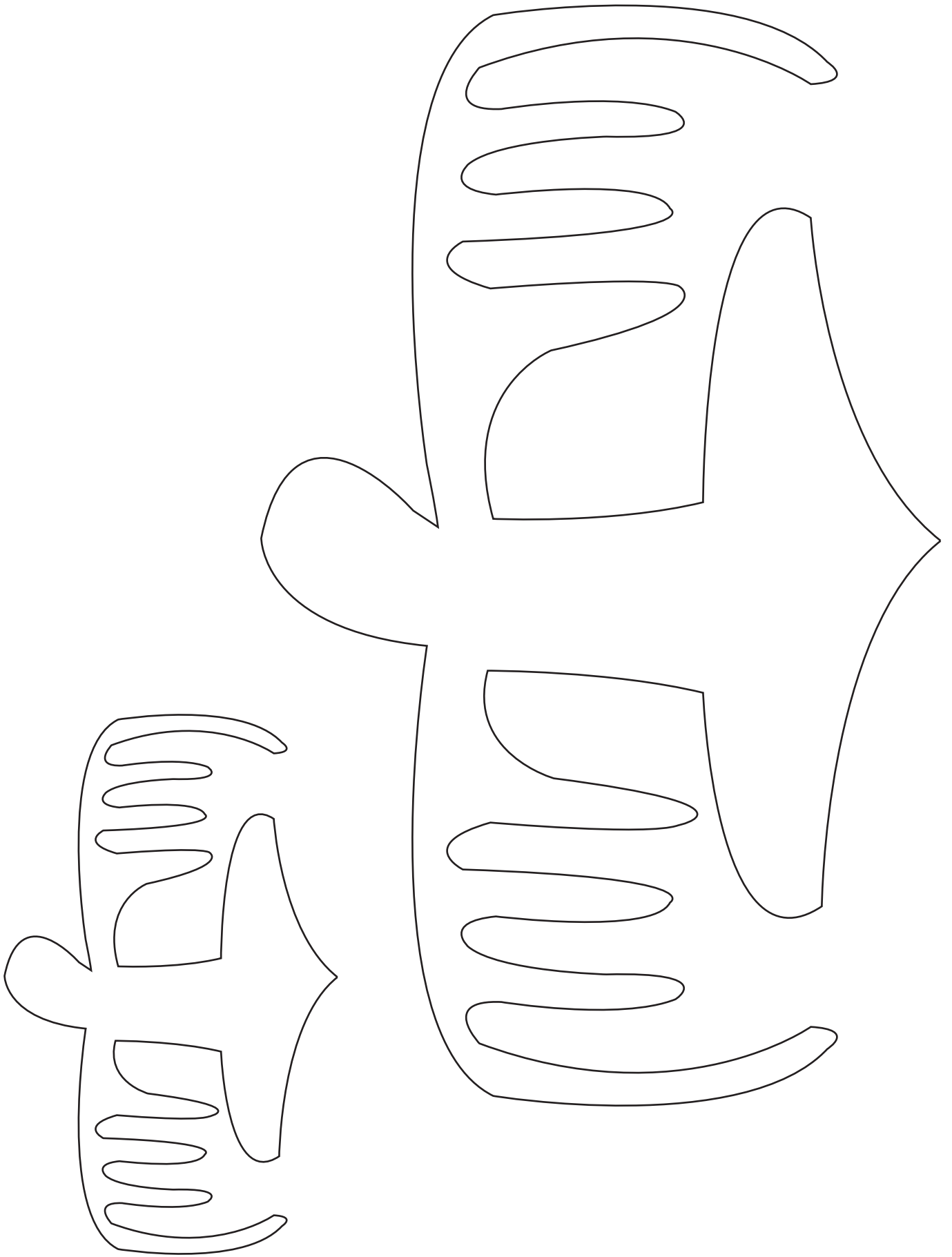

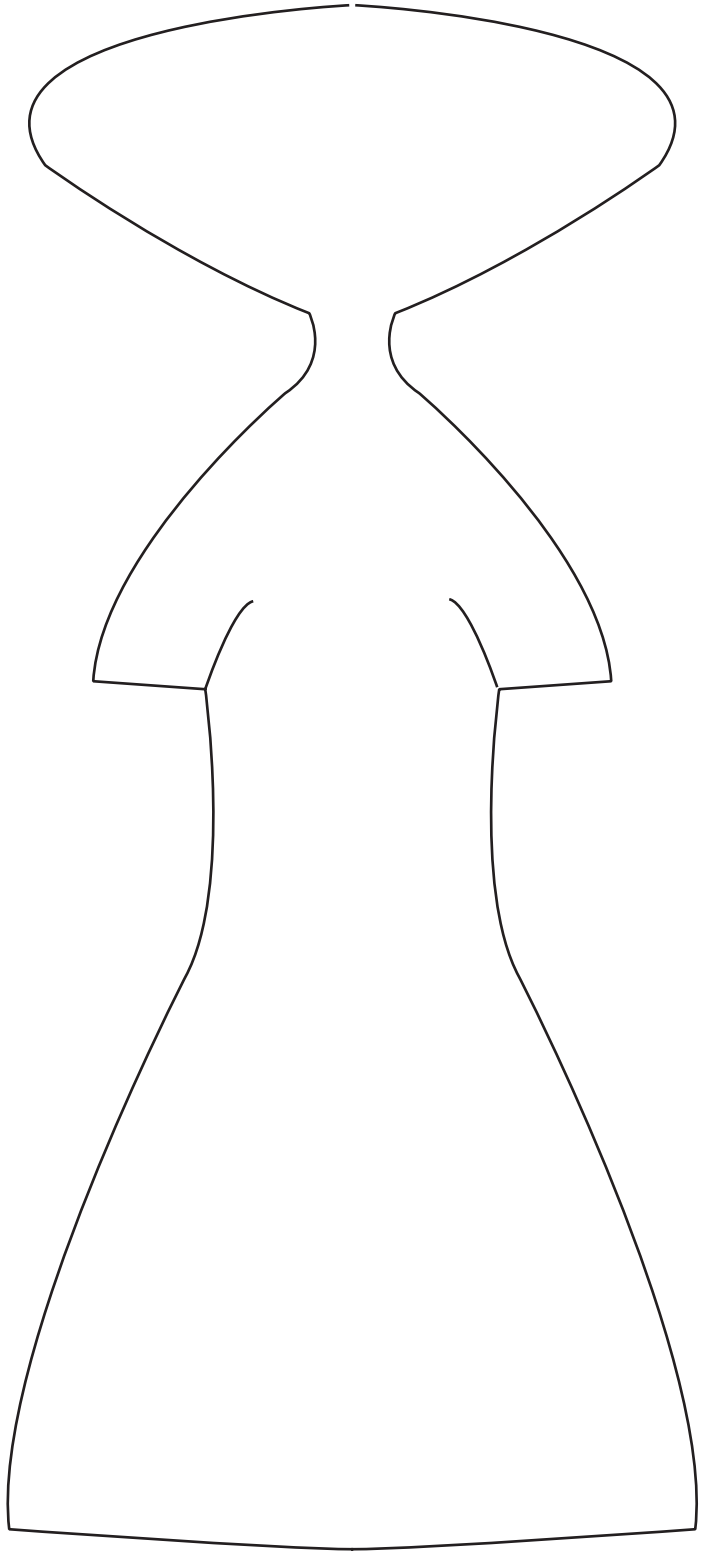
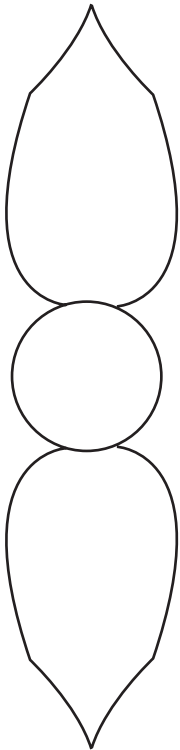
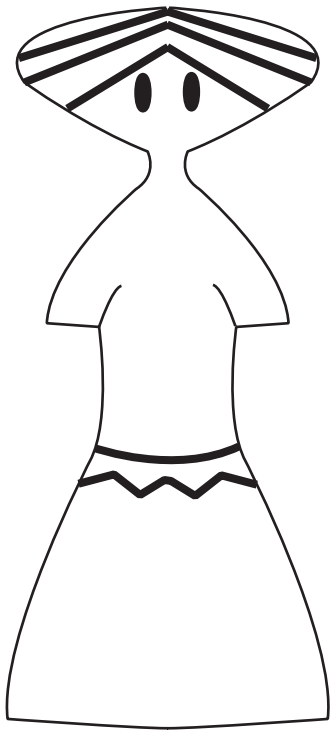

Altar cloths can be made by applying patterns onto a square piece of cloth. Felt works well for this and can be made into simple wall-hangings.

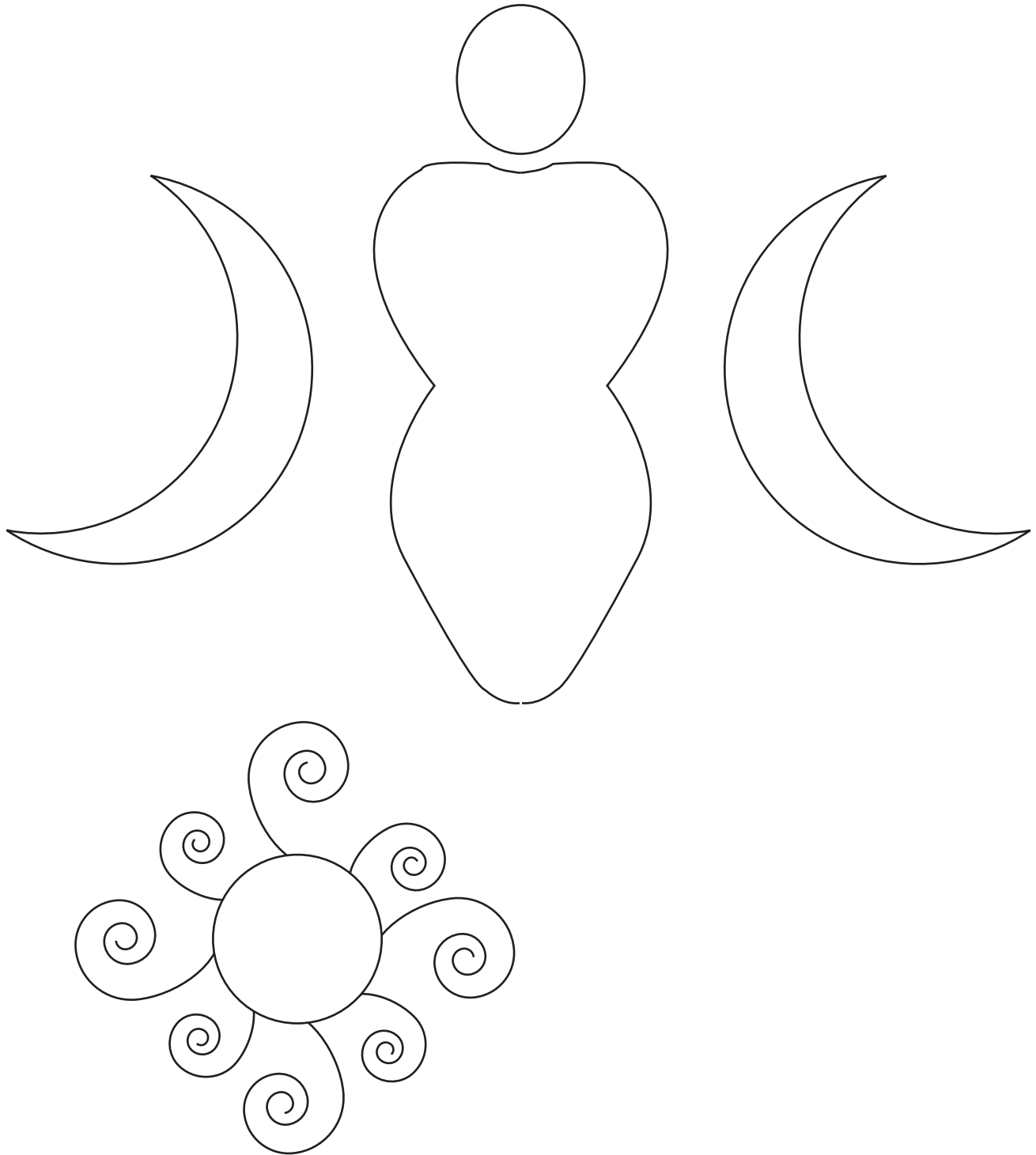

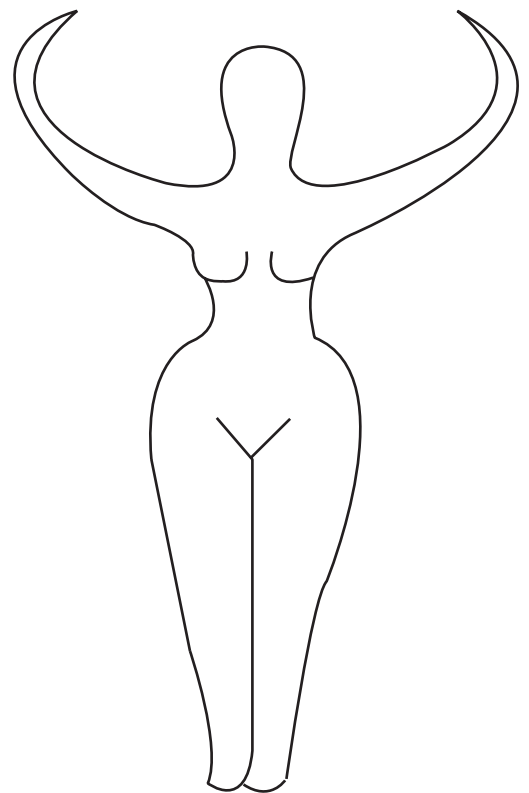
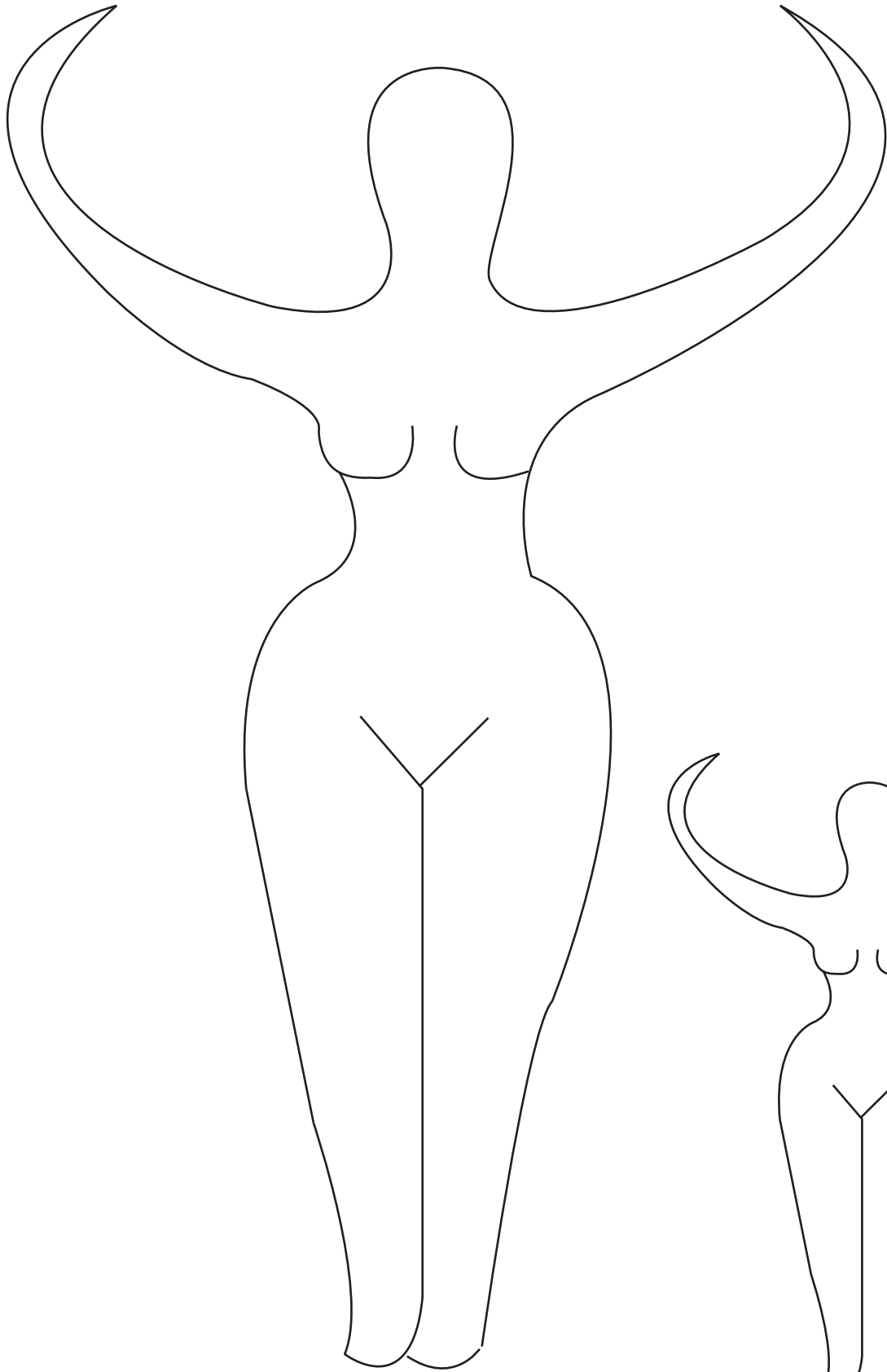

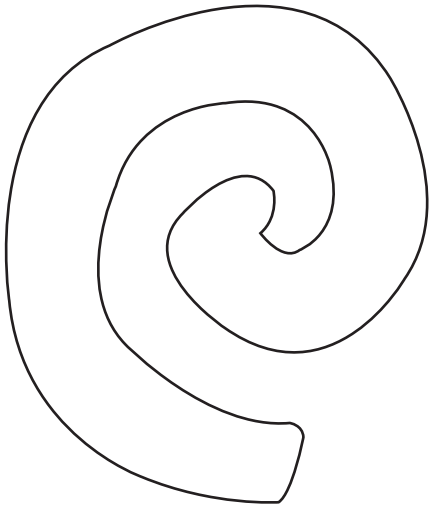
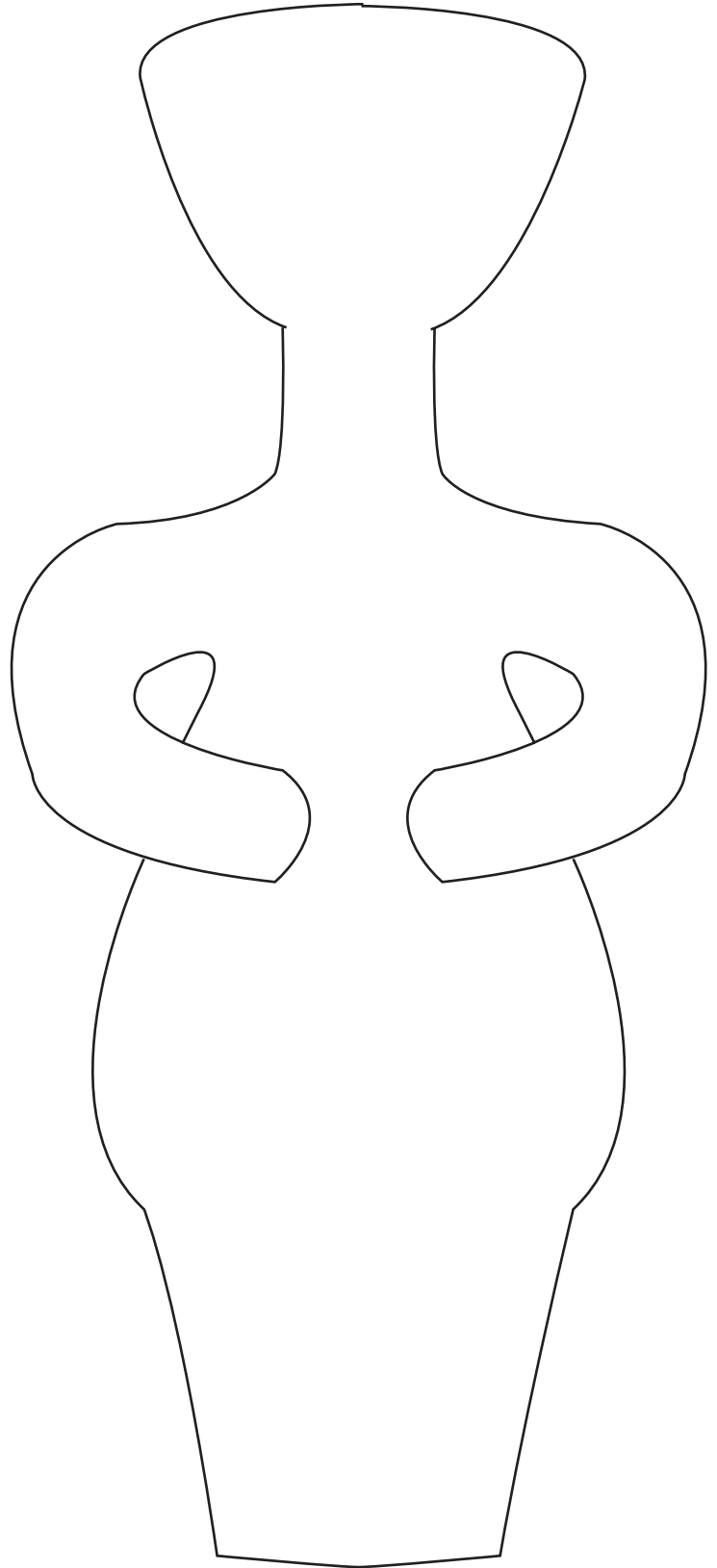
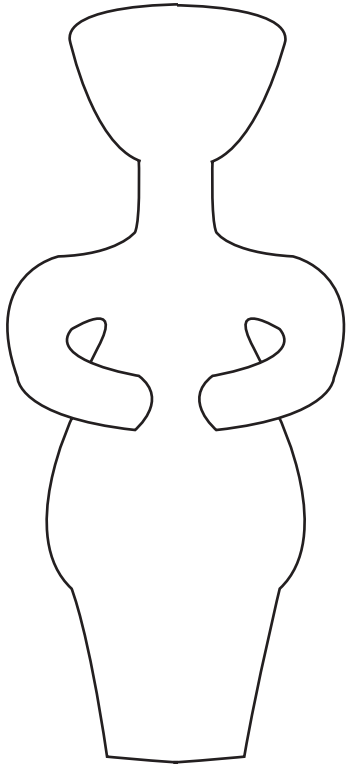

I have used the Goddess pattern on this page many times for making paper mache wall hangings. Just add two straight lines for Her neck and the pattern is in one piece.

Cut Her image out of either cardboard or pressed board. Cover her with 3 layers of stripped newspaper that have been dipped into a paper mache solution. This is usually an equal blend of water and flour or wallpaper paste.

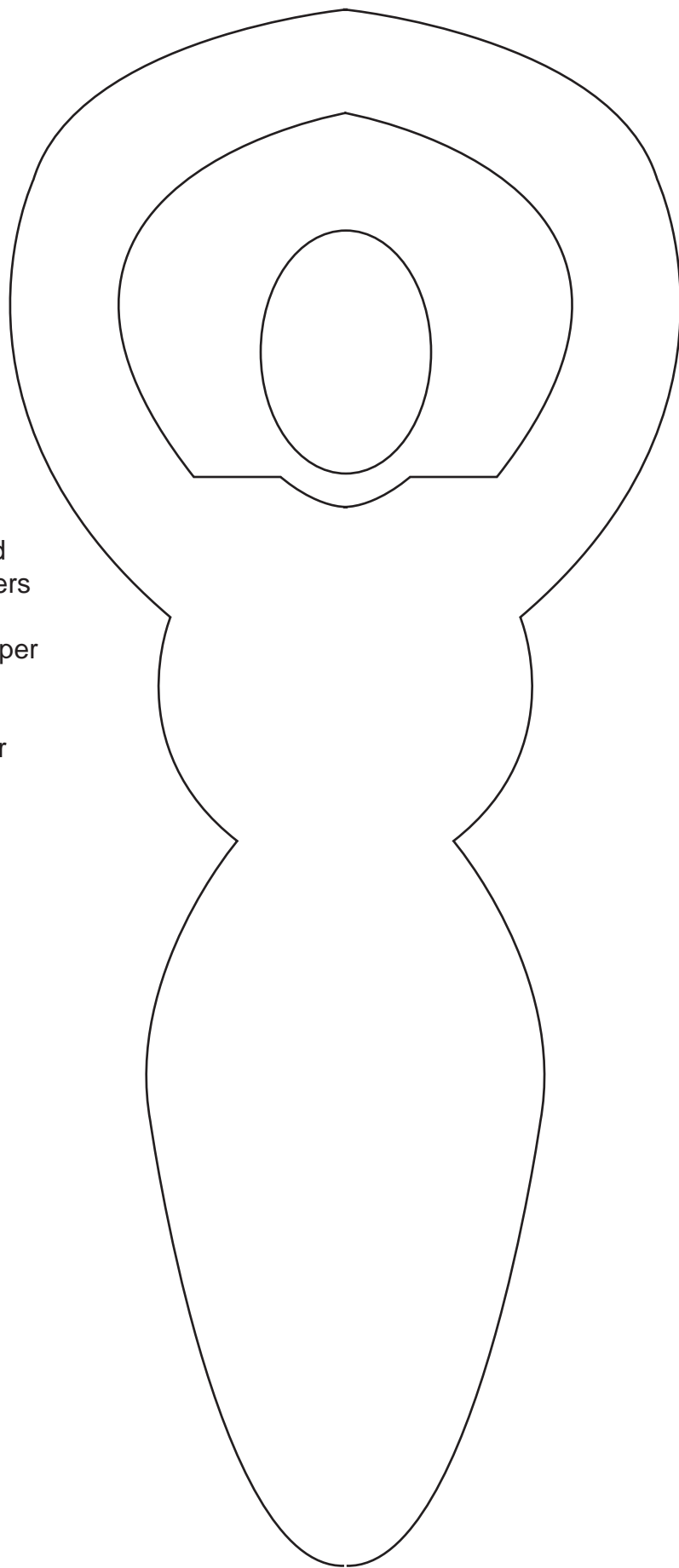
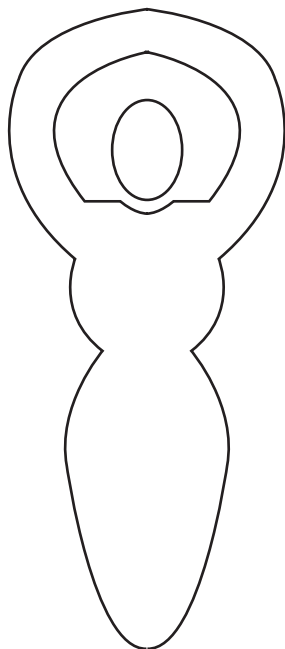

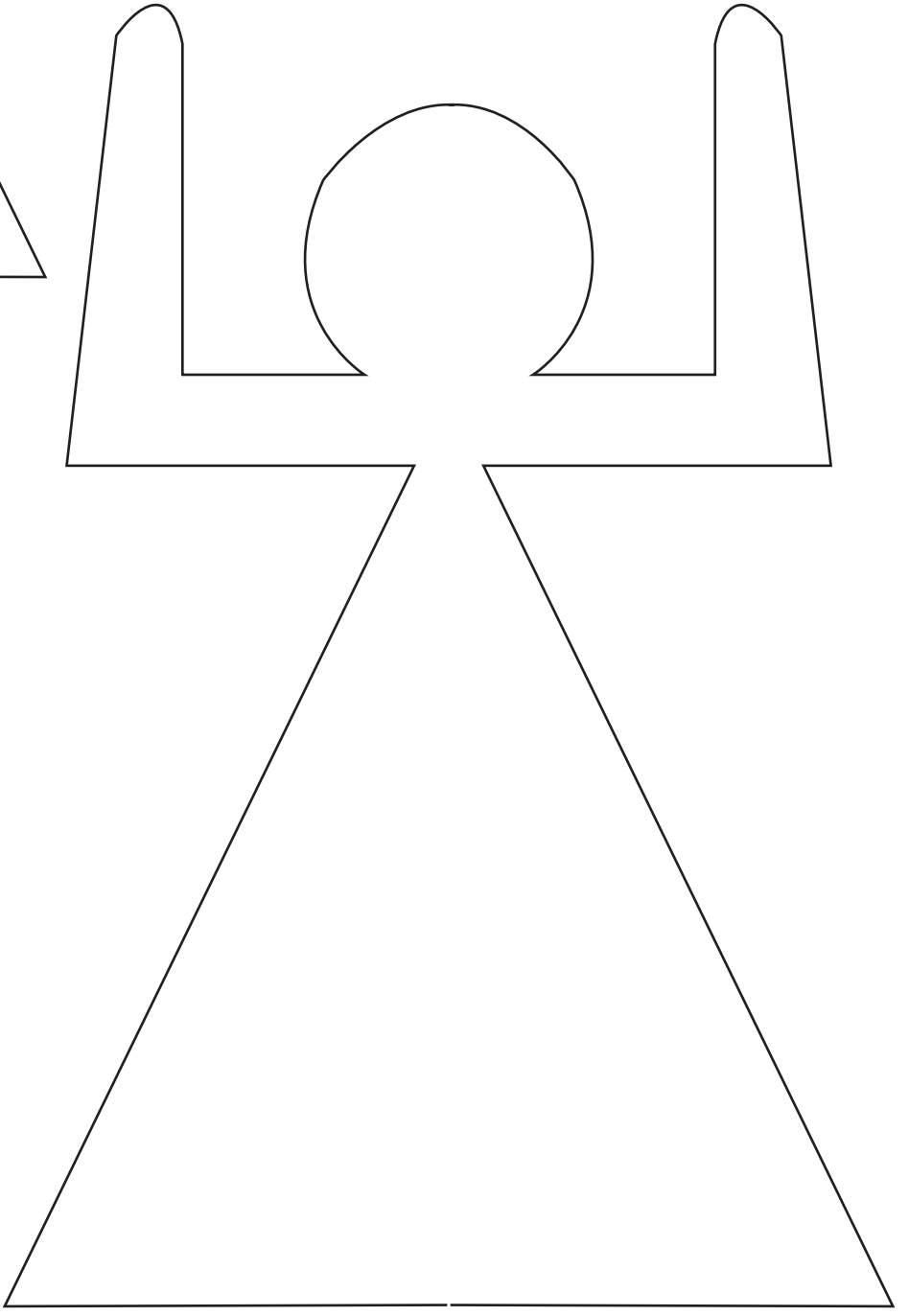
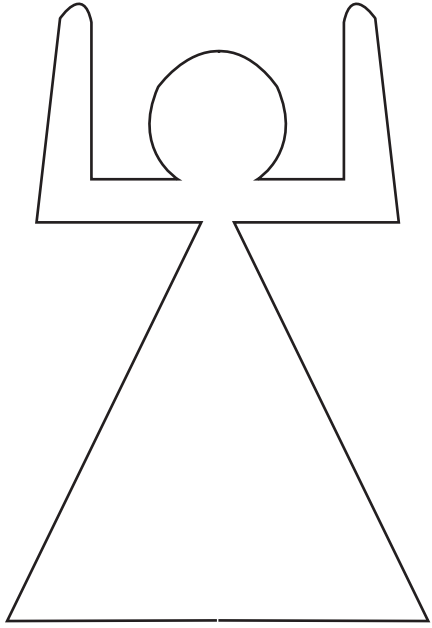

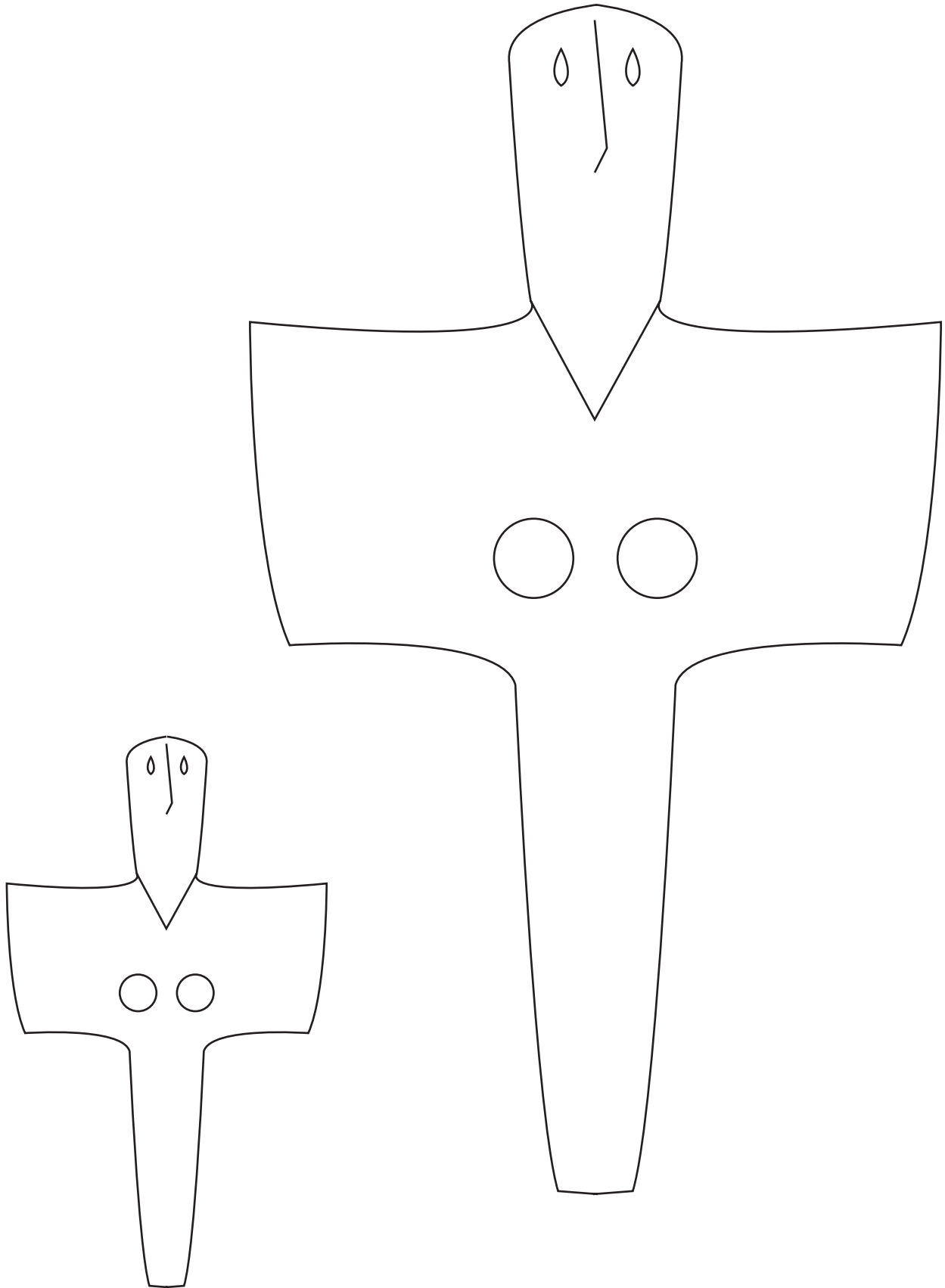

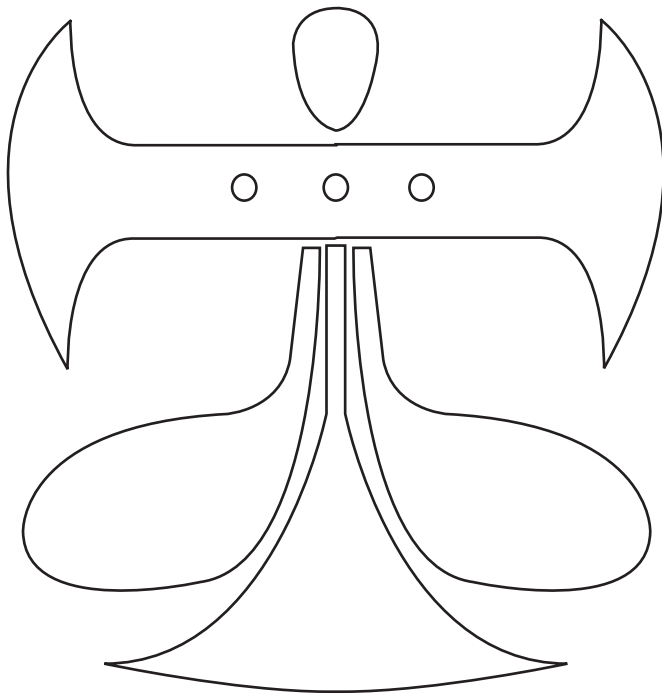

This Butterfly Goddess renders Herself beautifully in leather work.

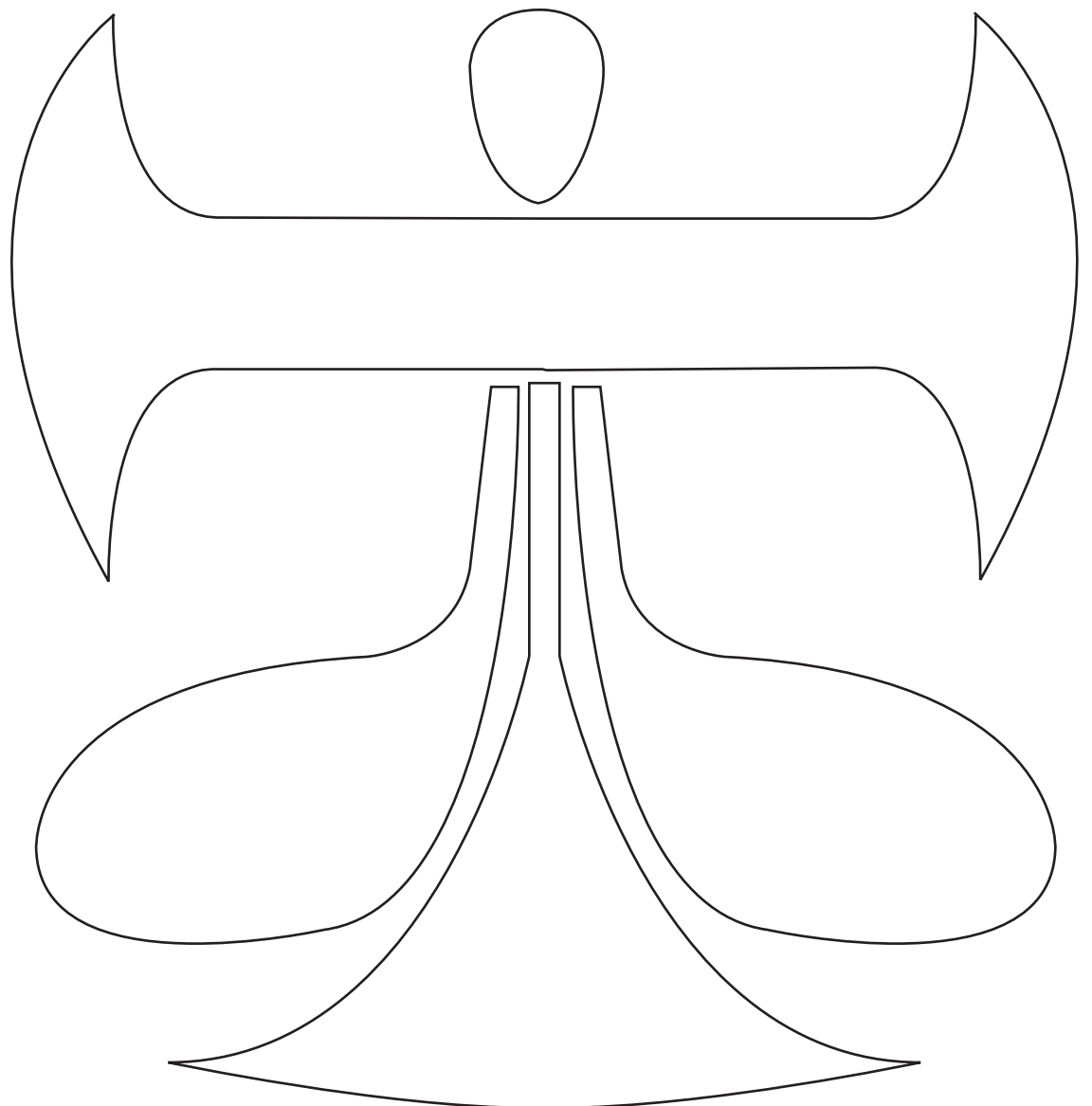

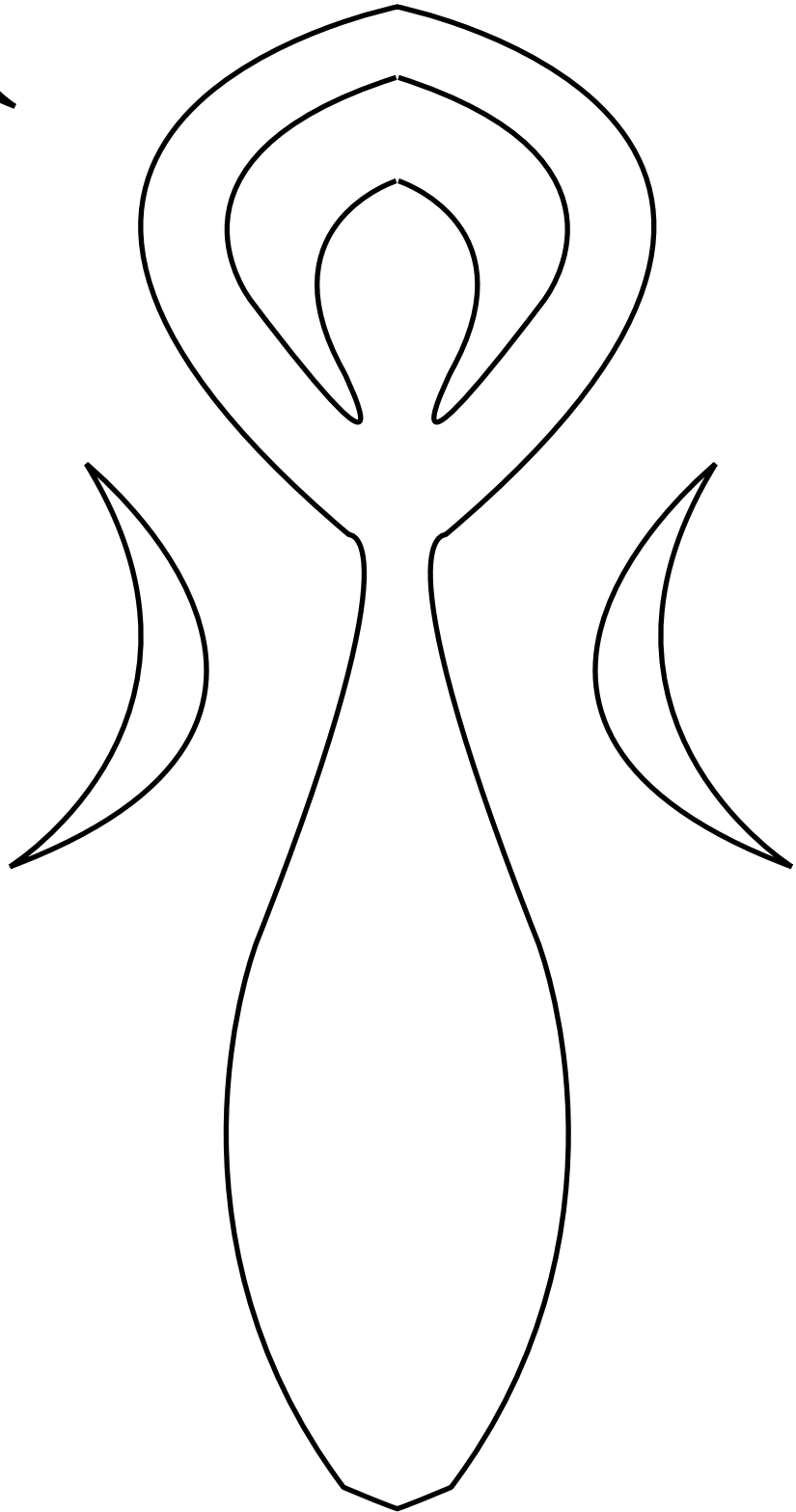
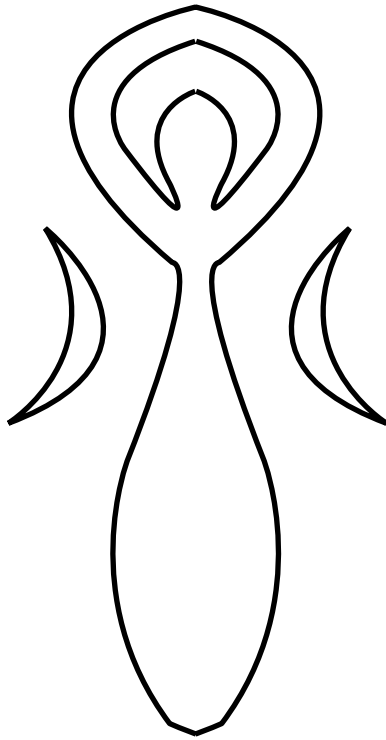

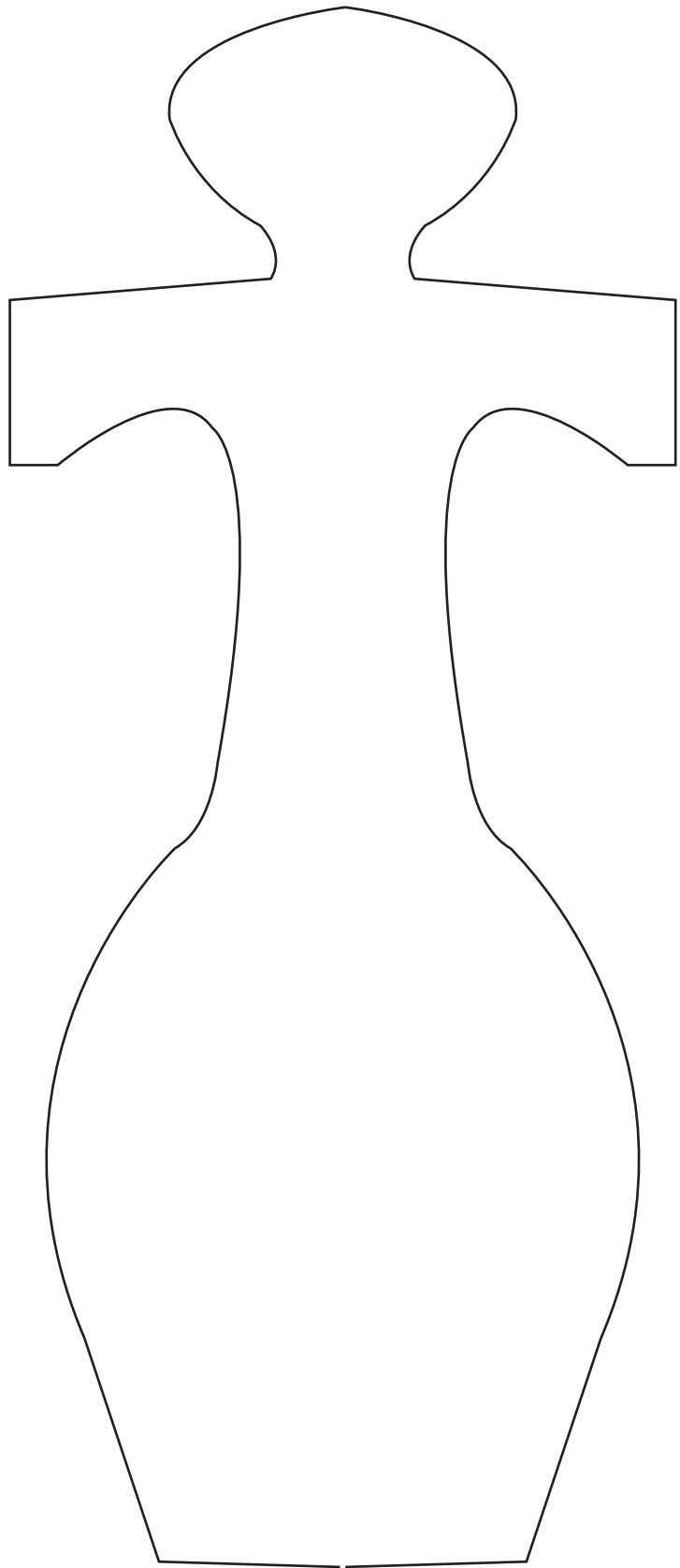
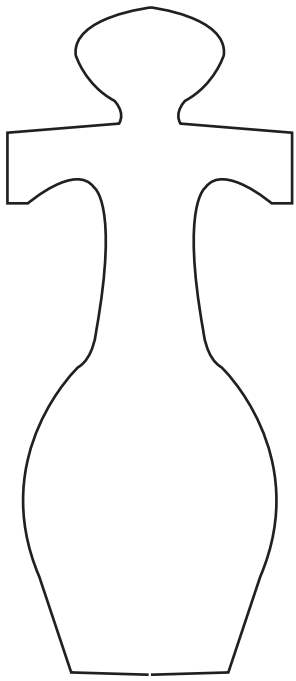

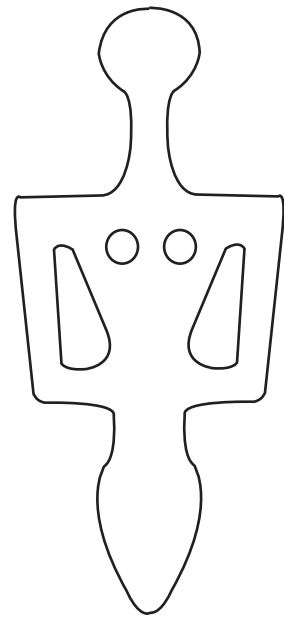
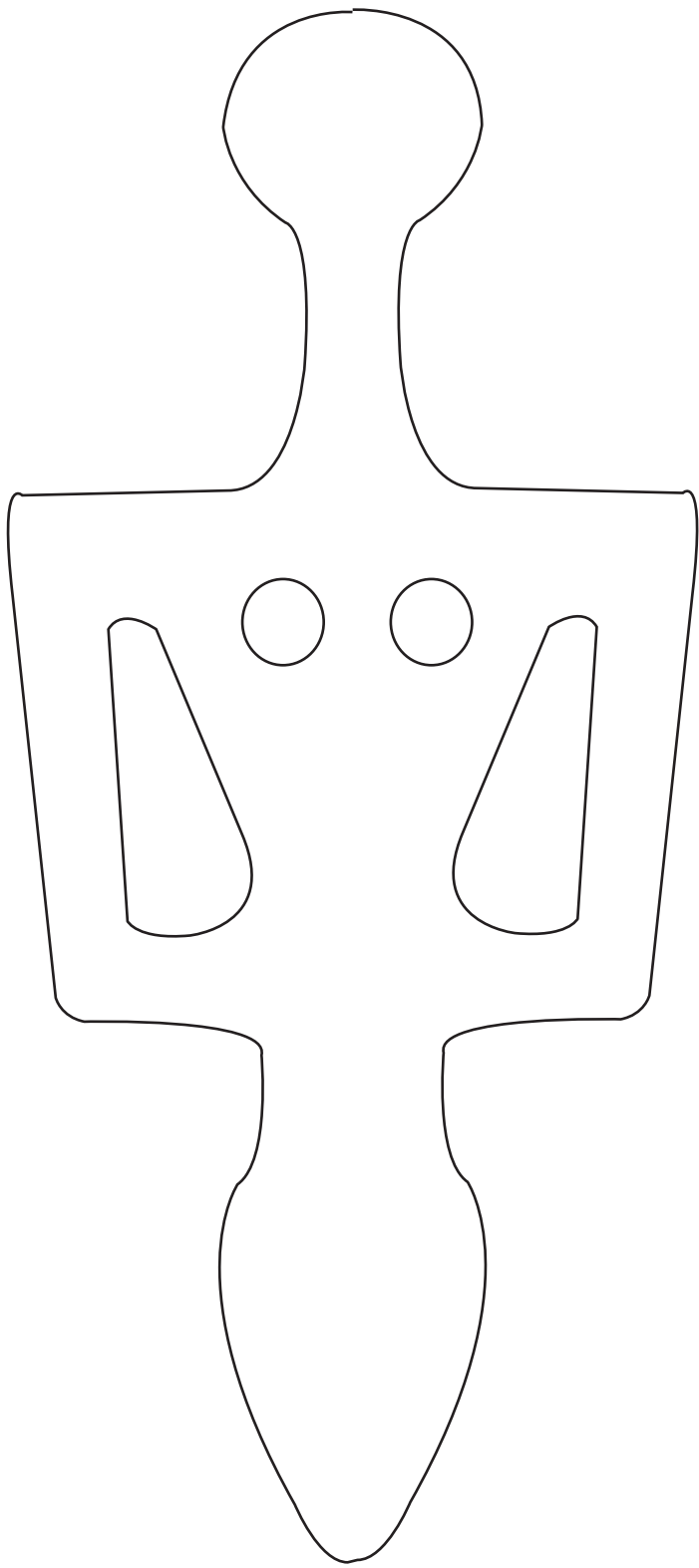

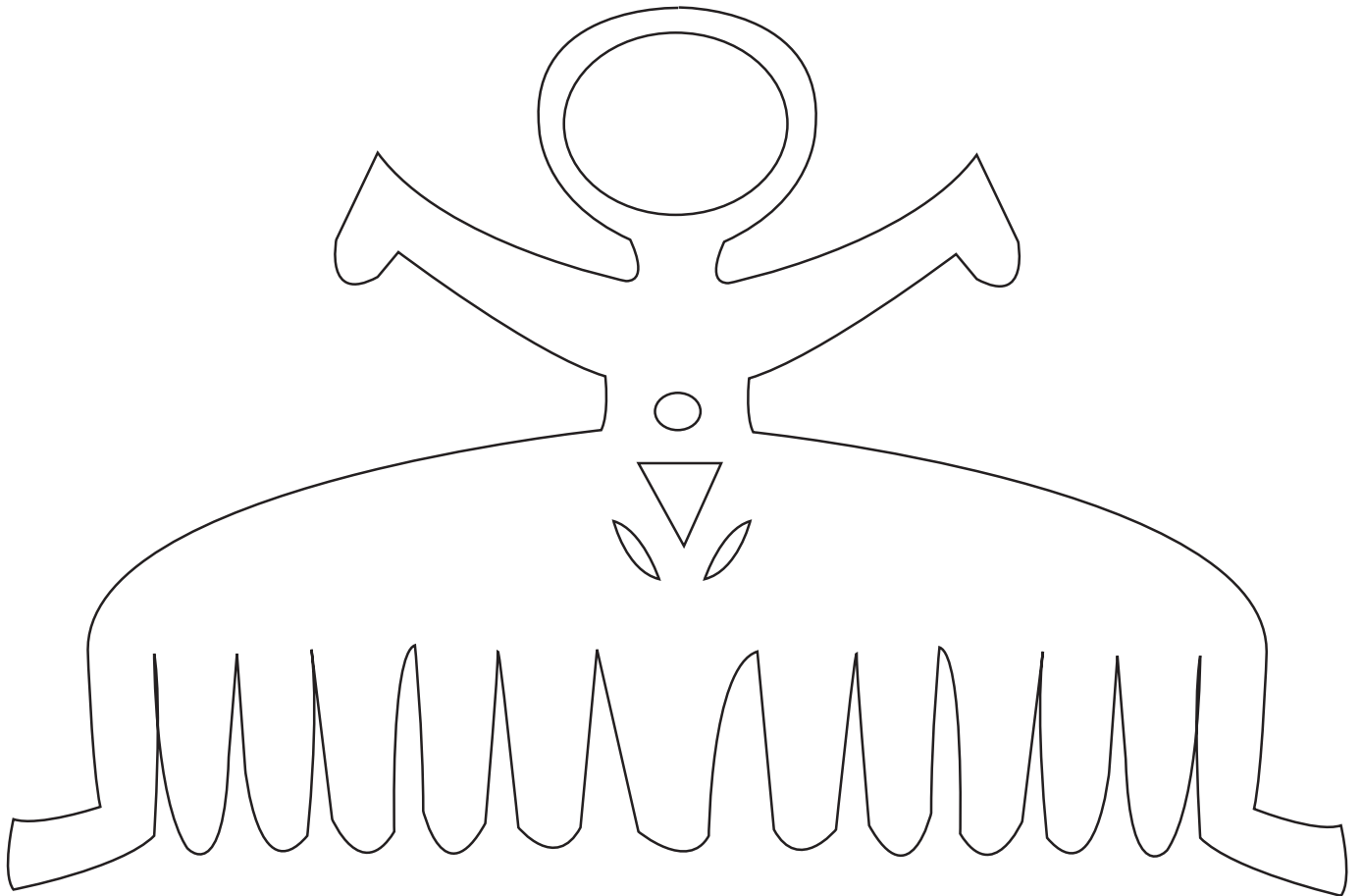
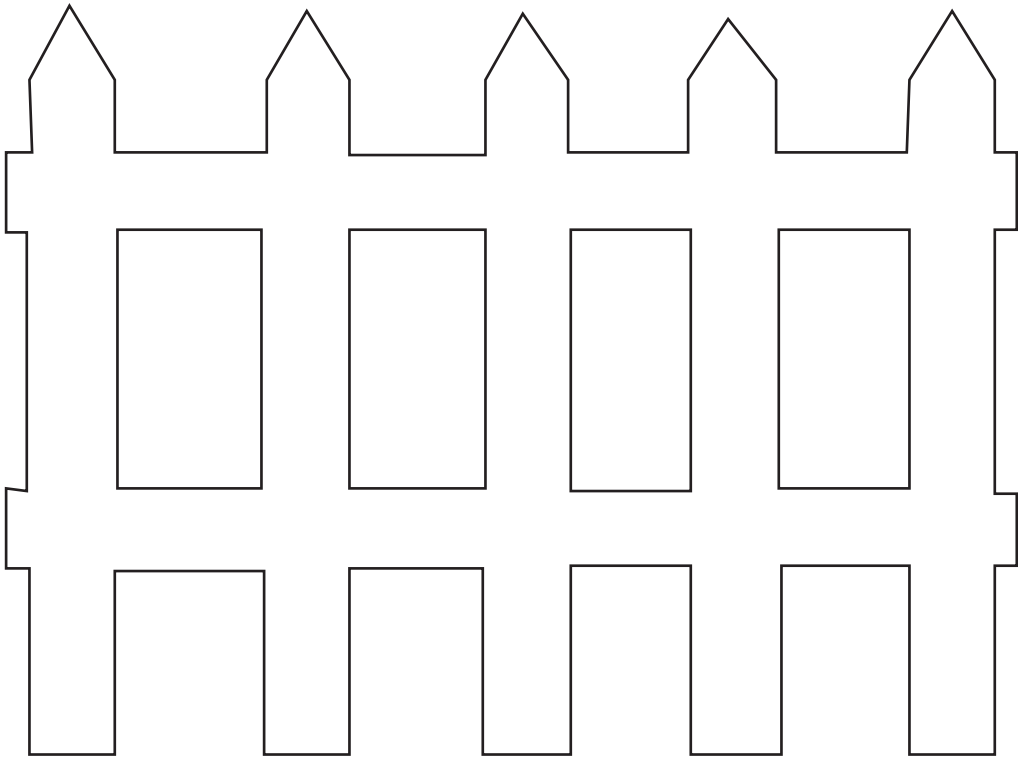

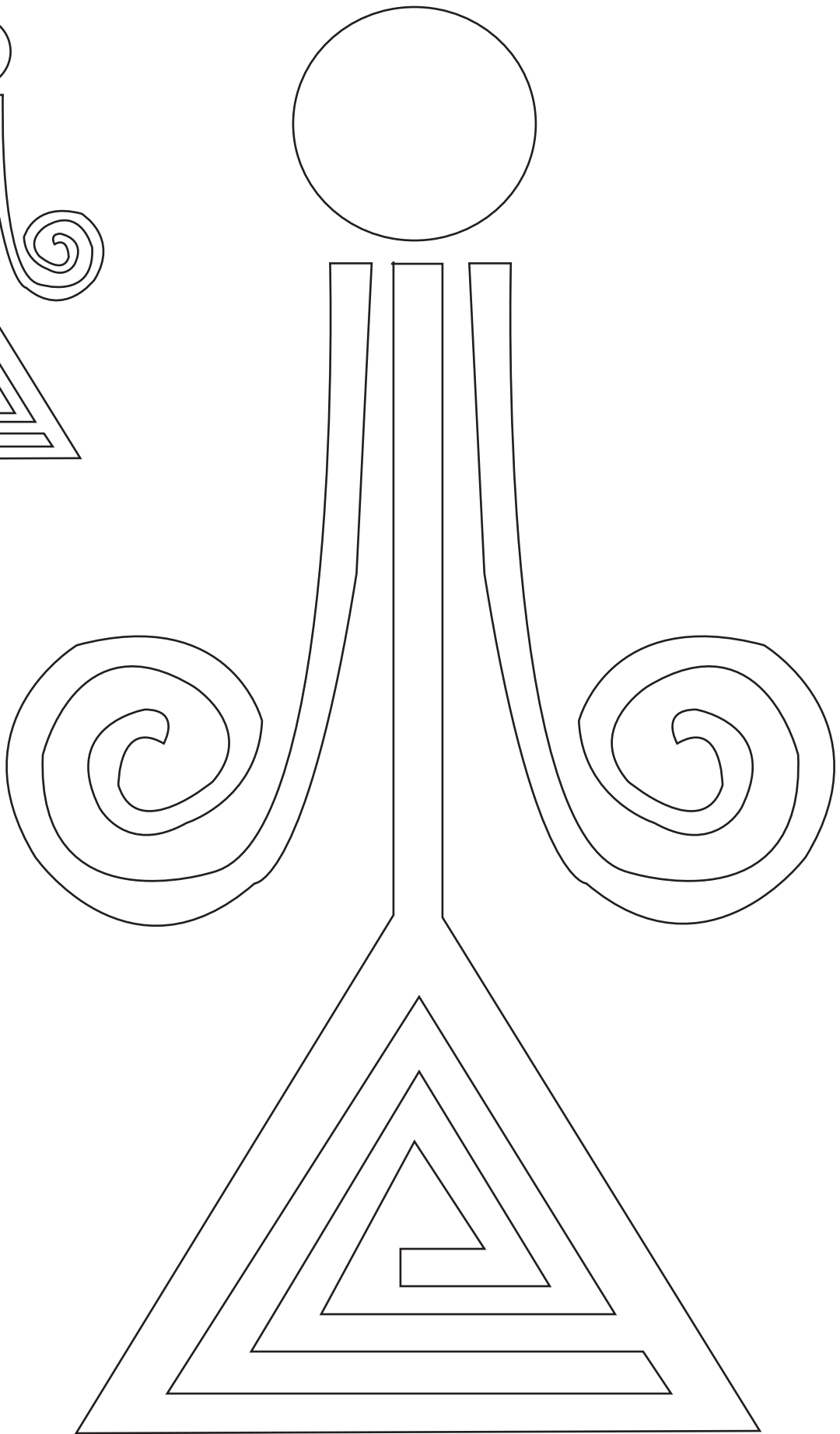
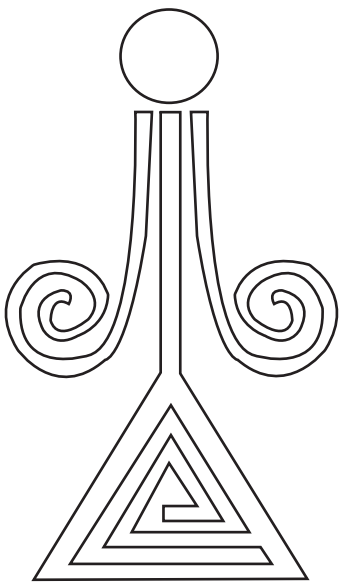

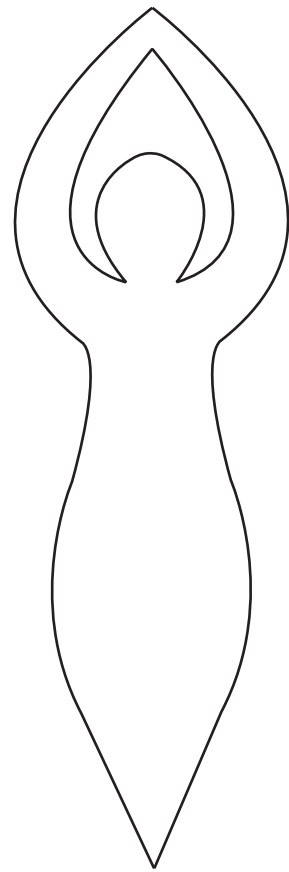
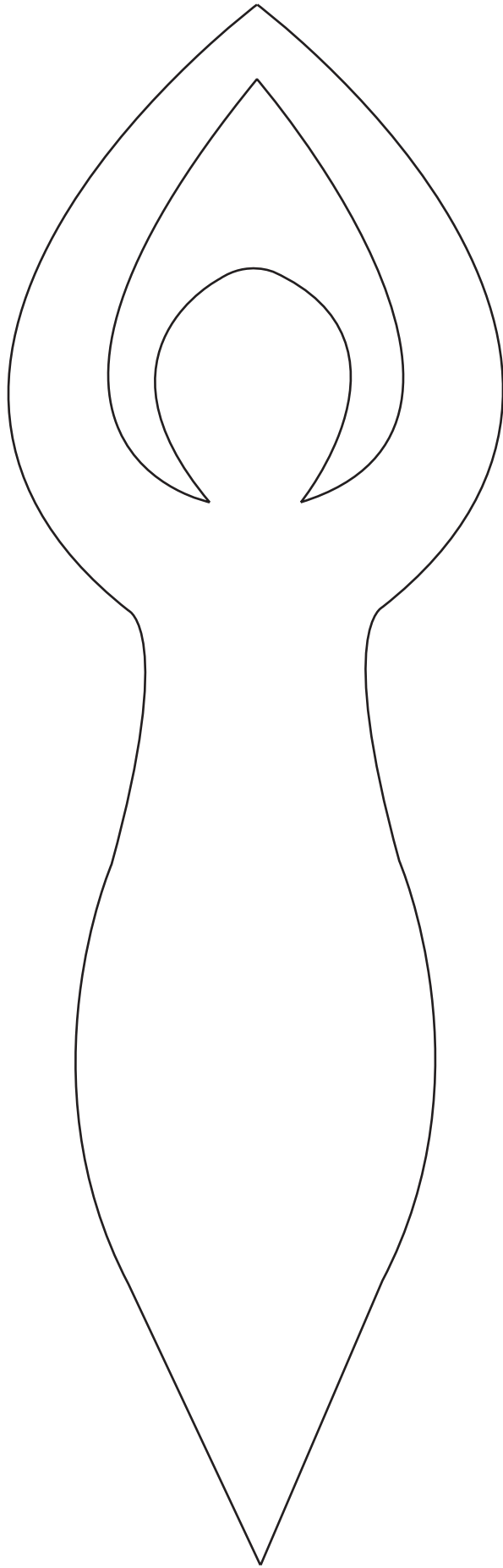

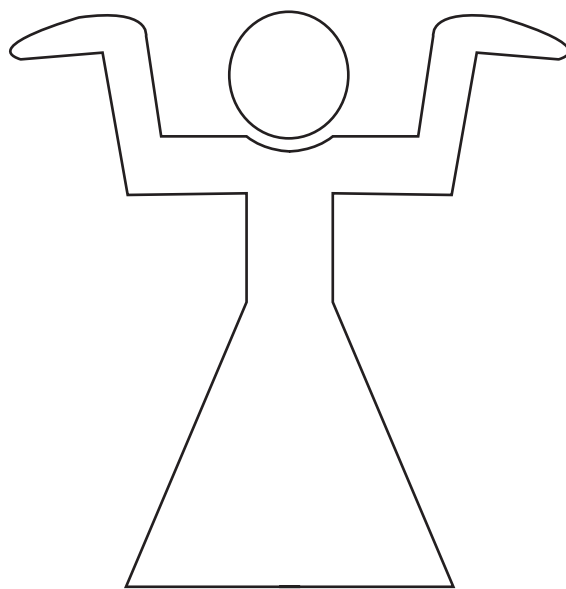
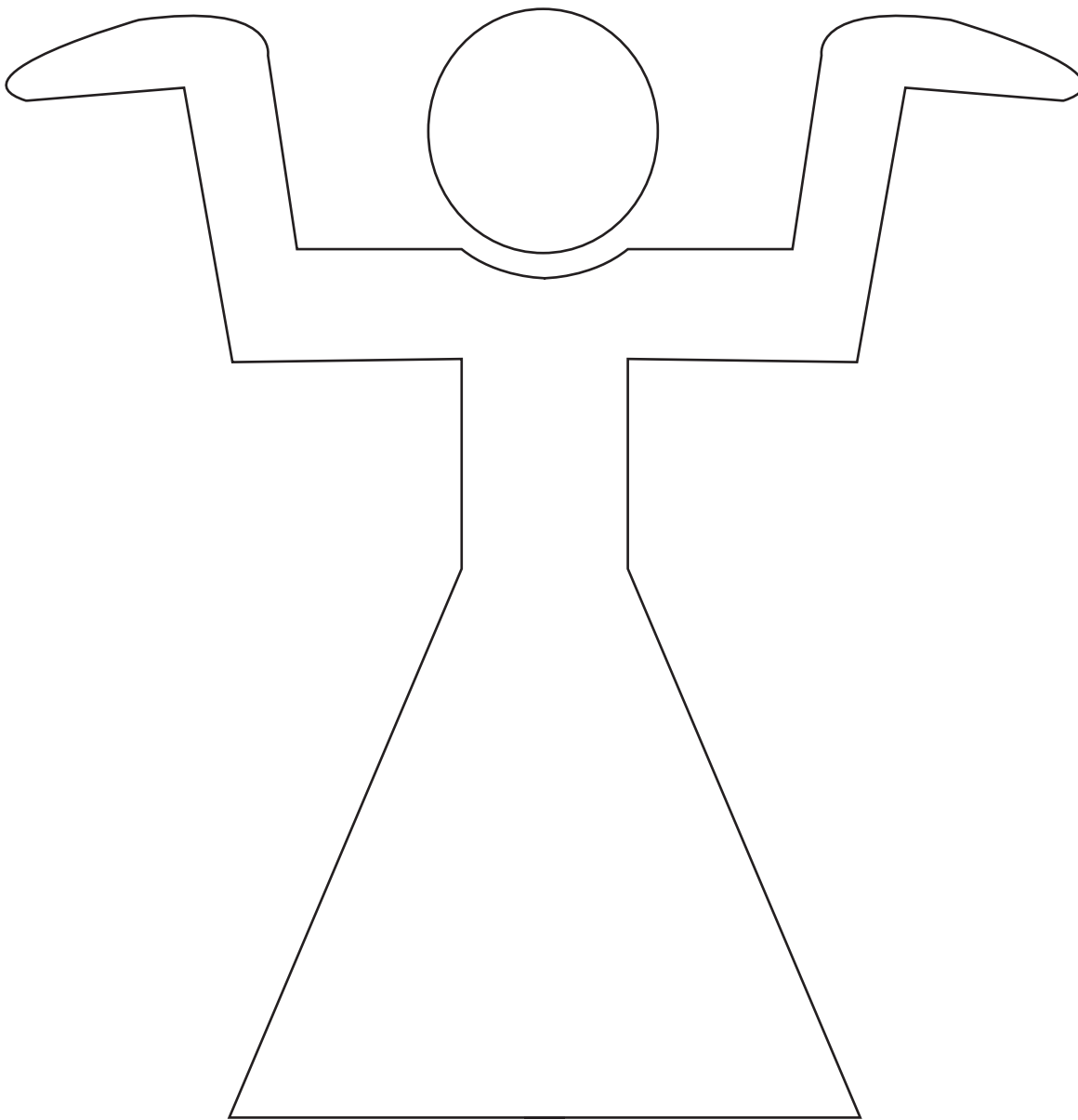

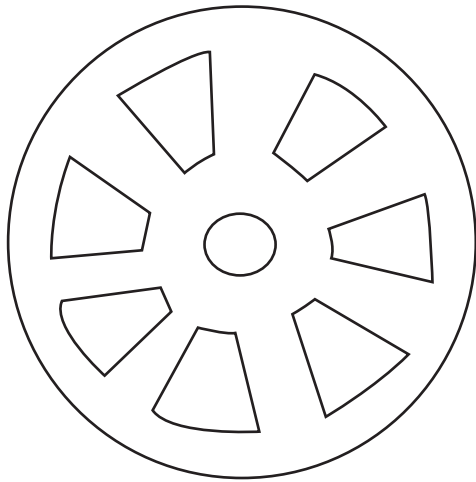
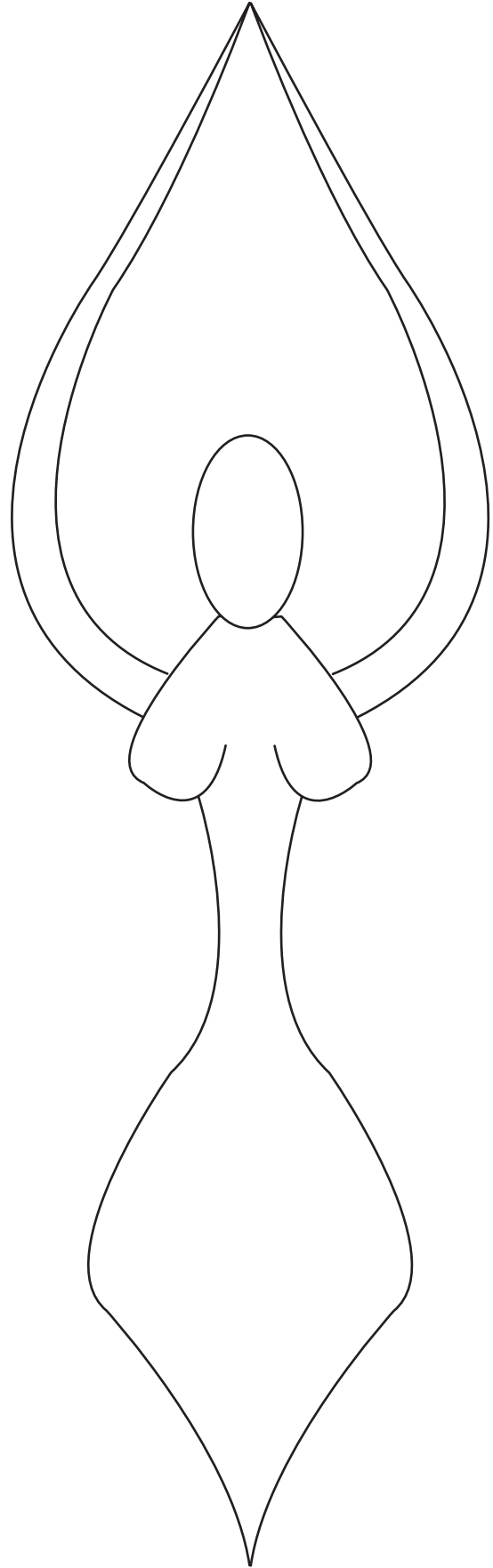
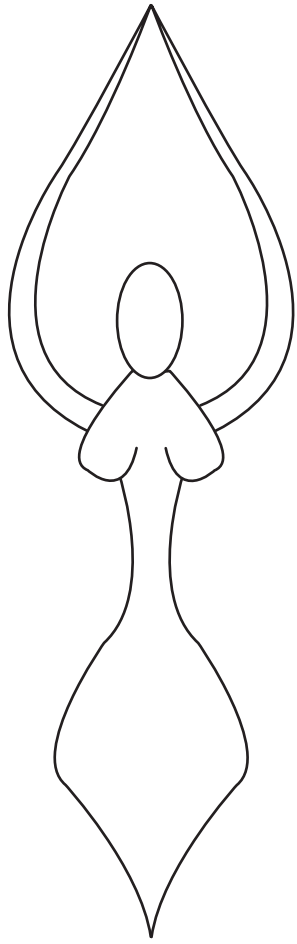

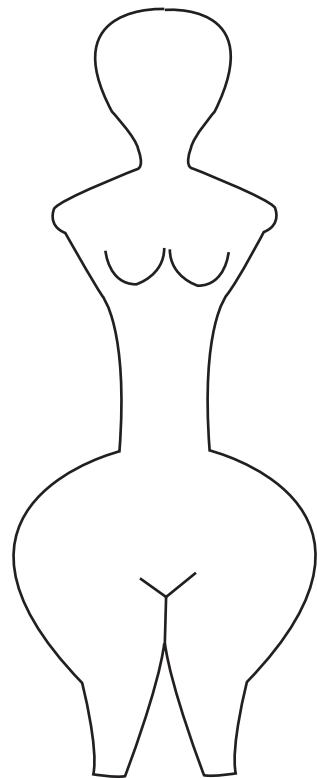
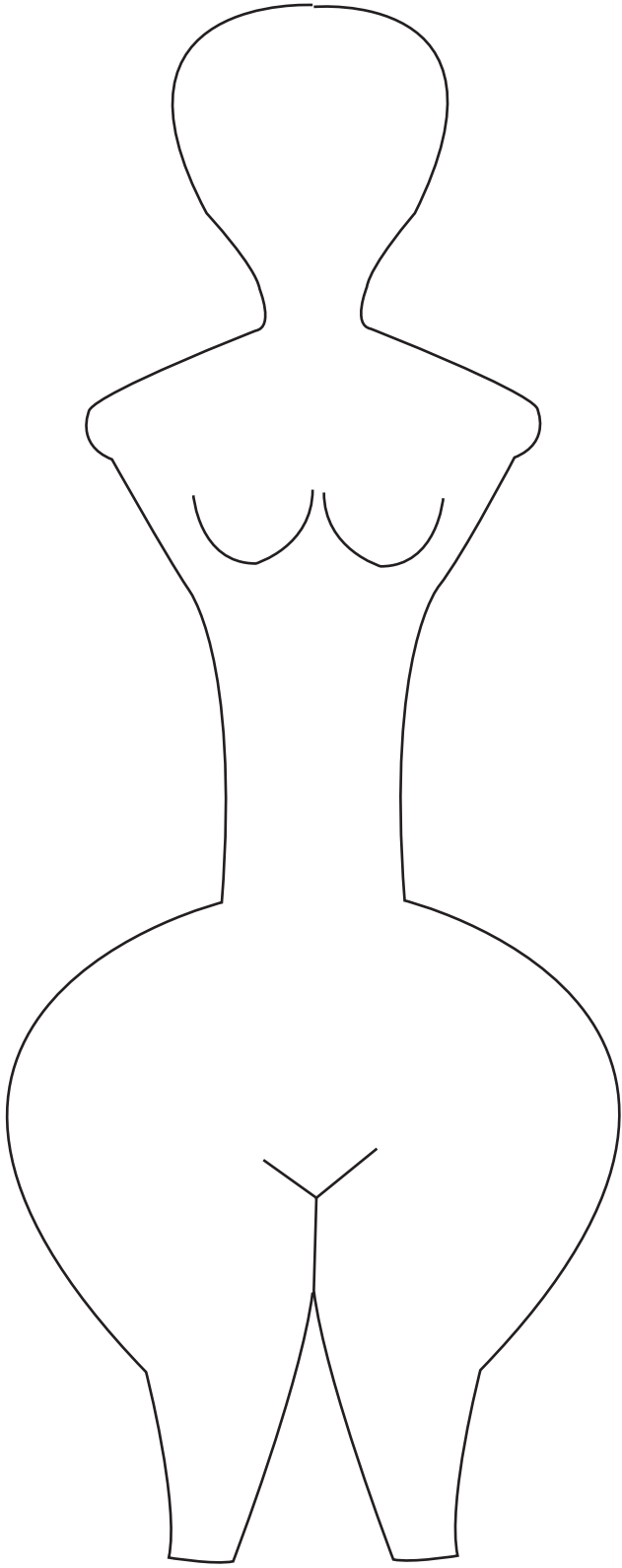

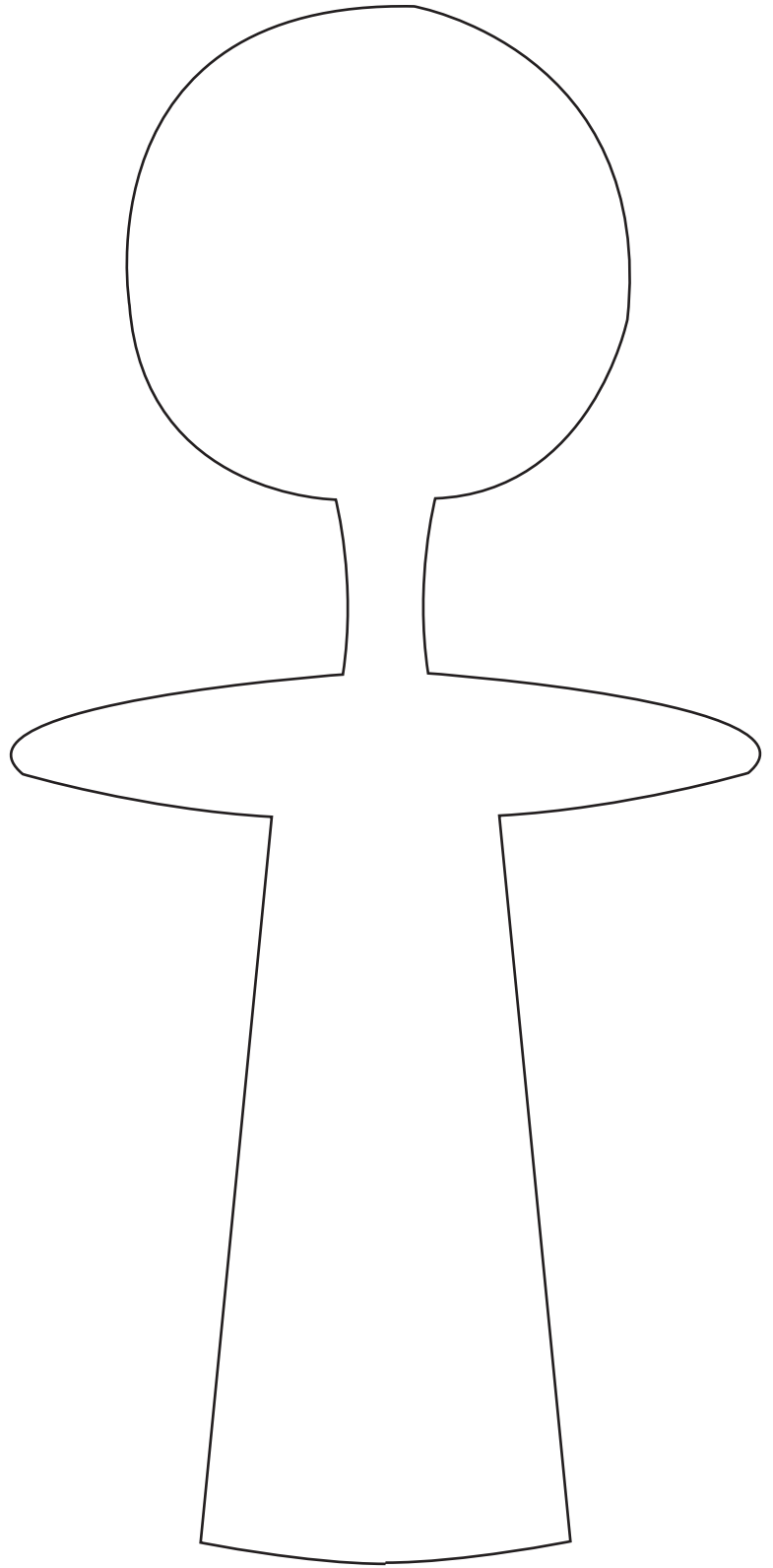
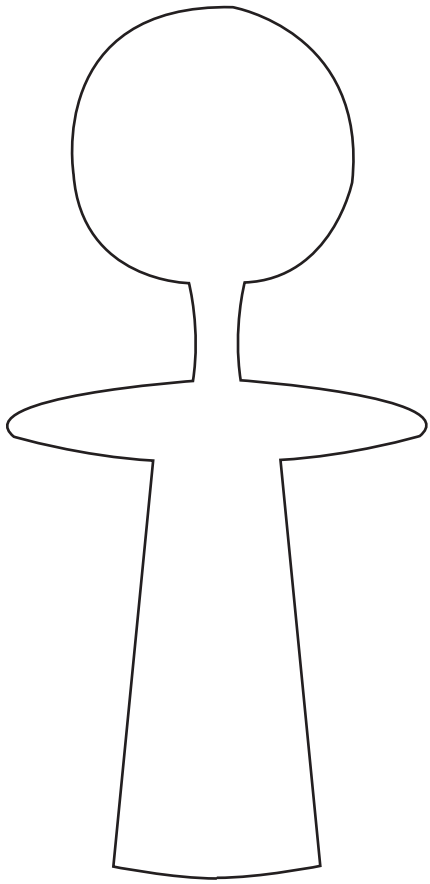

These patterns can easily be rendered 3D by cutting them out of wood or by molding them from clay.

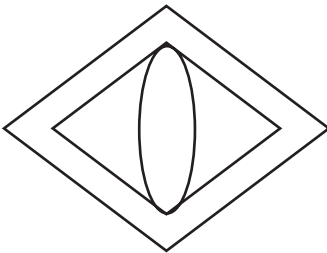
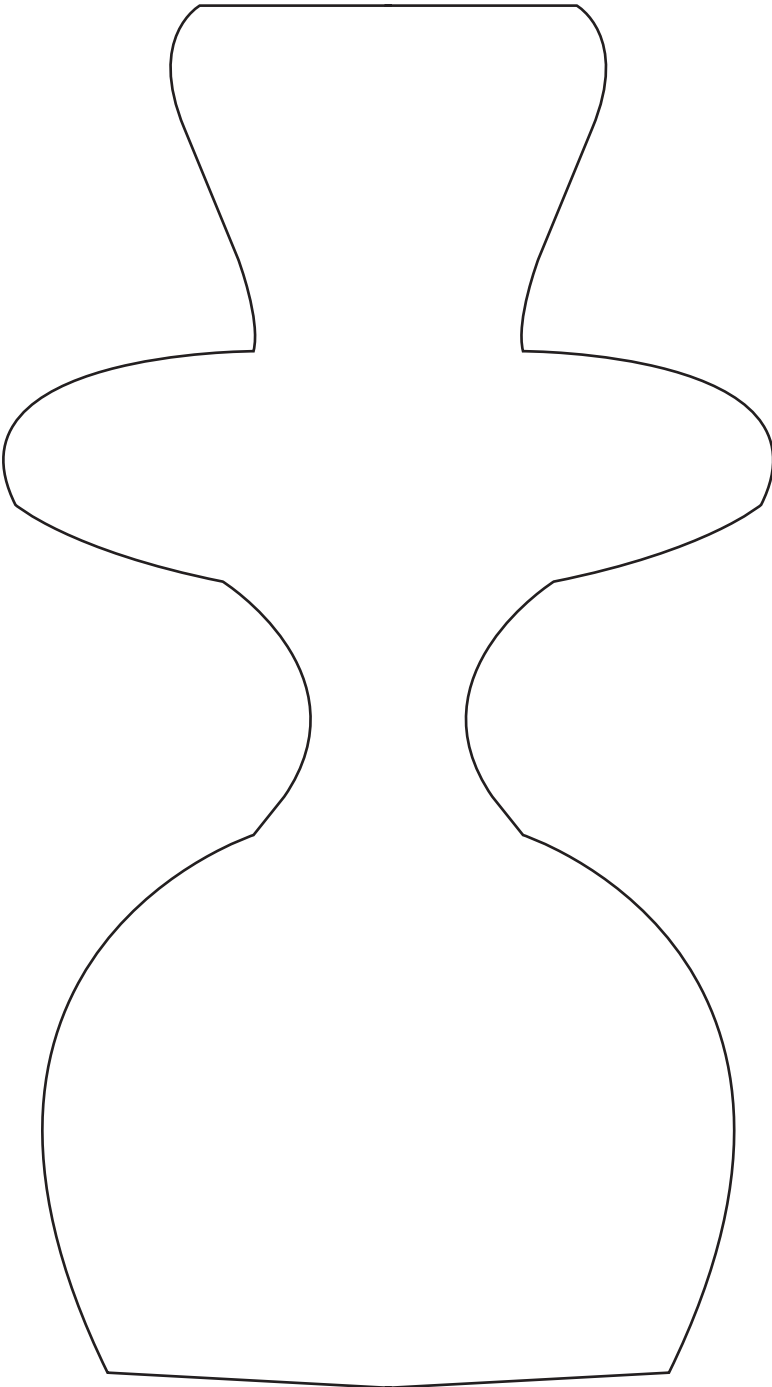
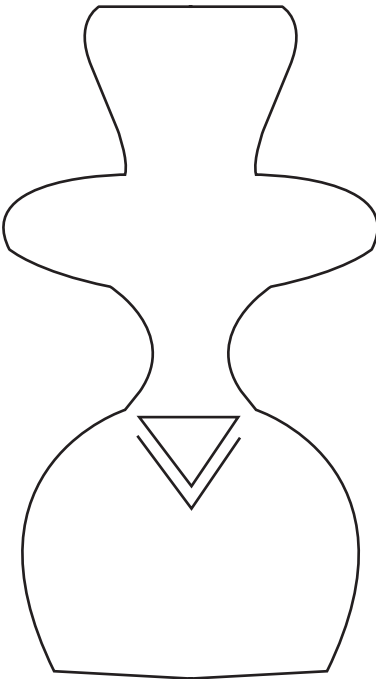

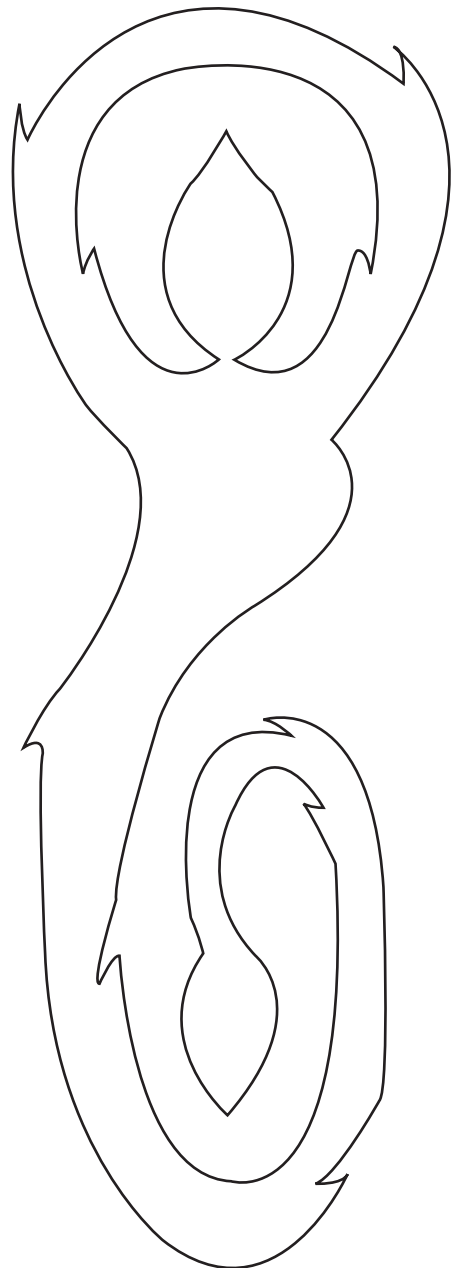
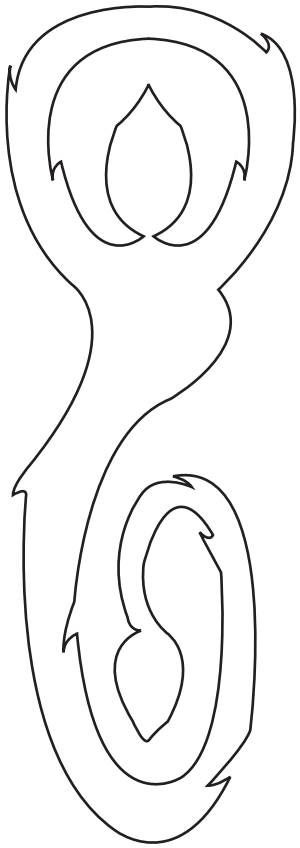

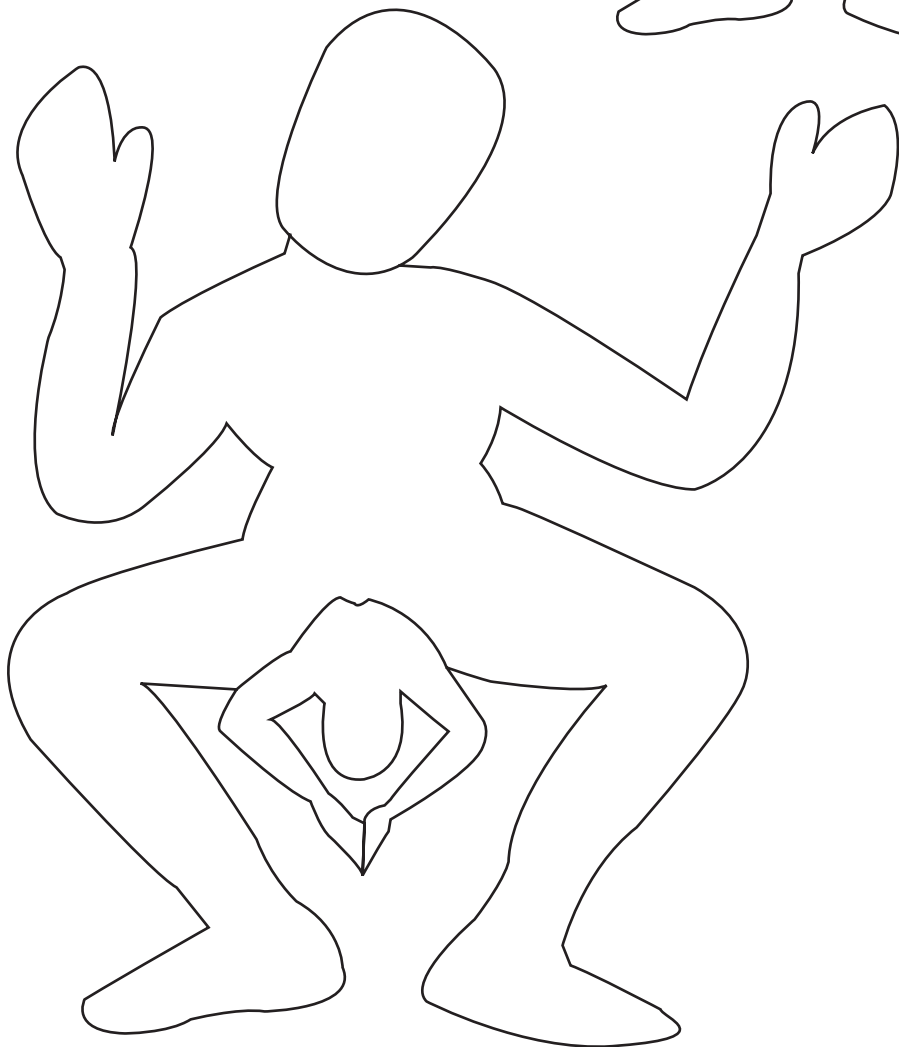
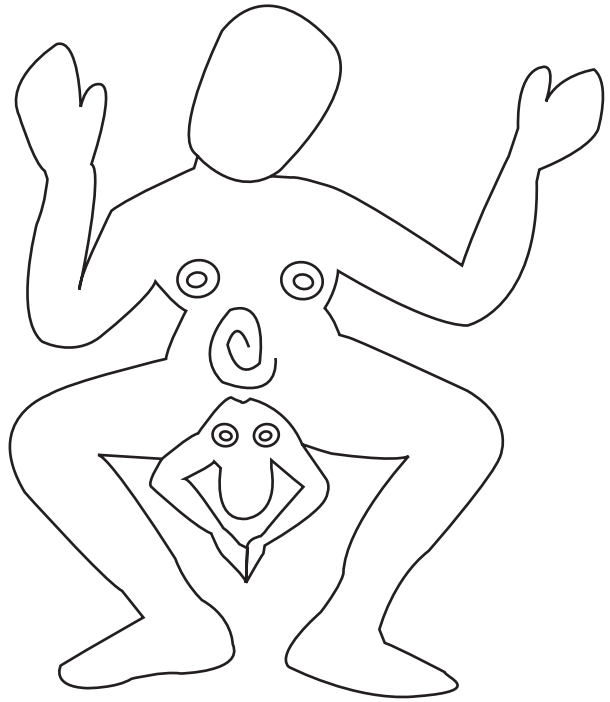



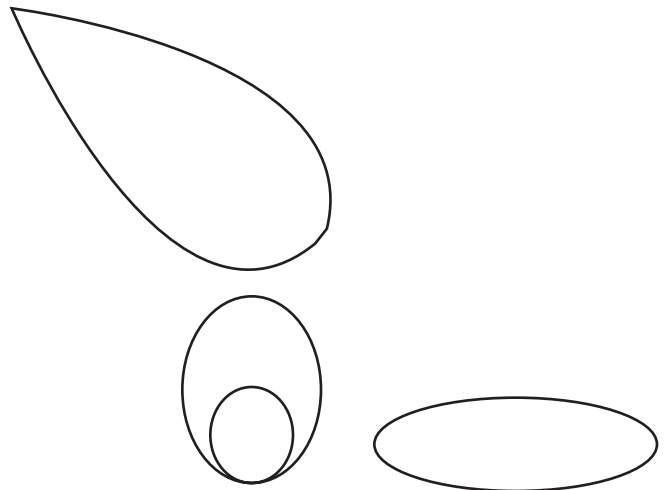
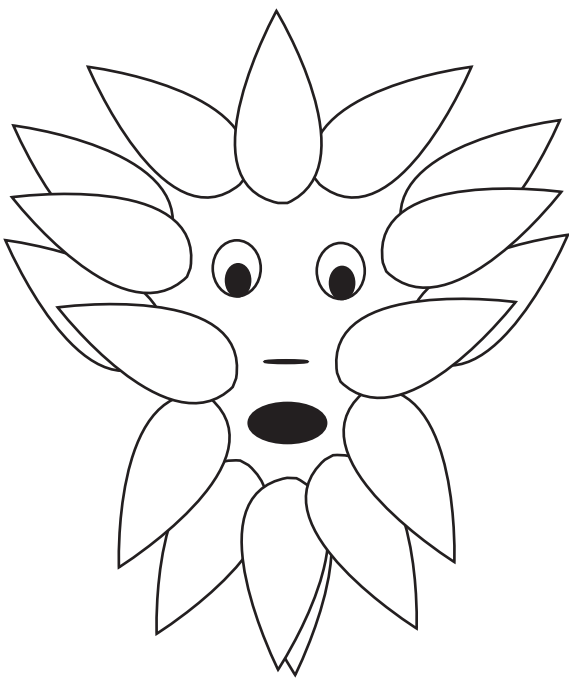
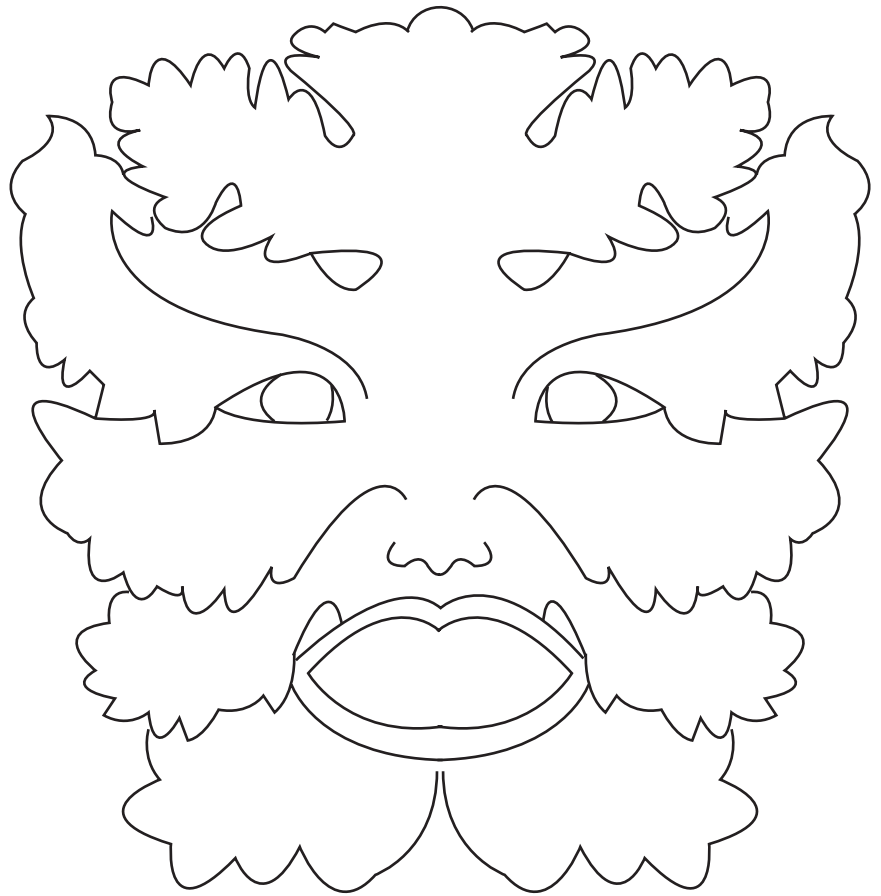





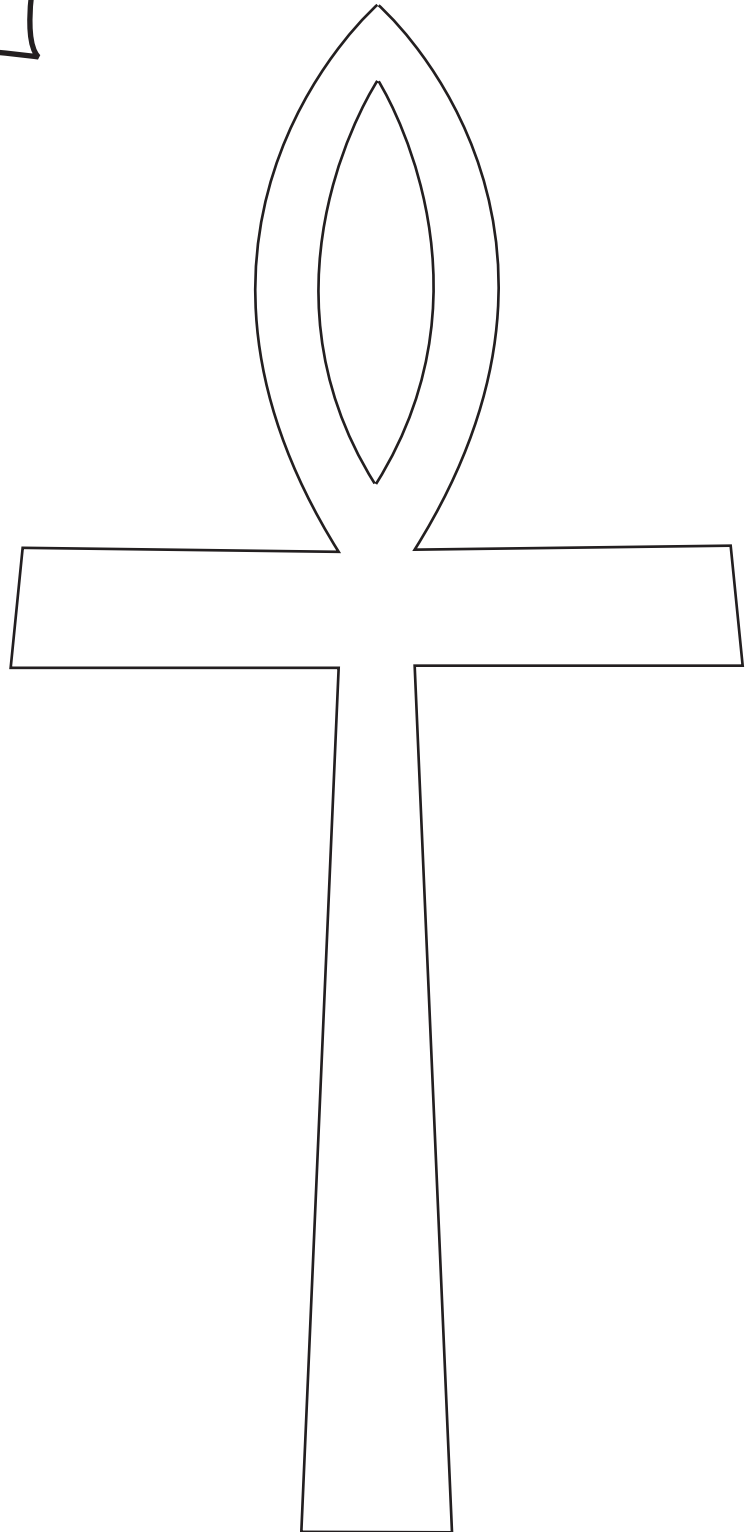
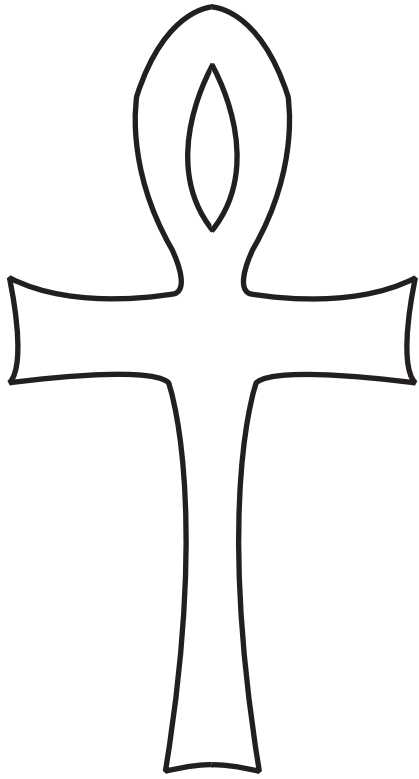

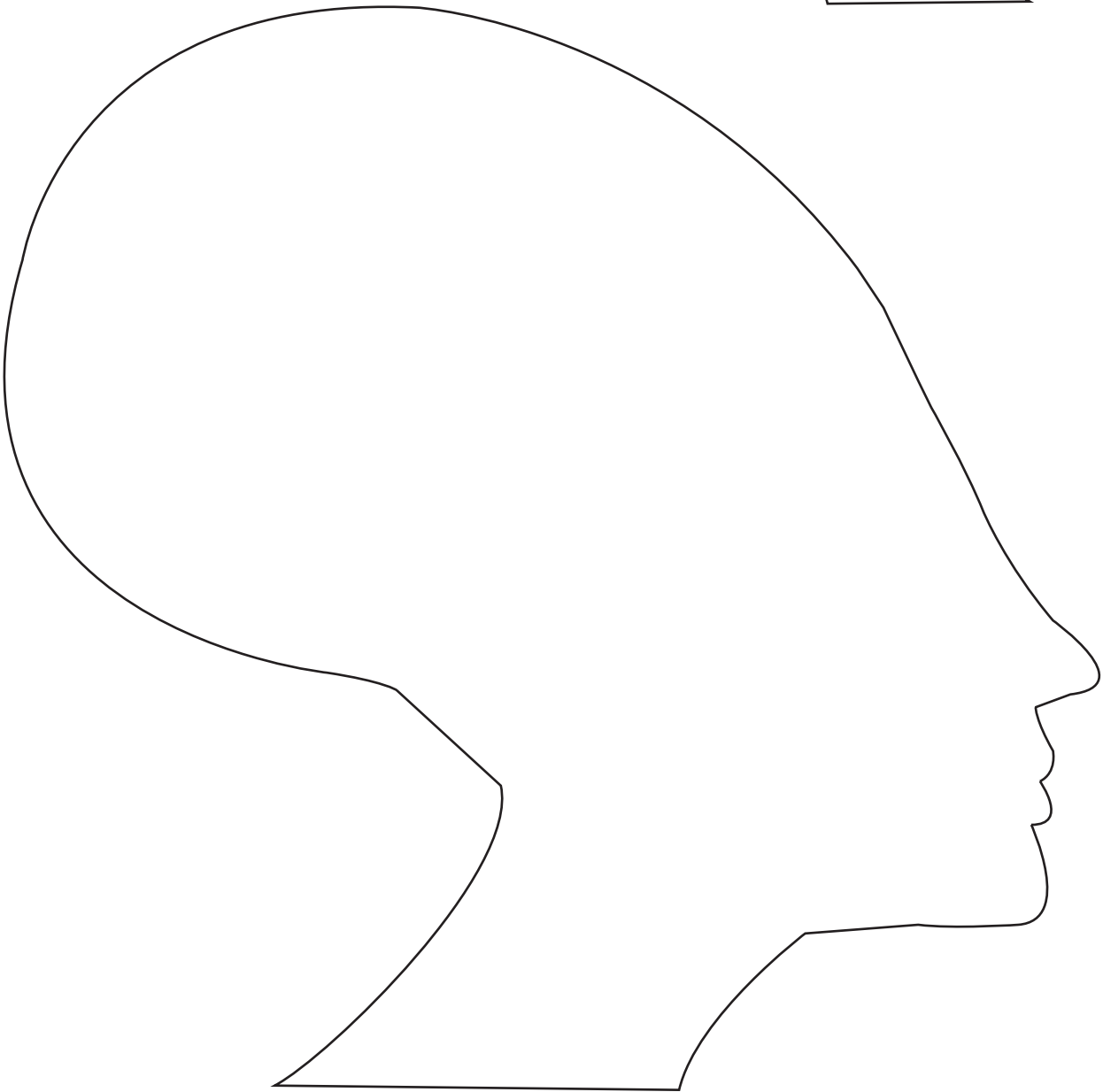

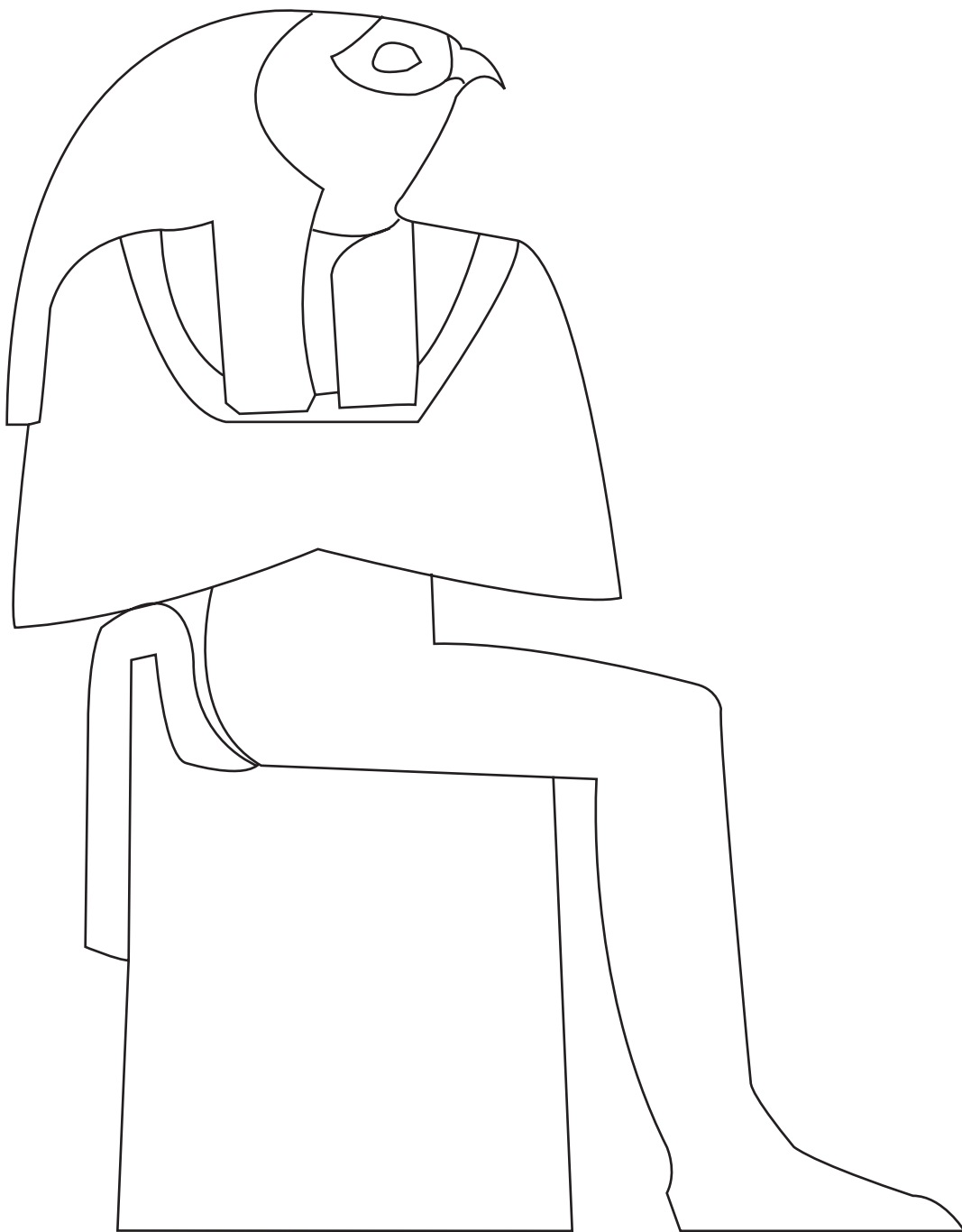
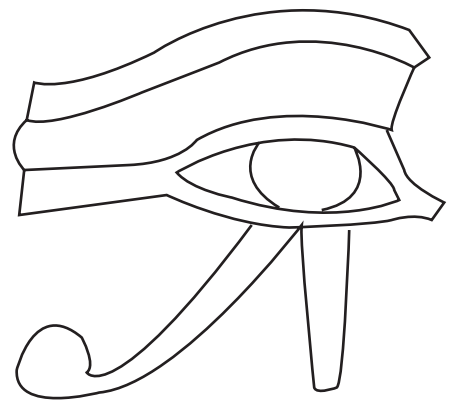

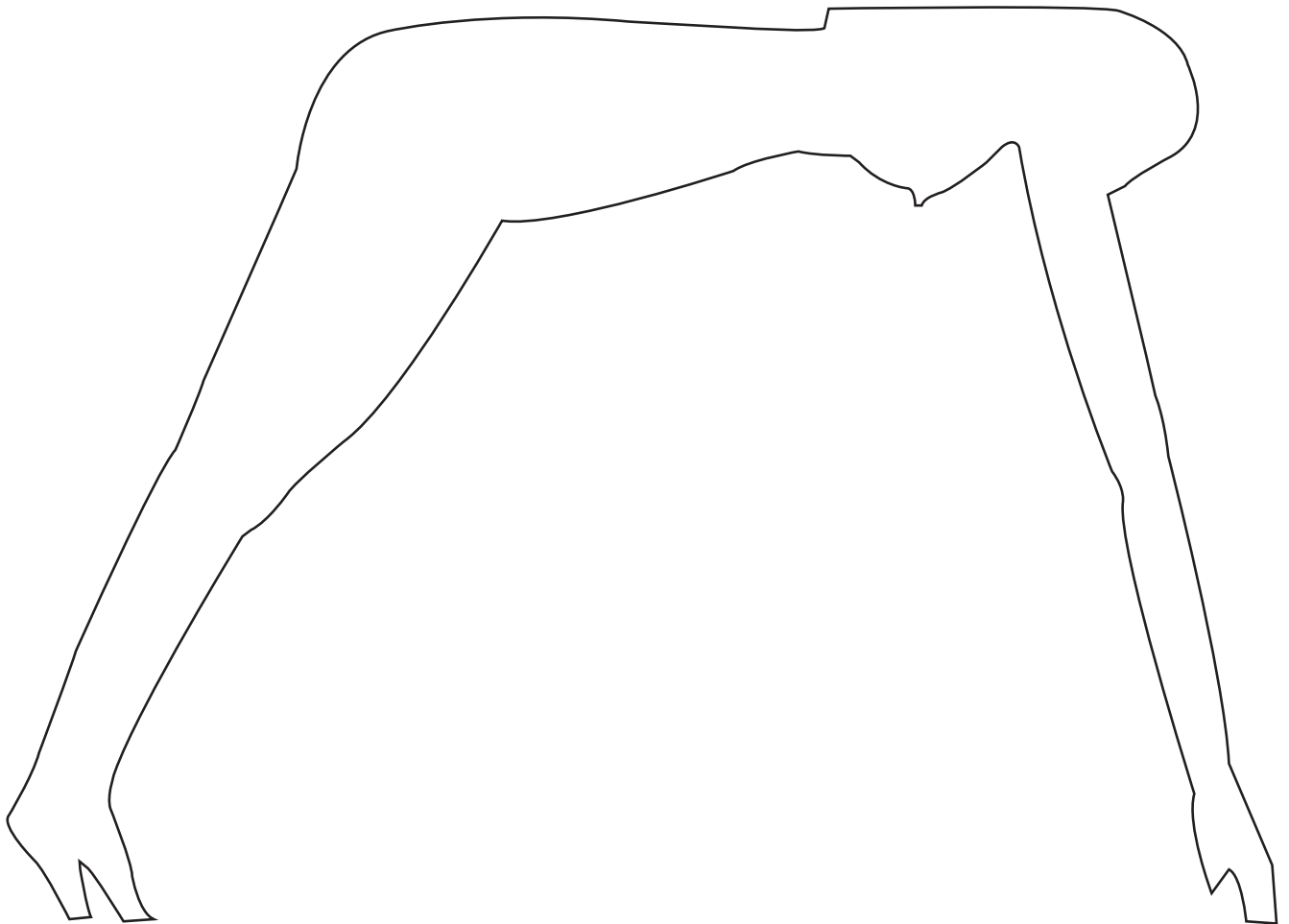
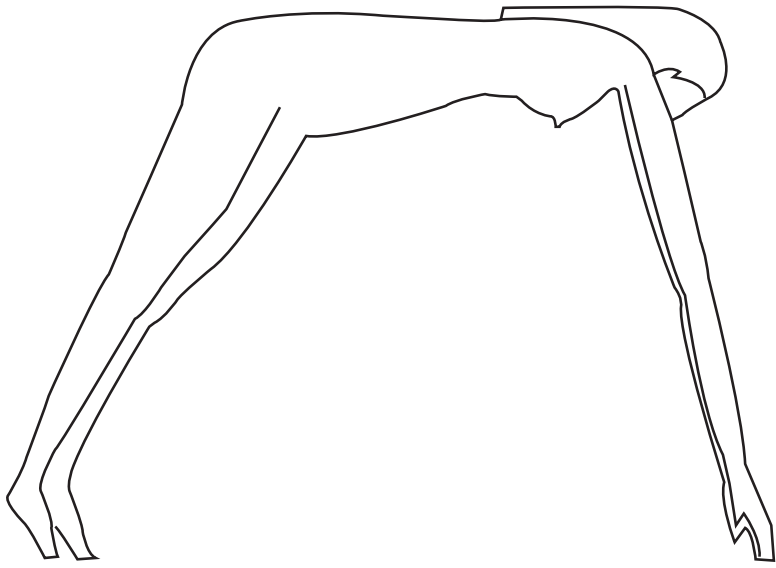

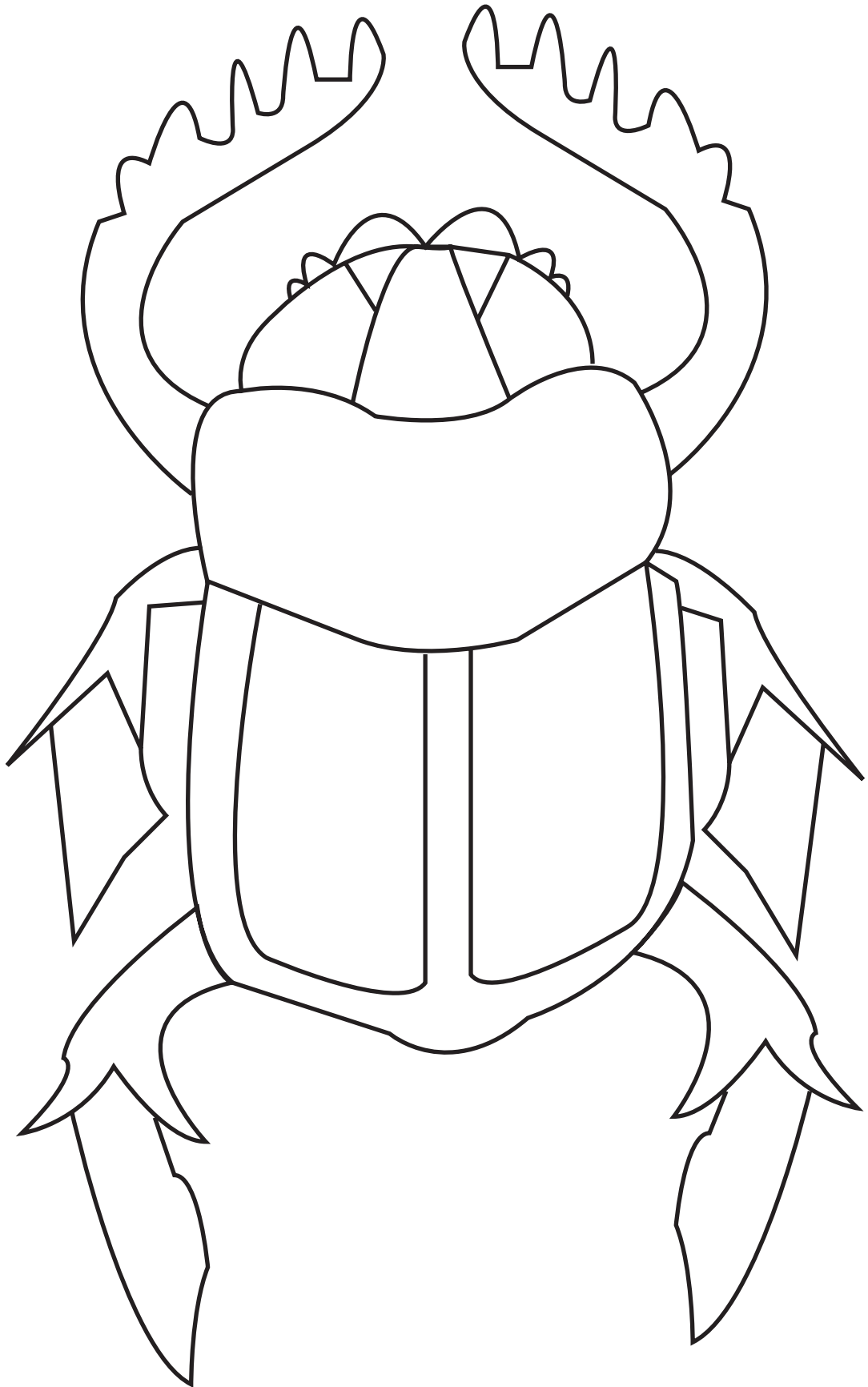

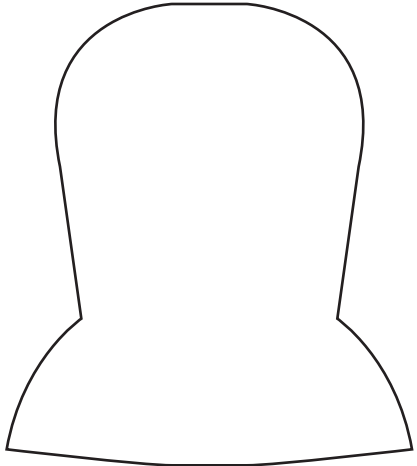
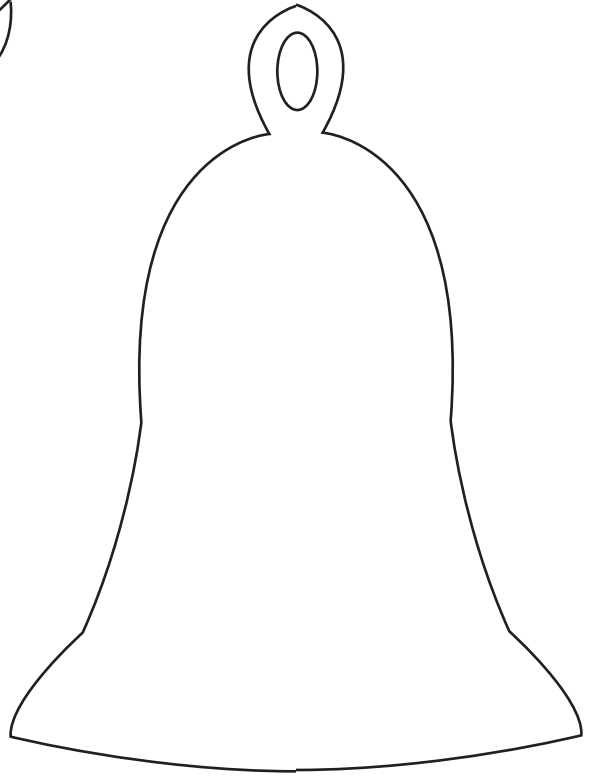
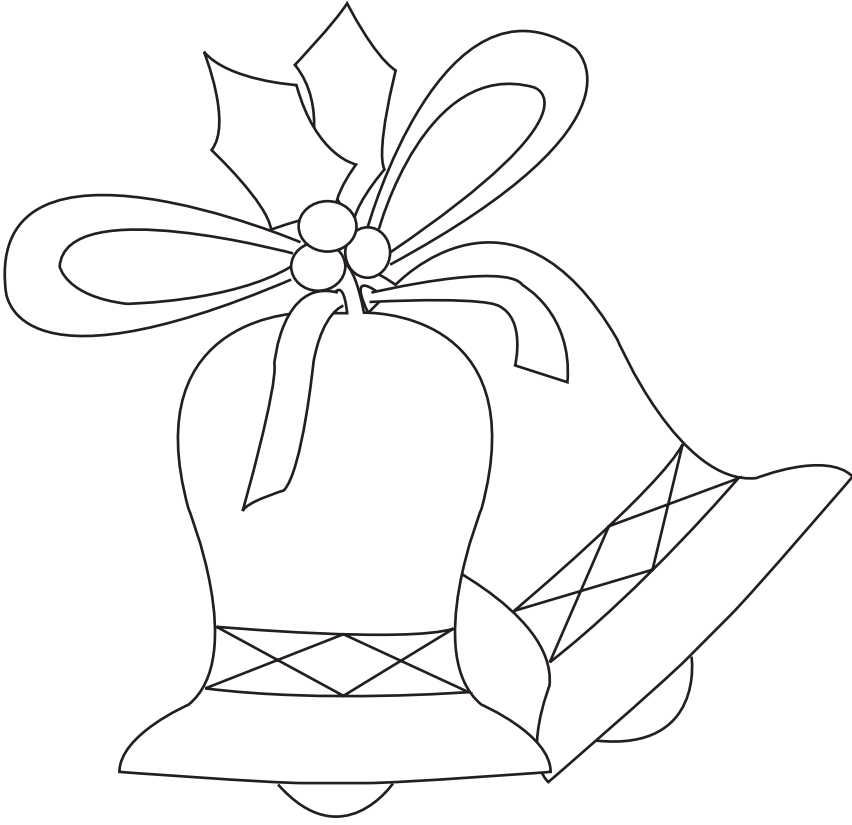

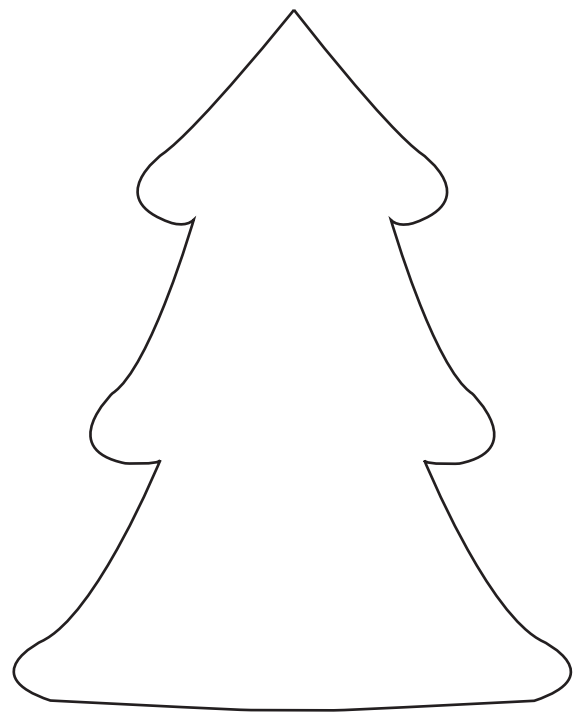
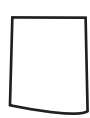
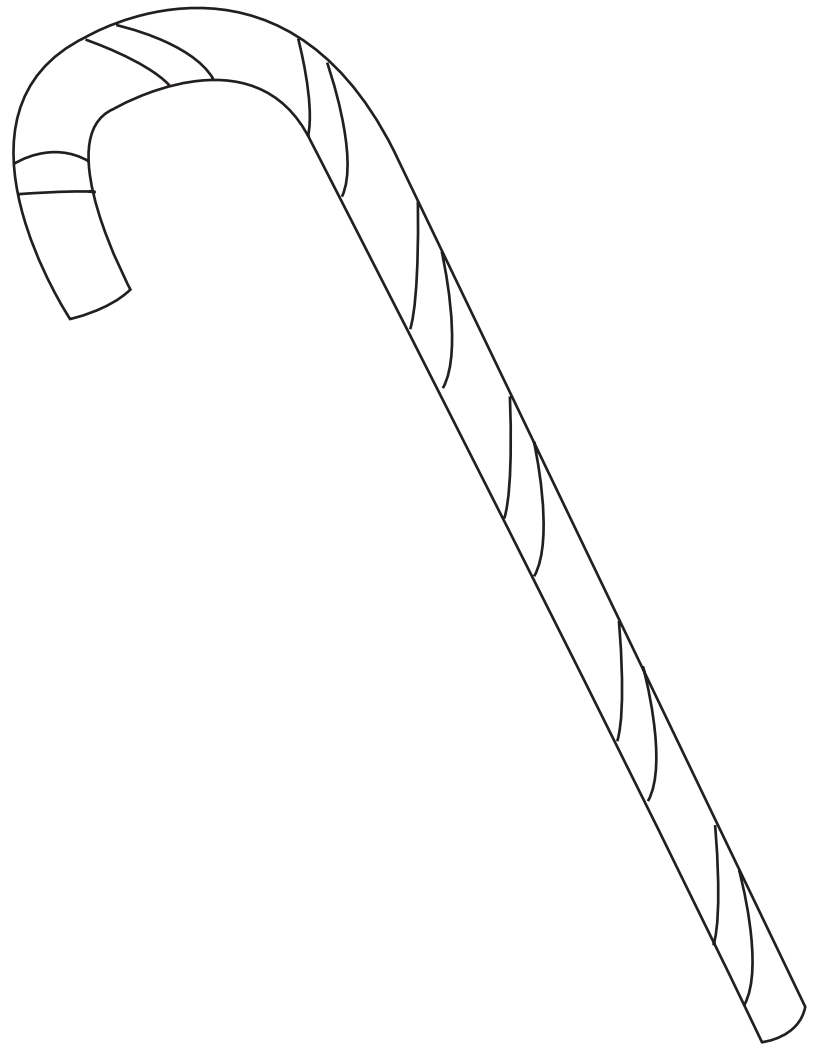
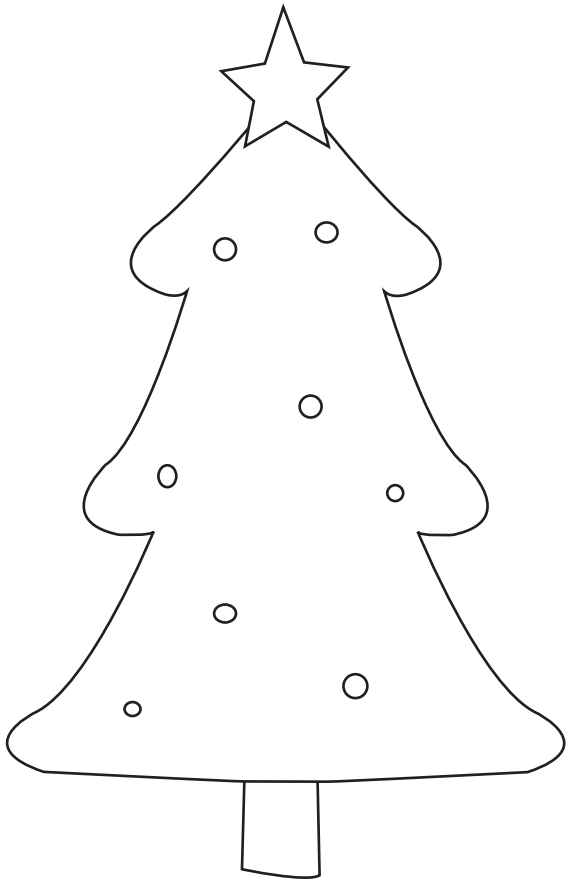

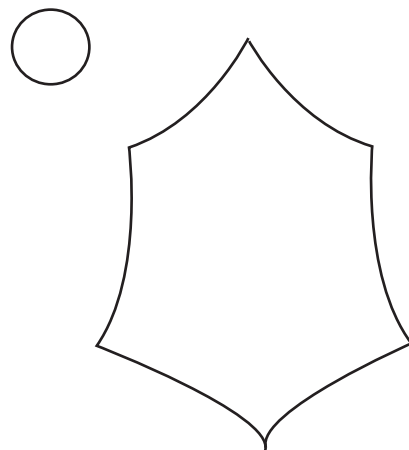
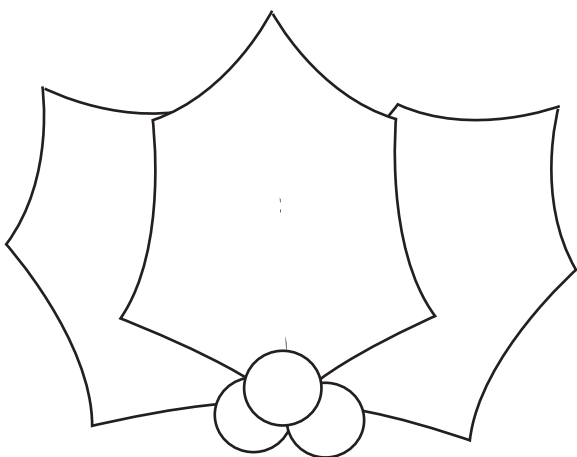
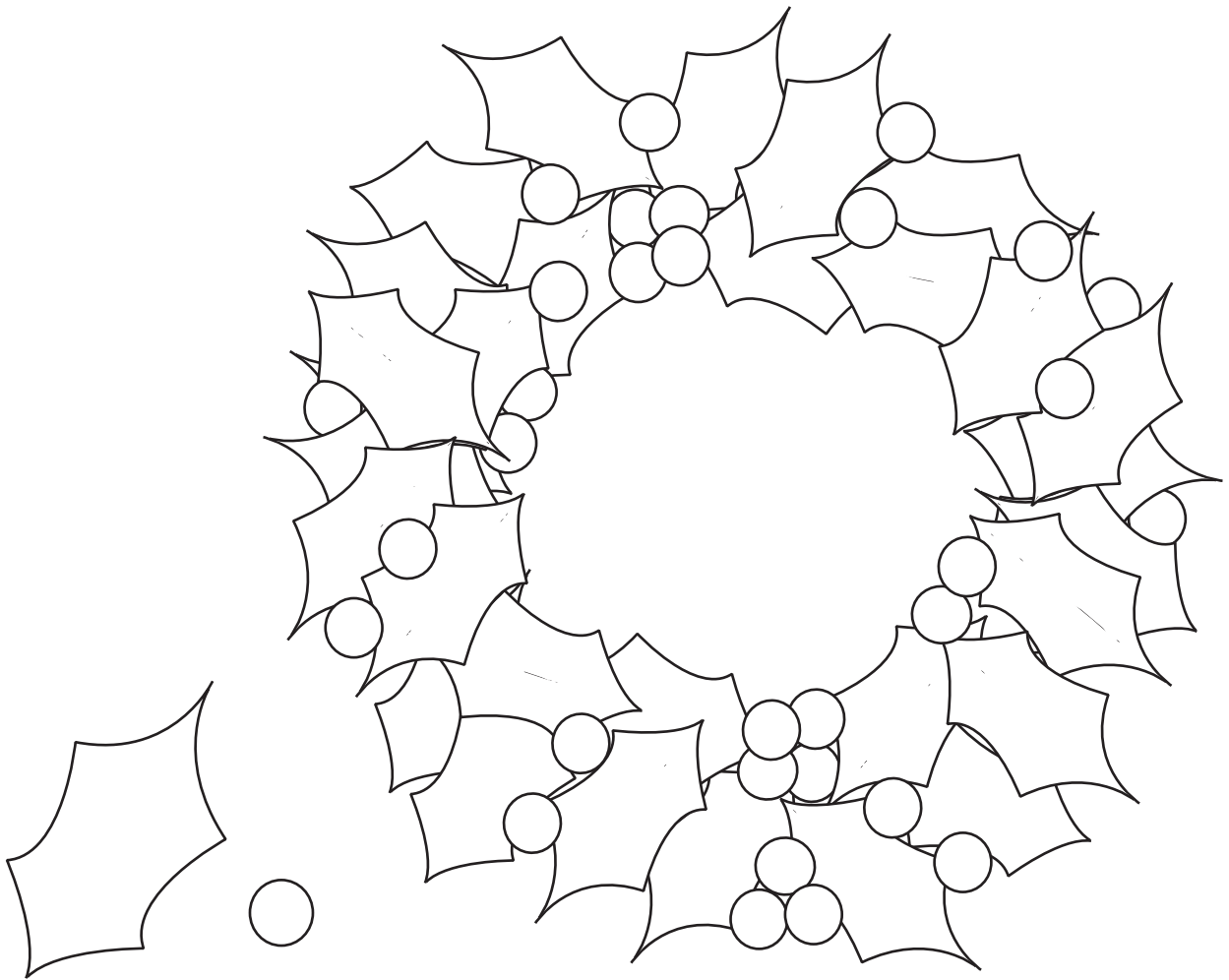

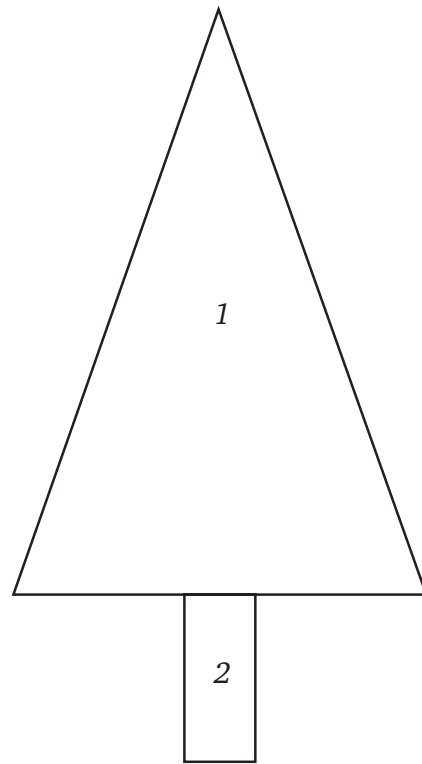
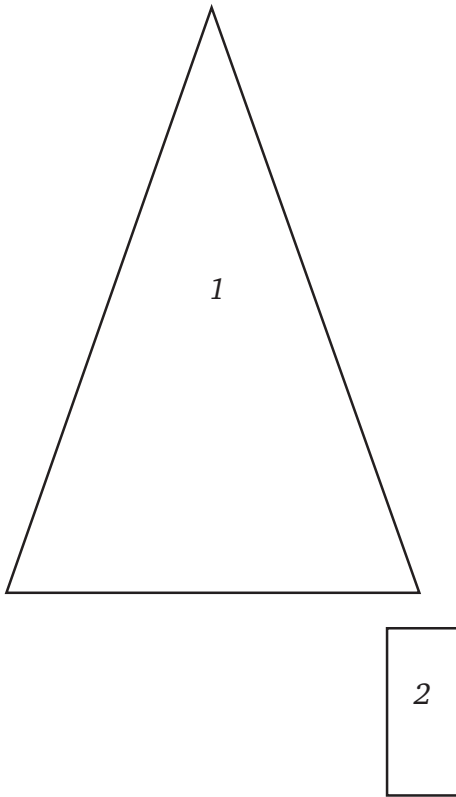
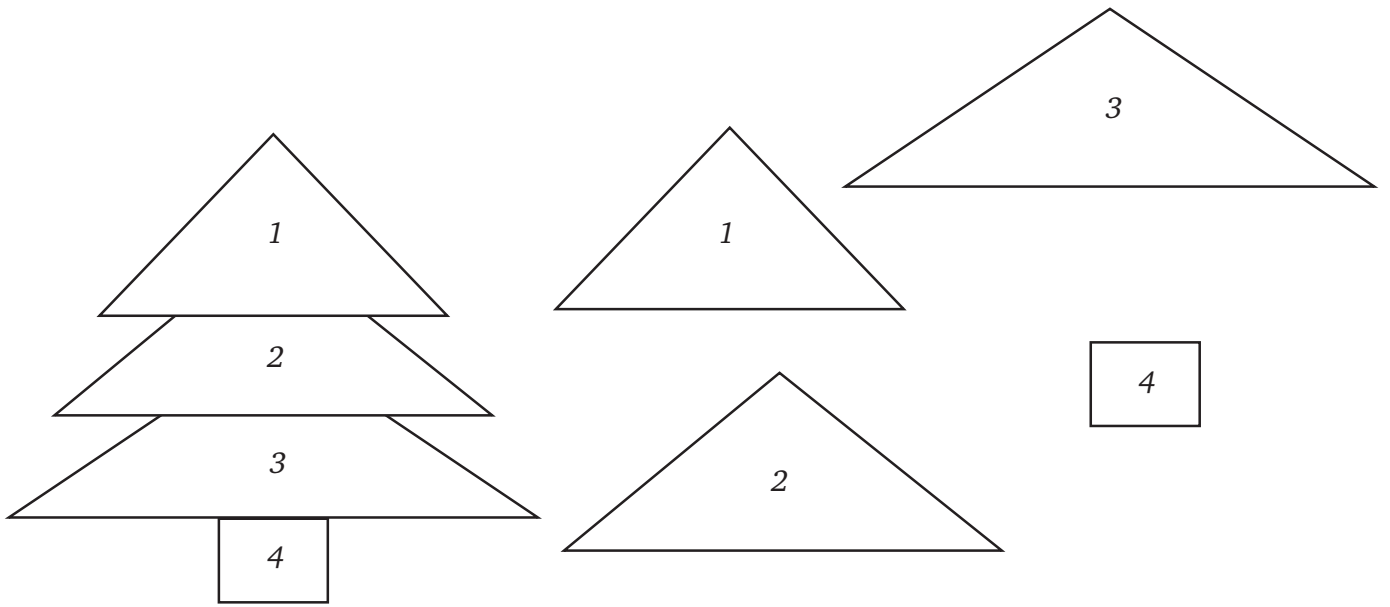

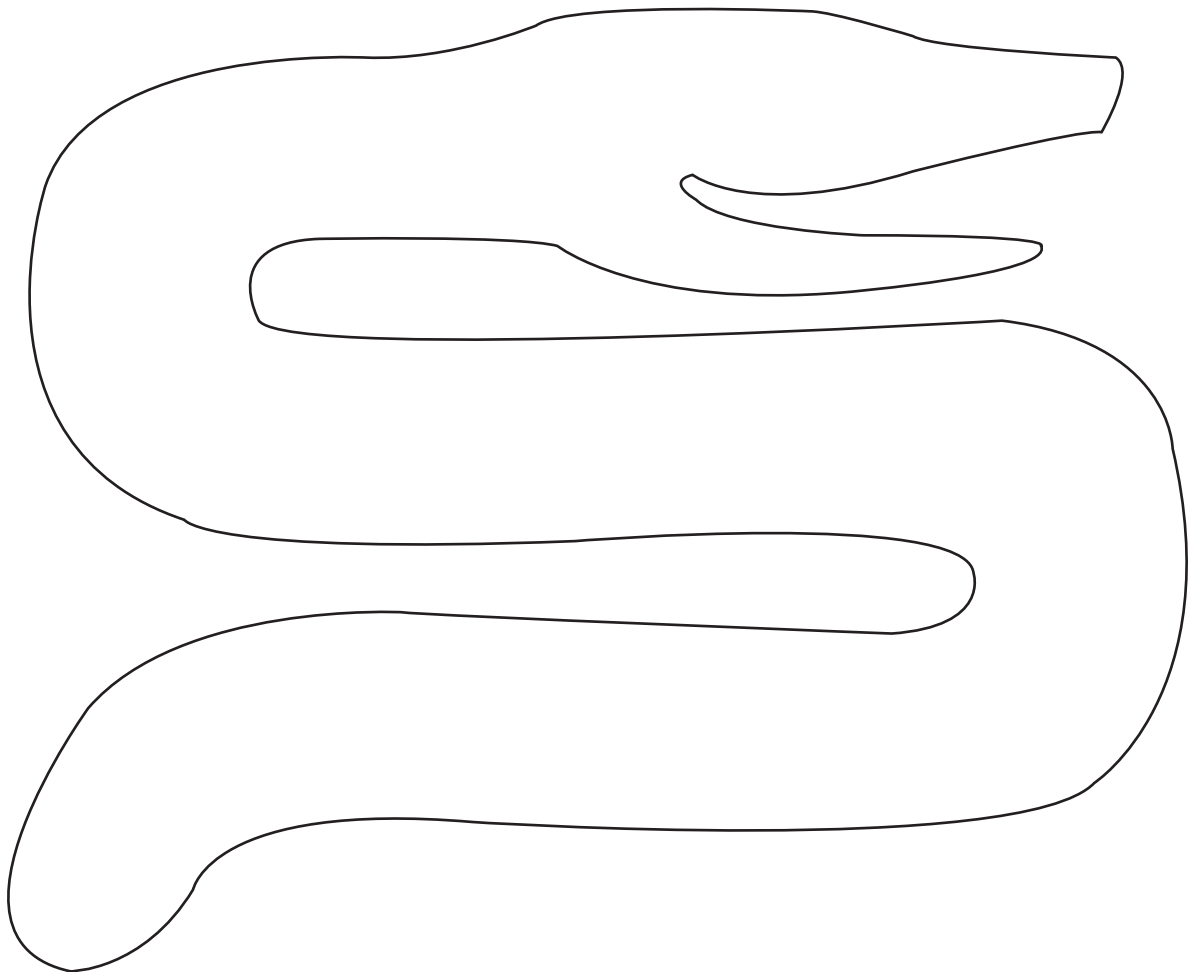
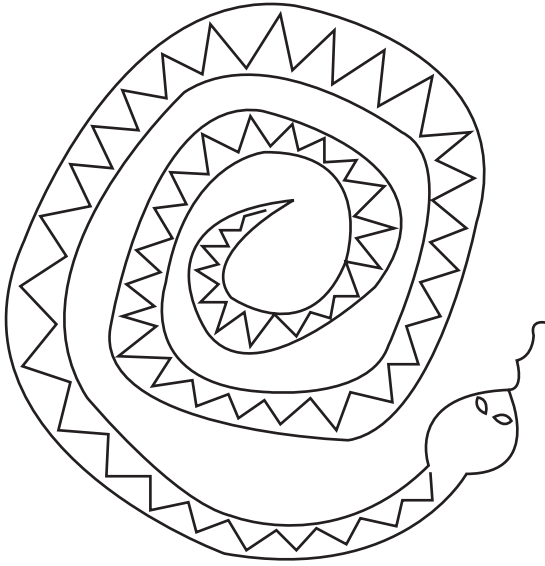

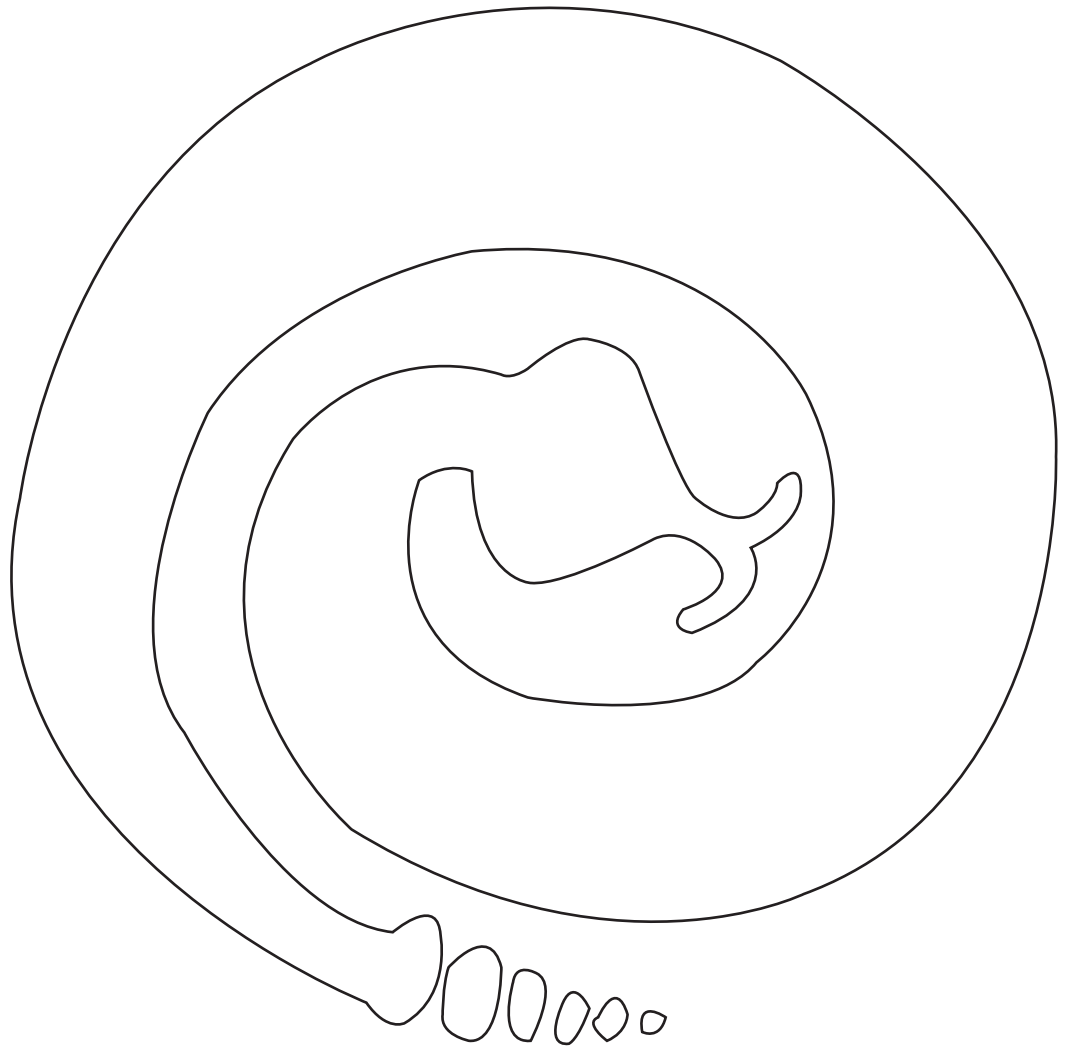

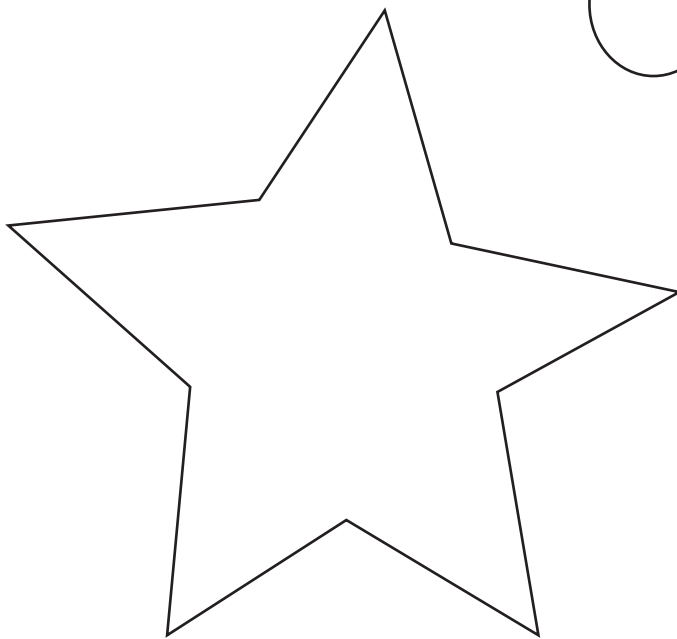
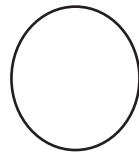
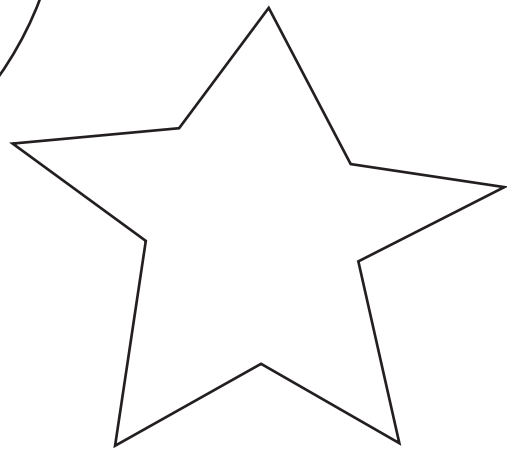
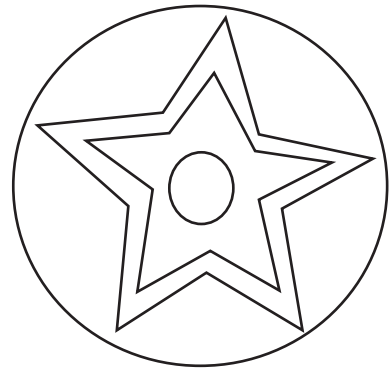
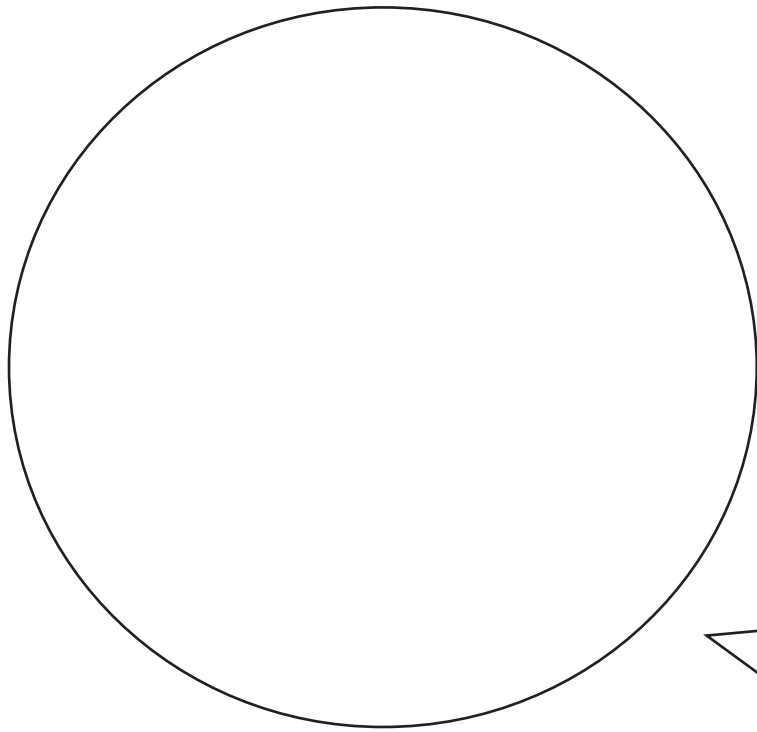

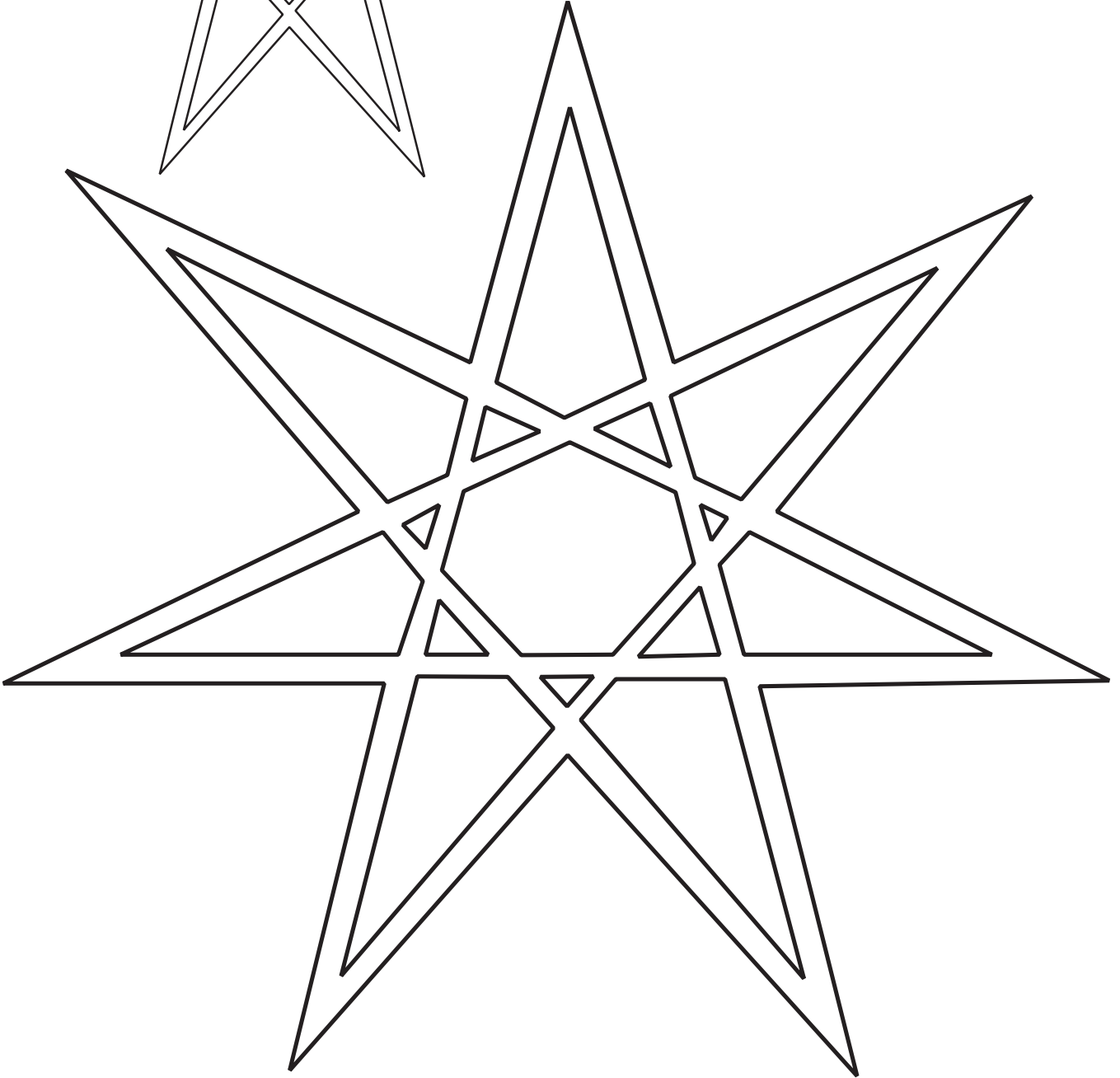
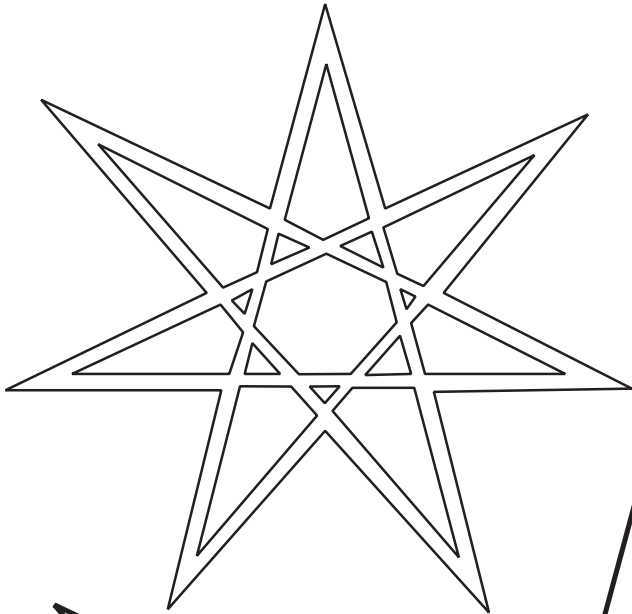

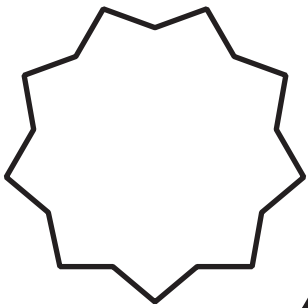
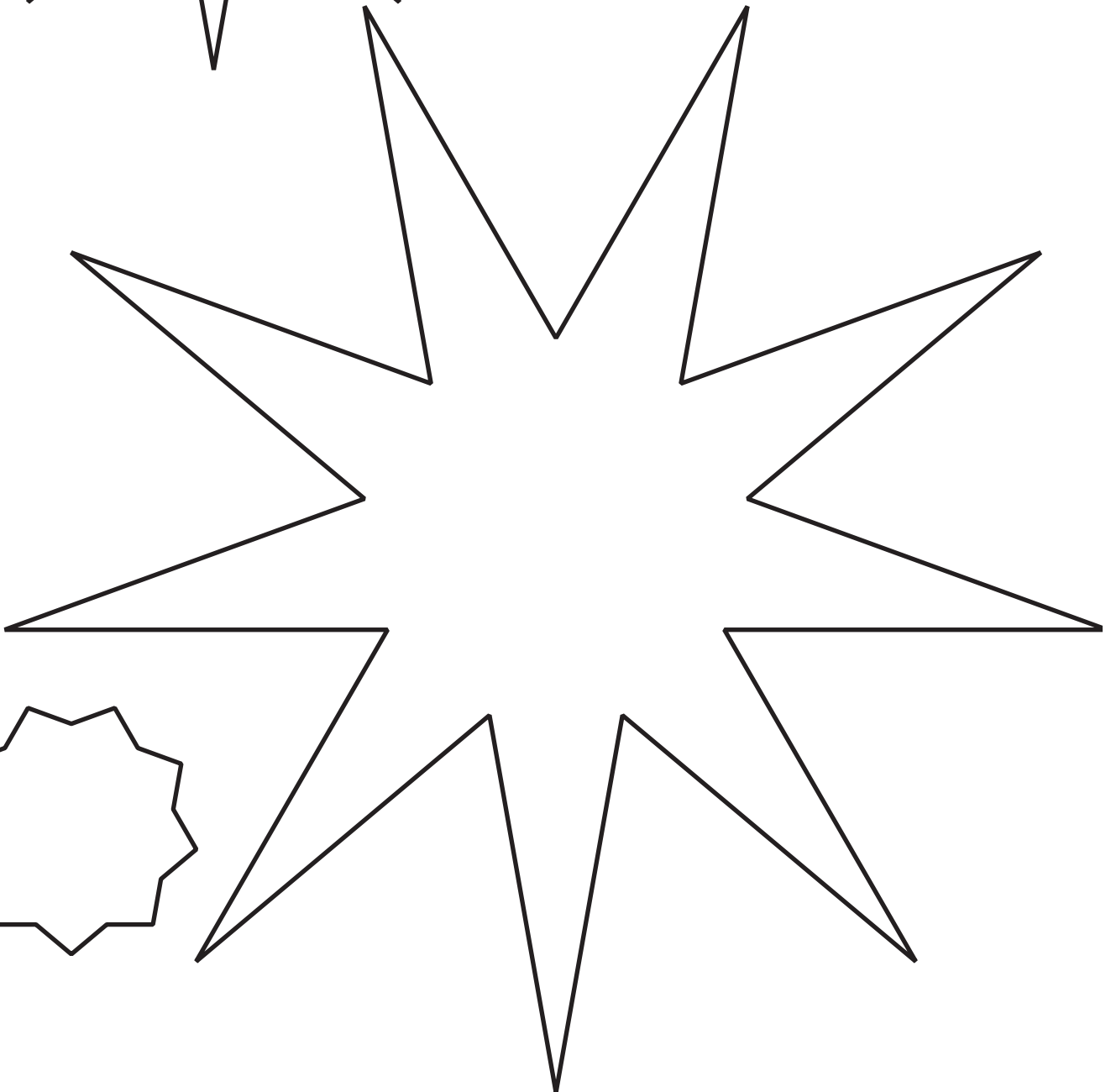
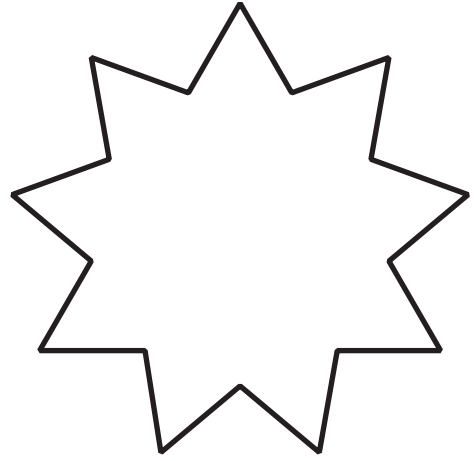
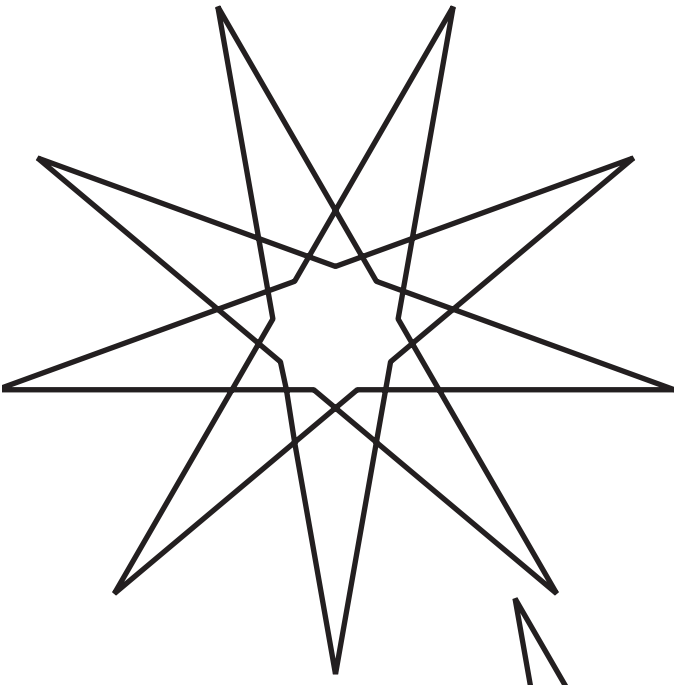

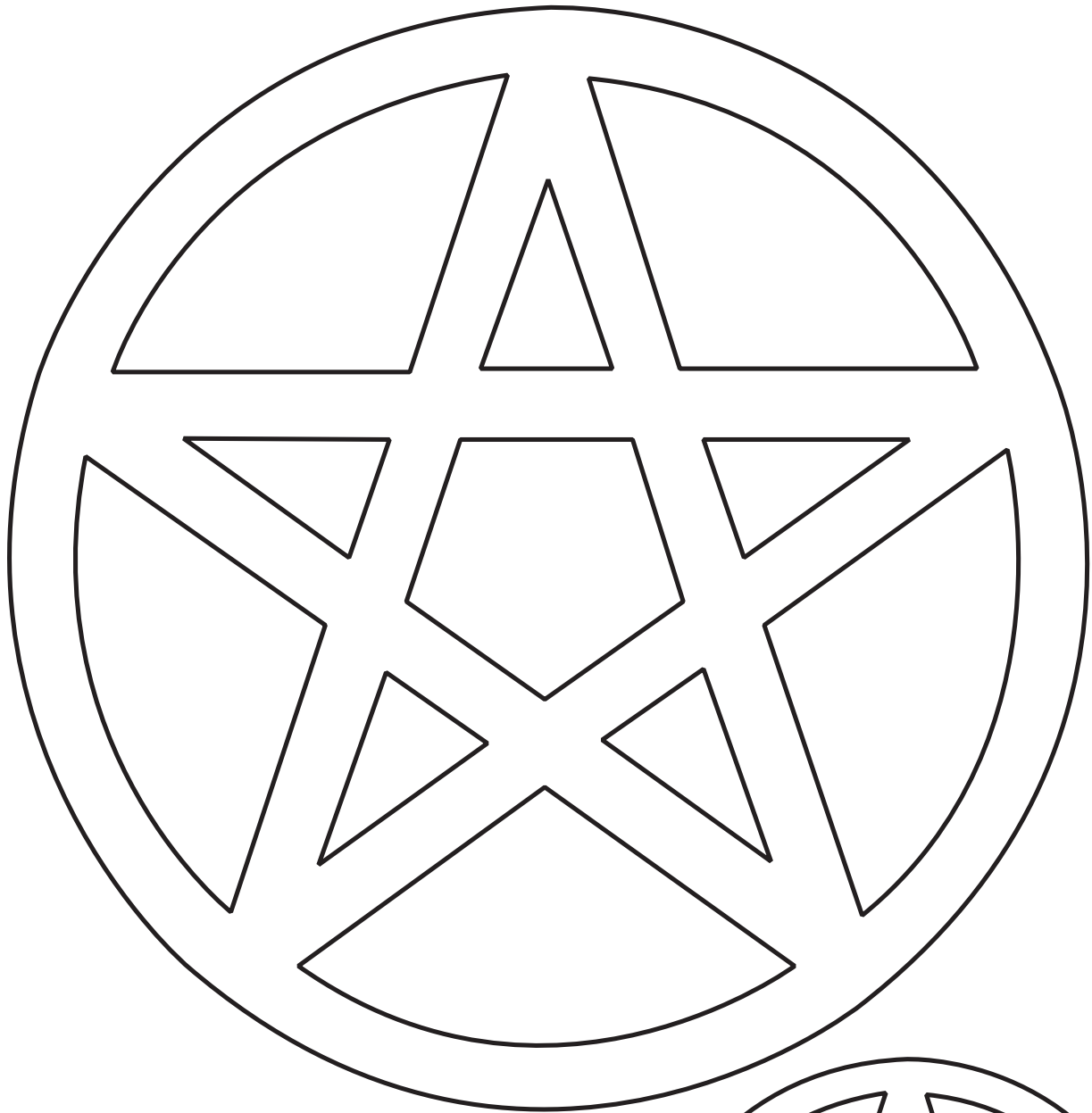

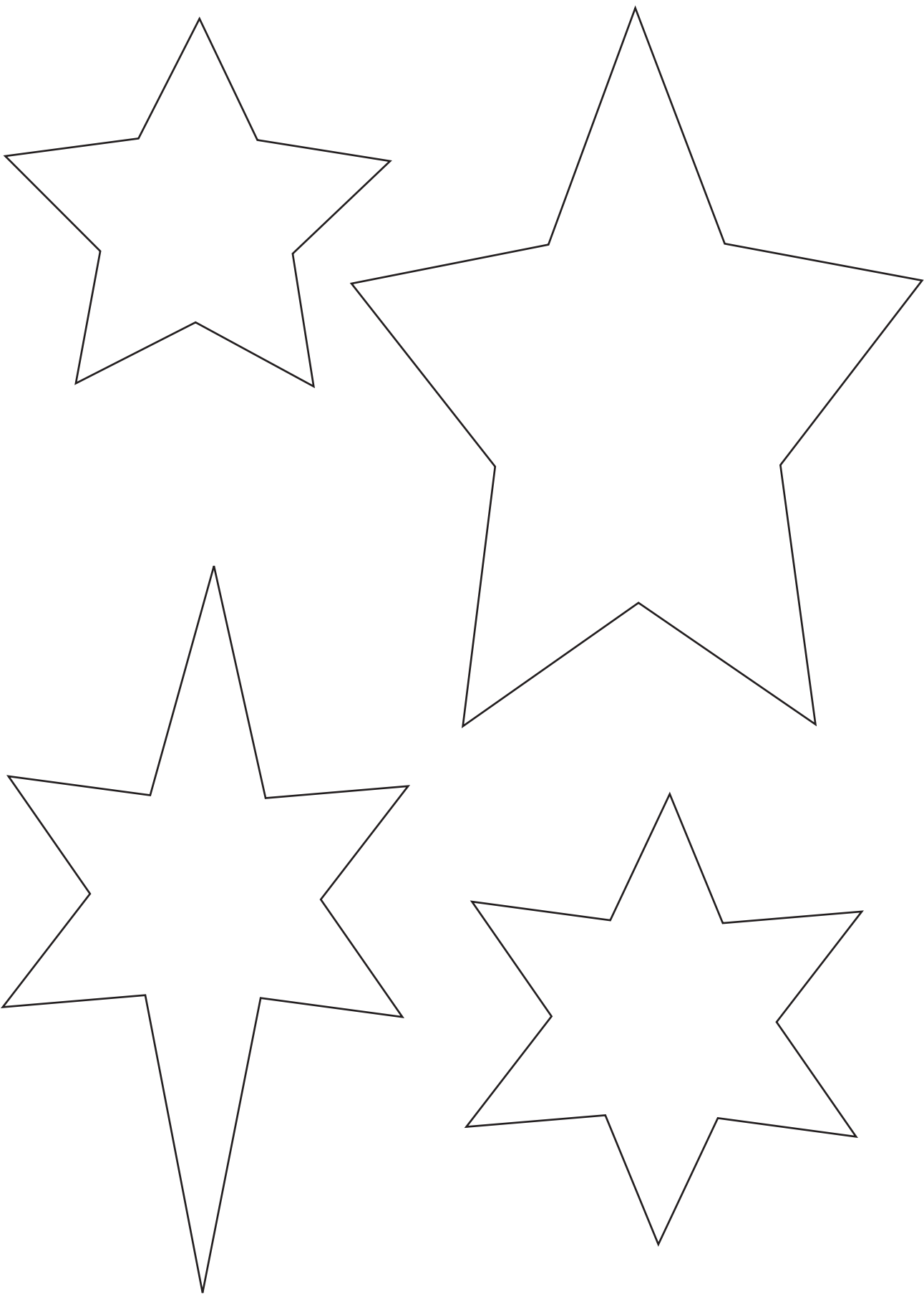

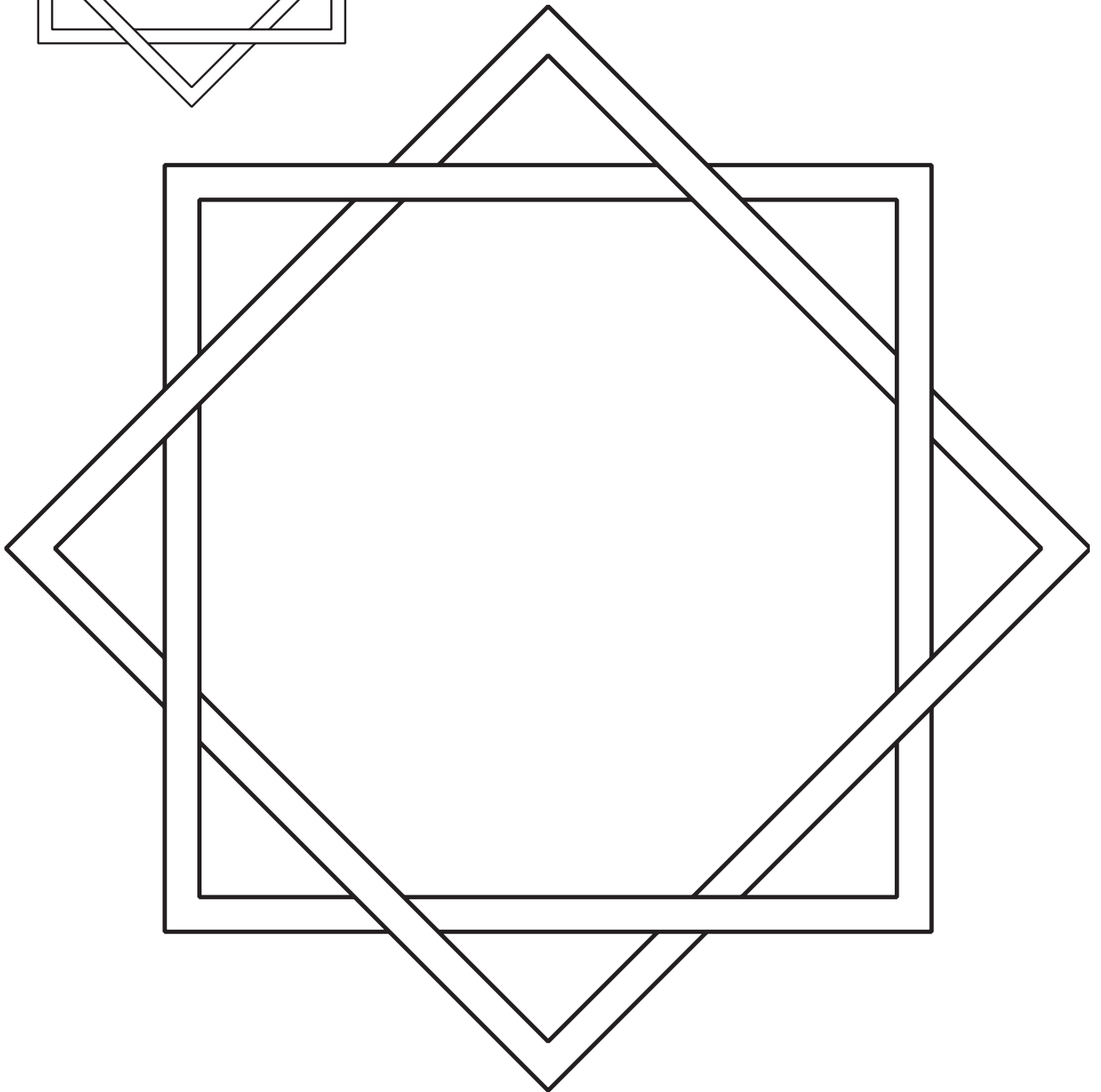
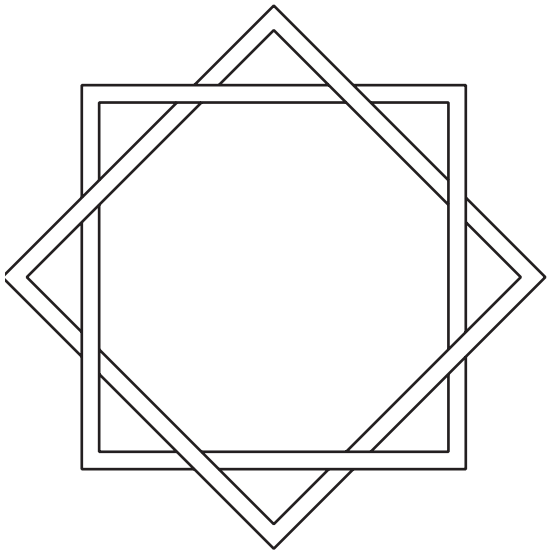

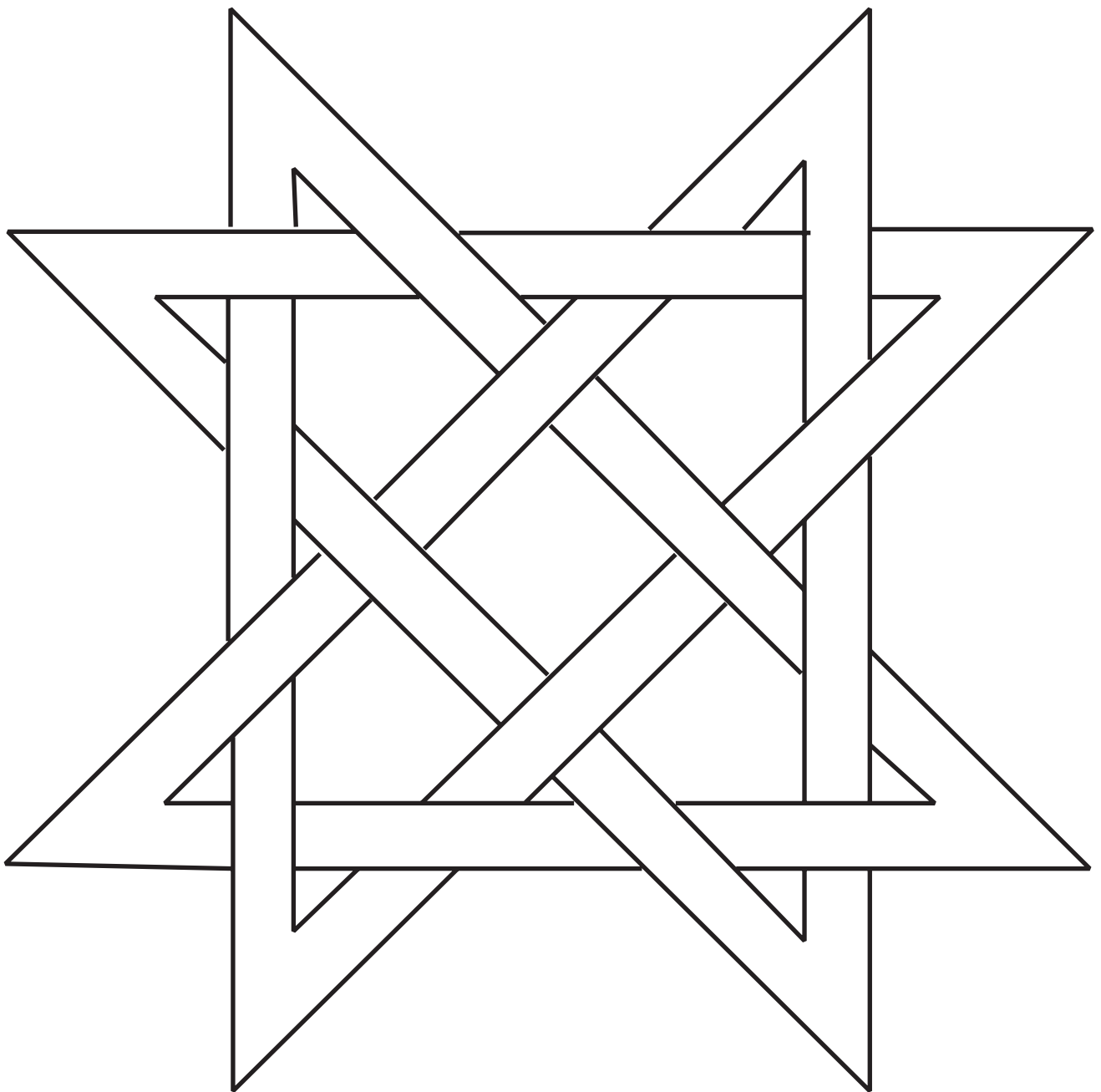
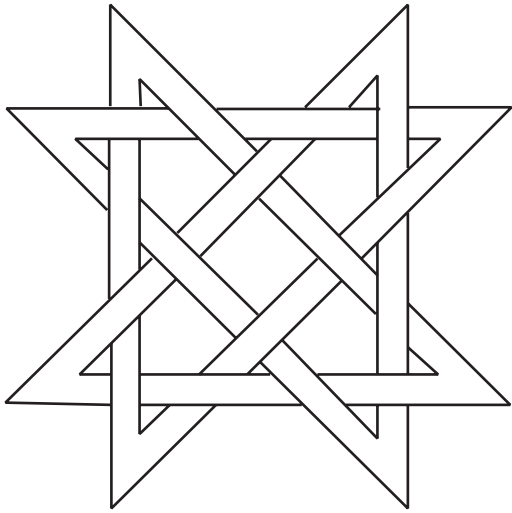

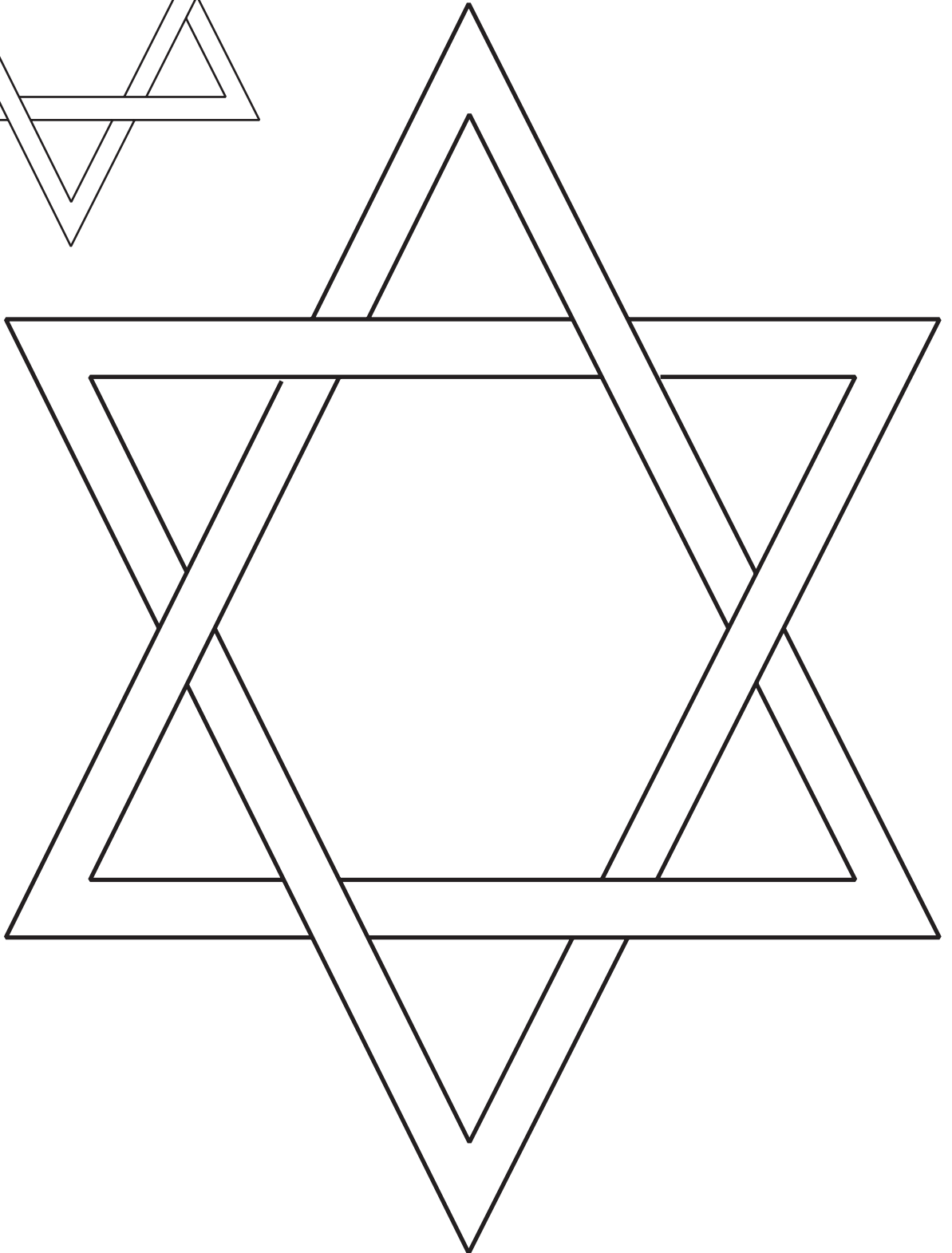
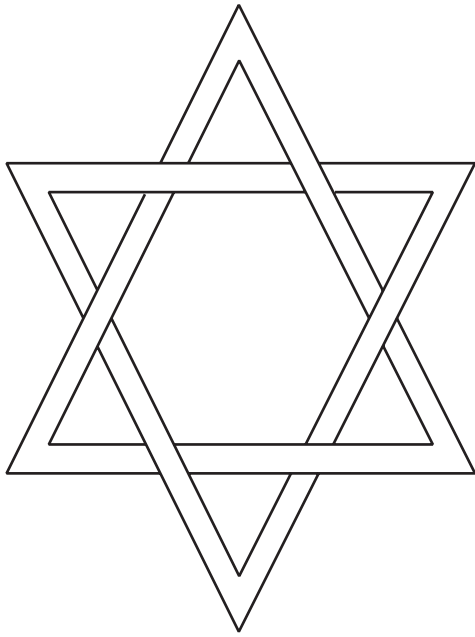

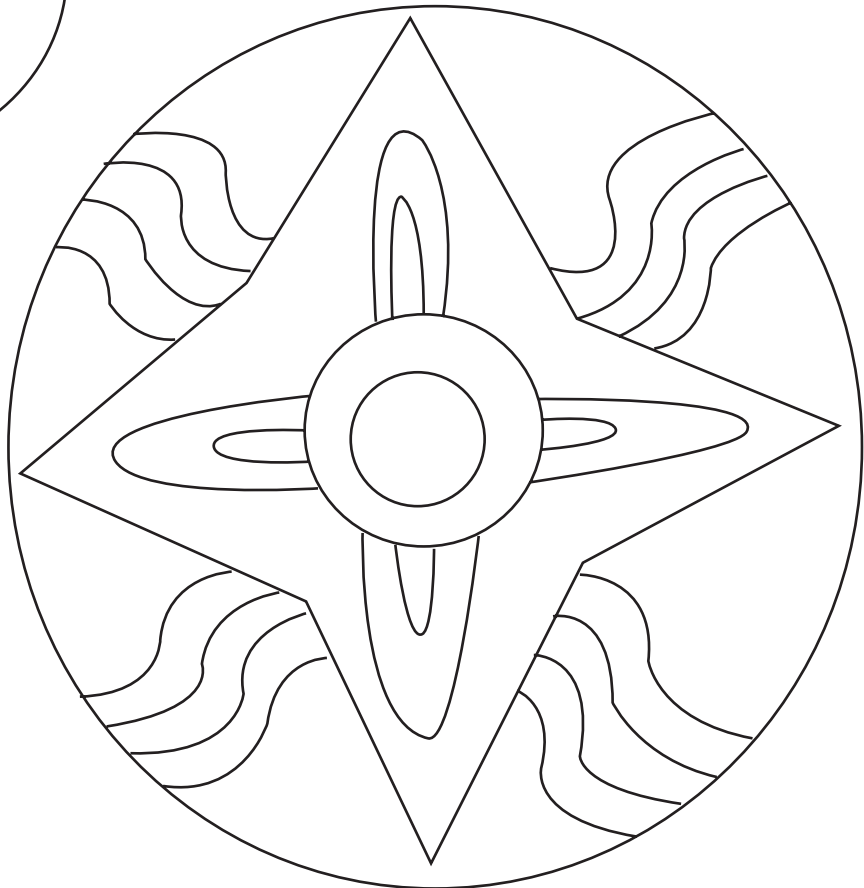
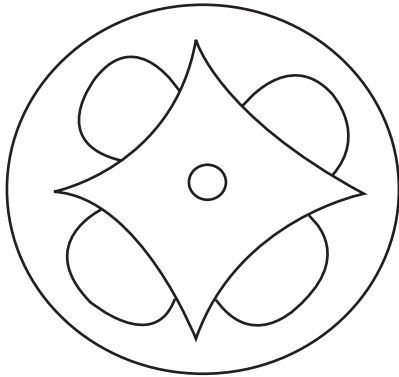
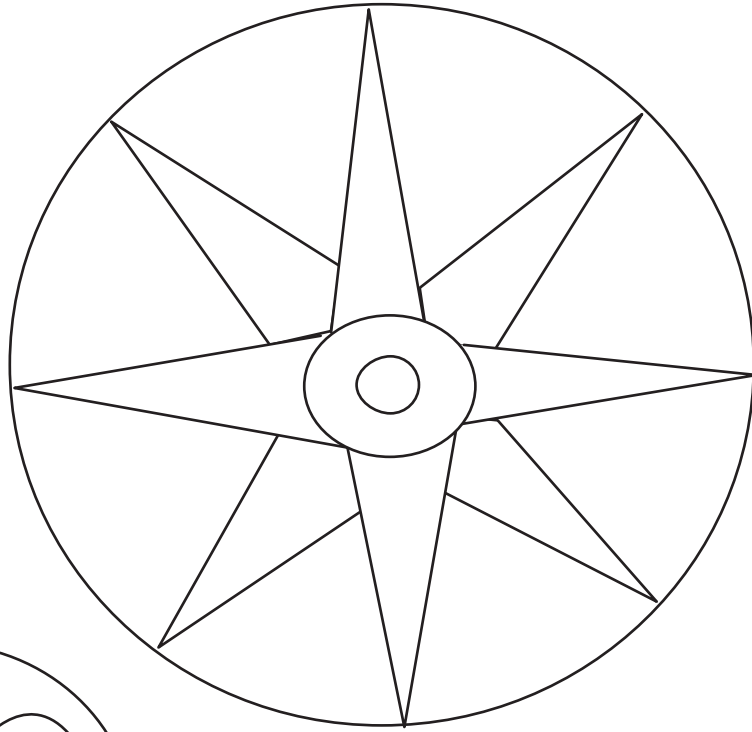

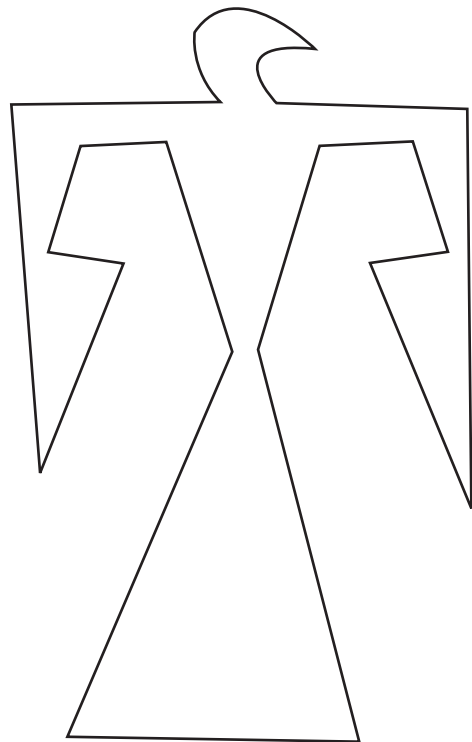
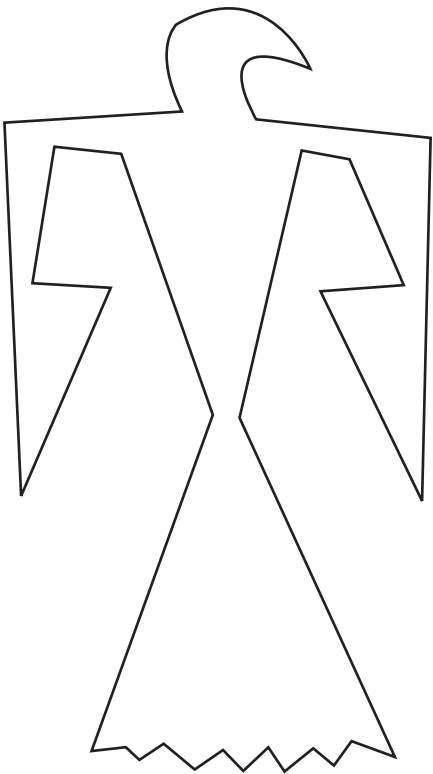
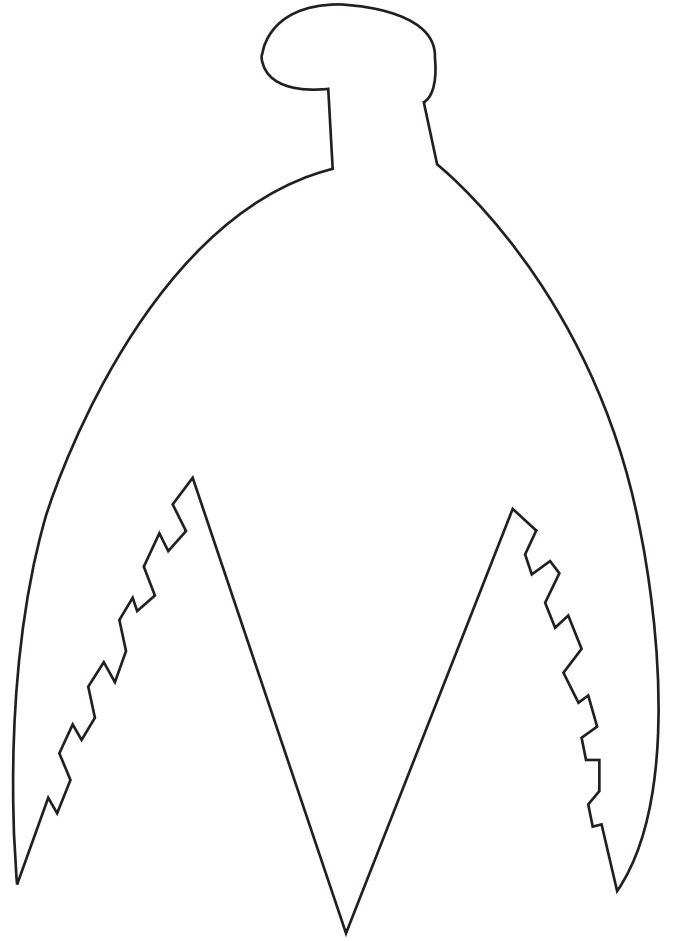
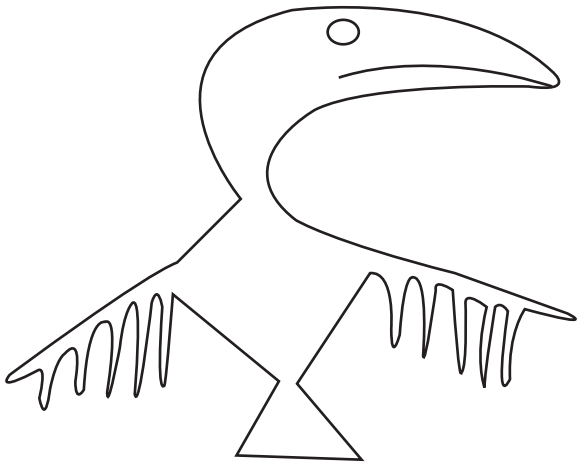

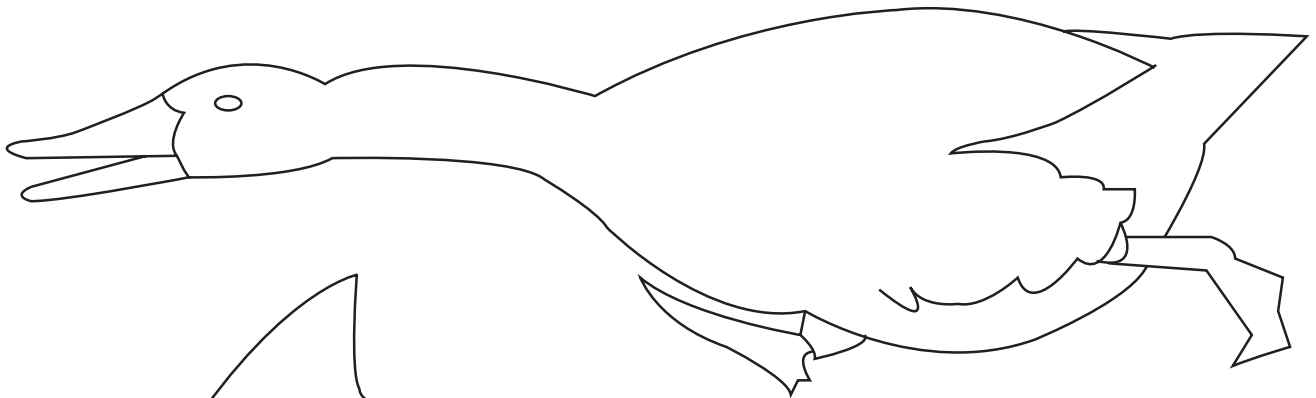
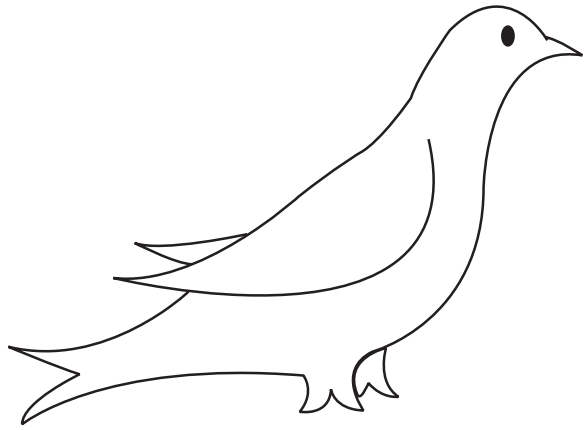

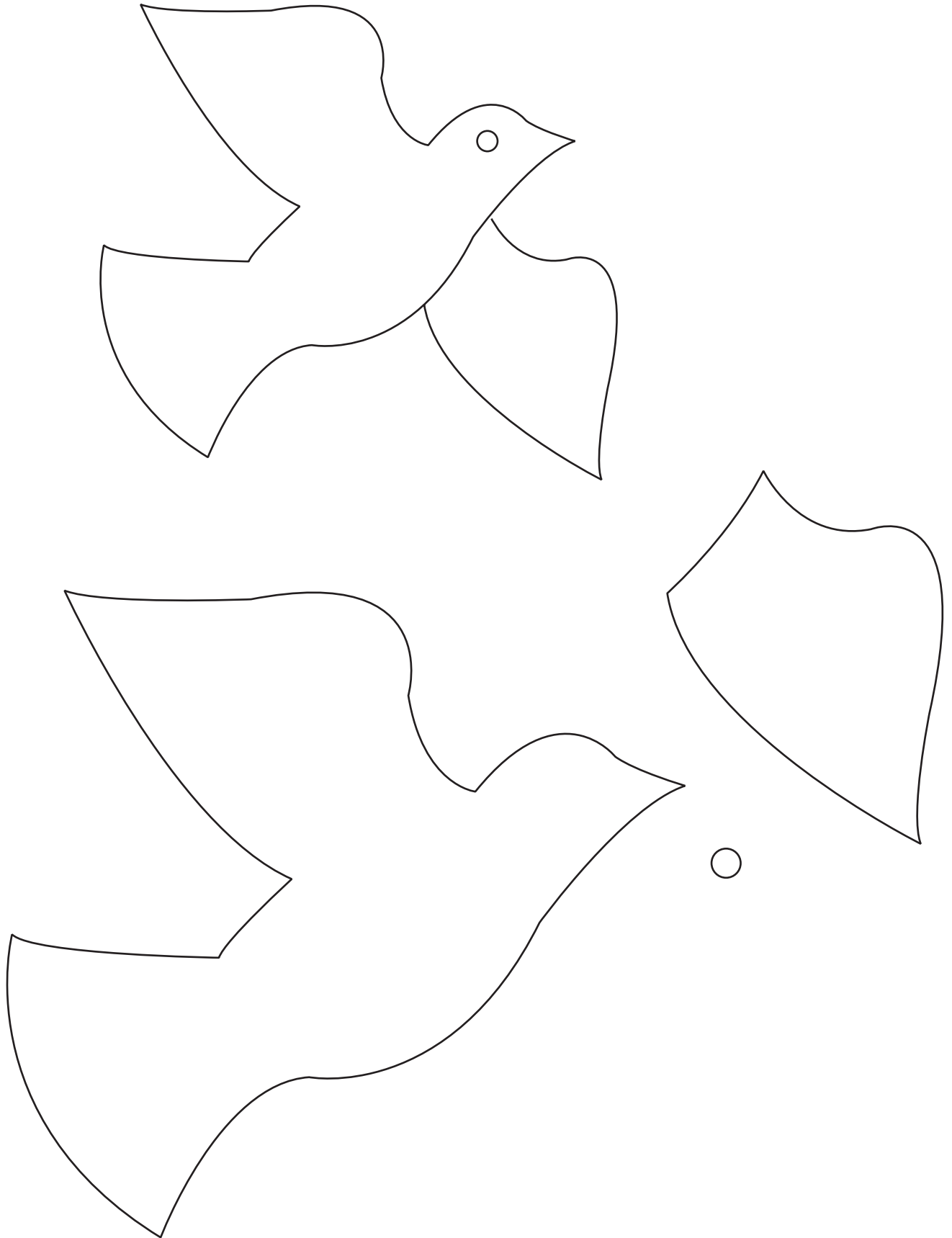

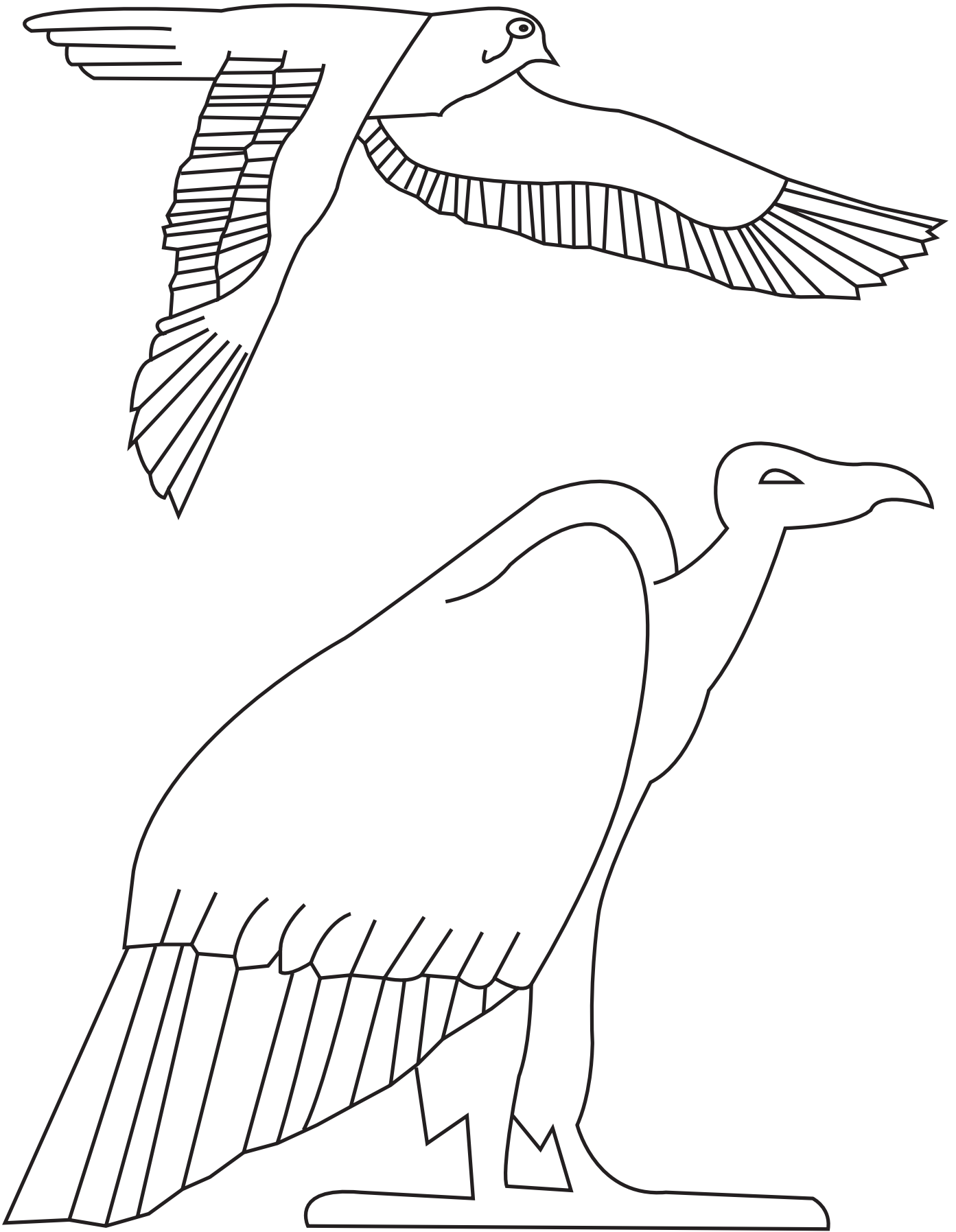

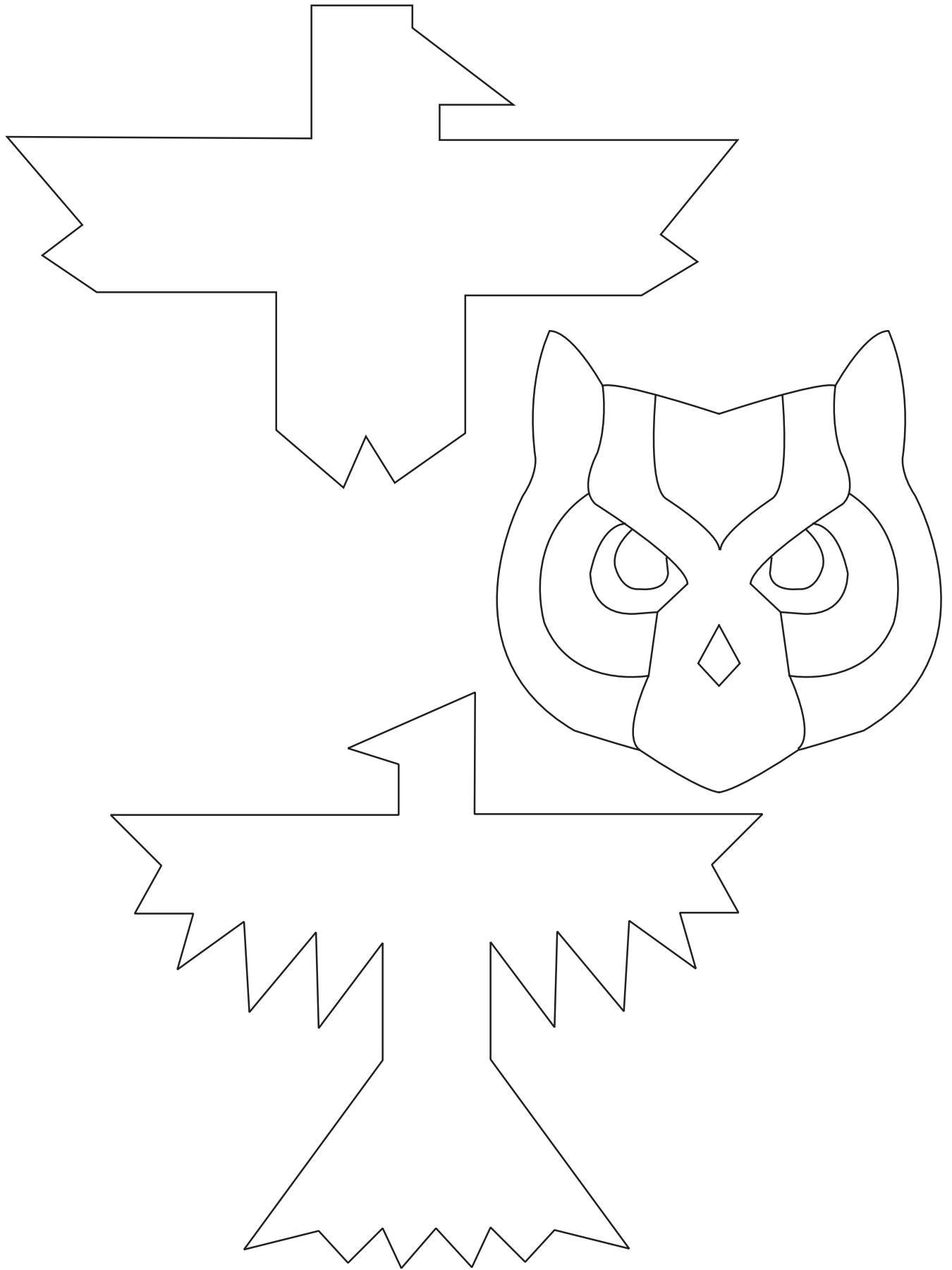

Bird Houses

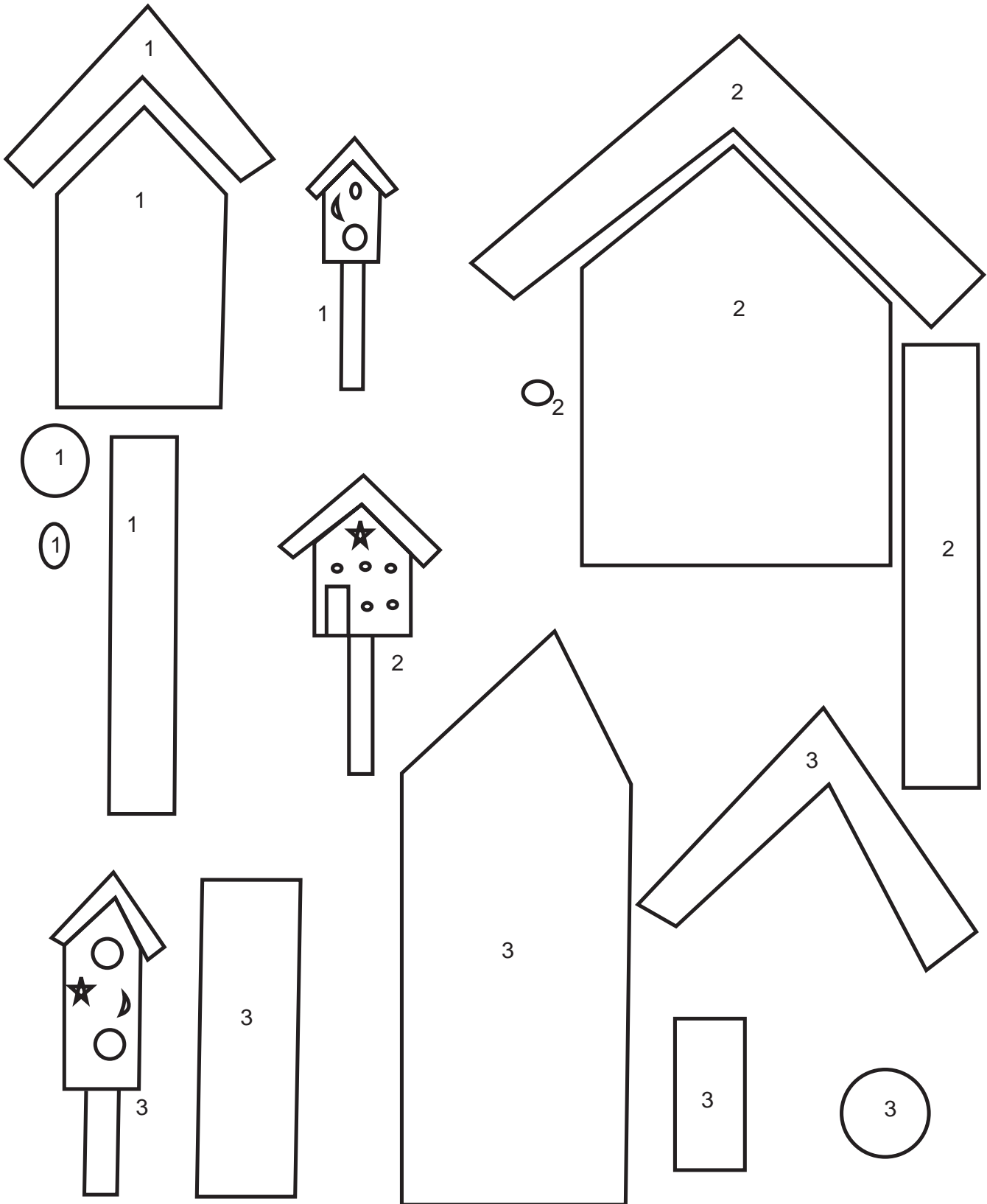

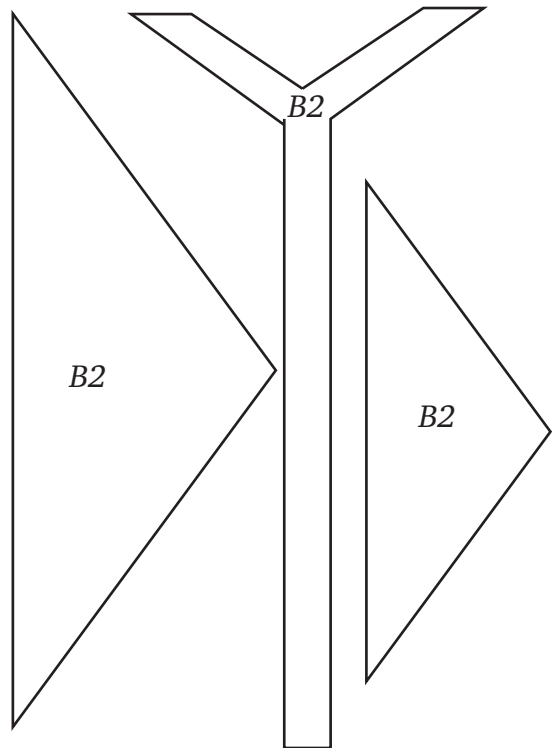
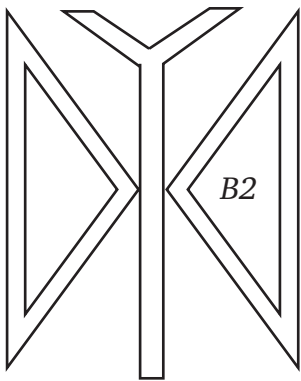
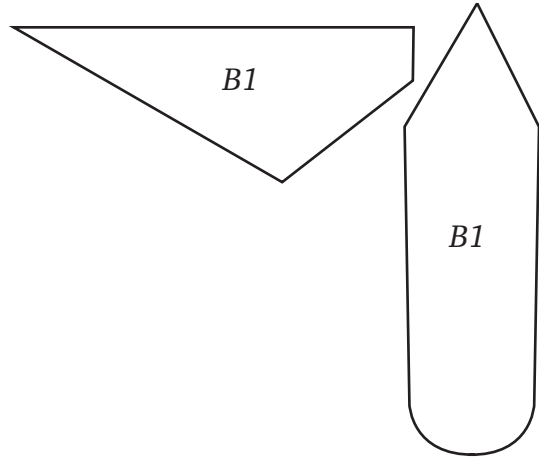
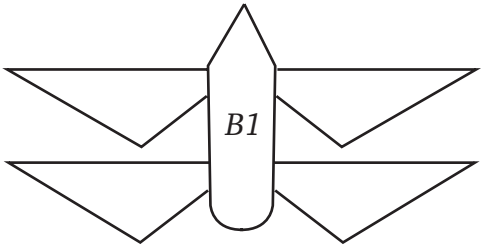

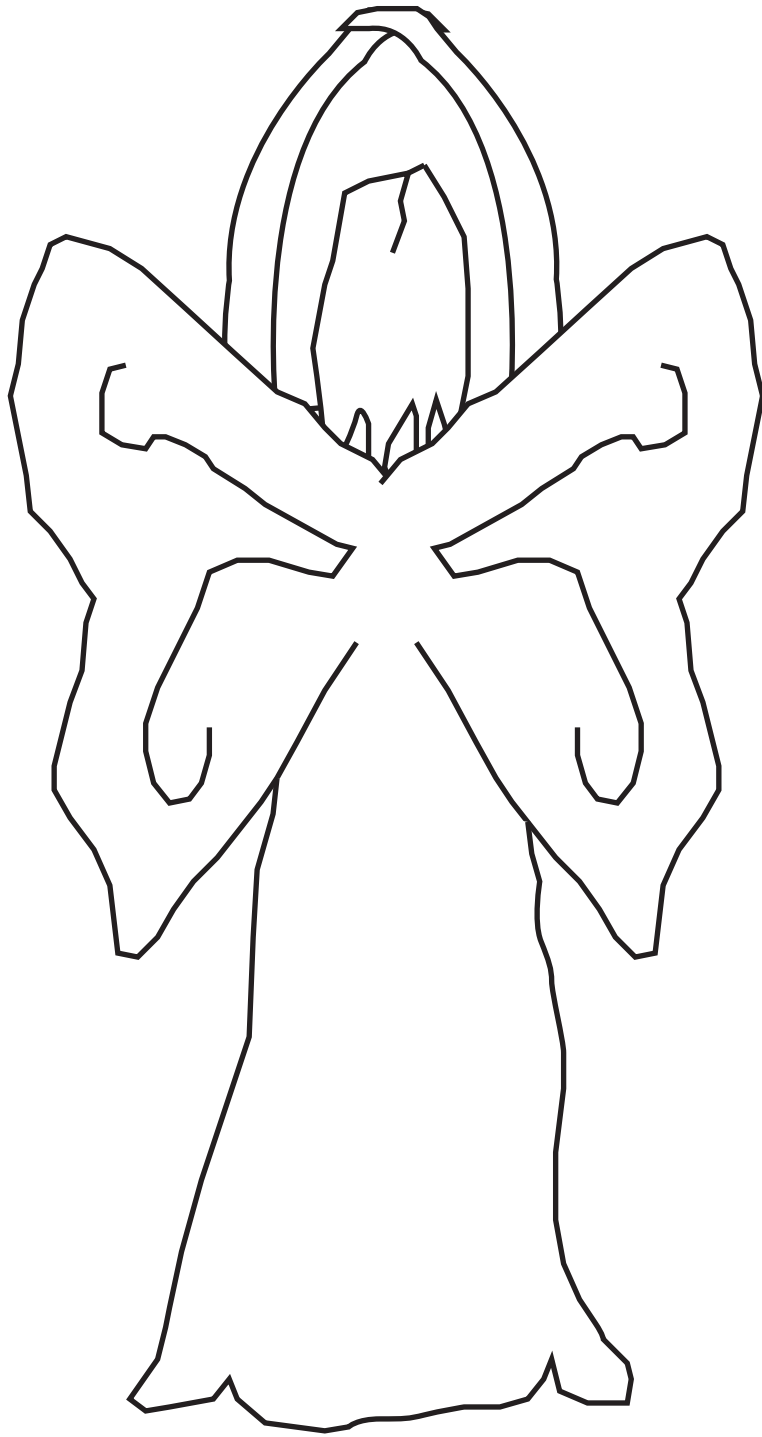

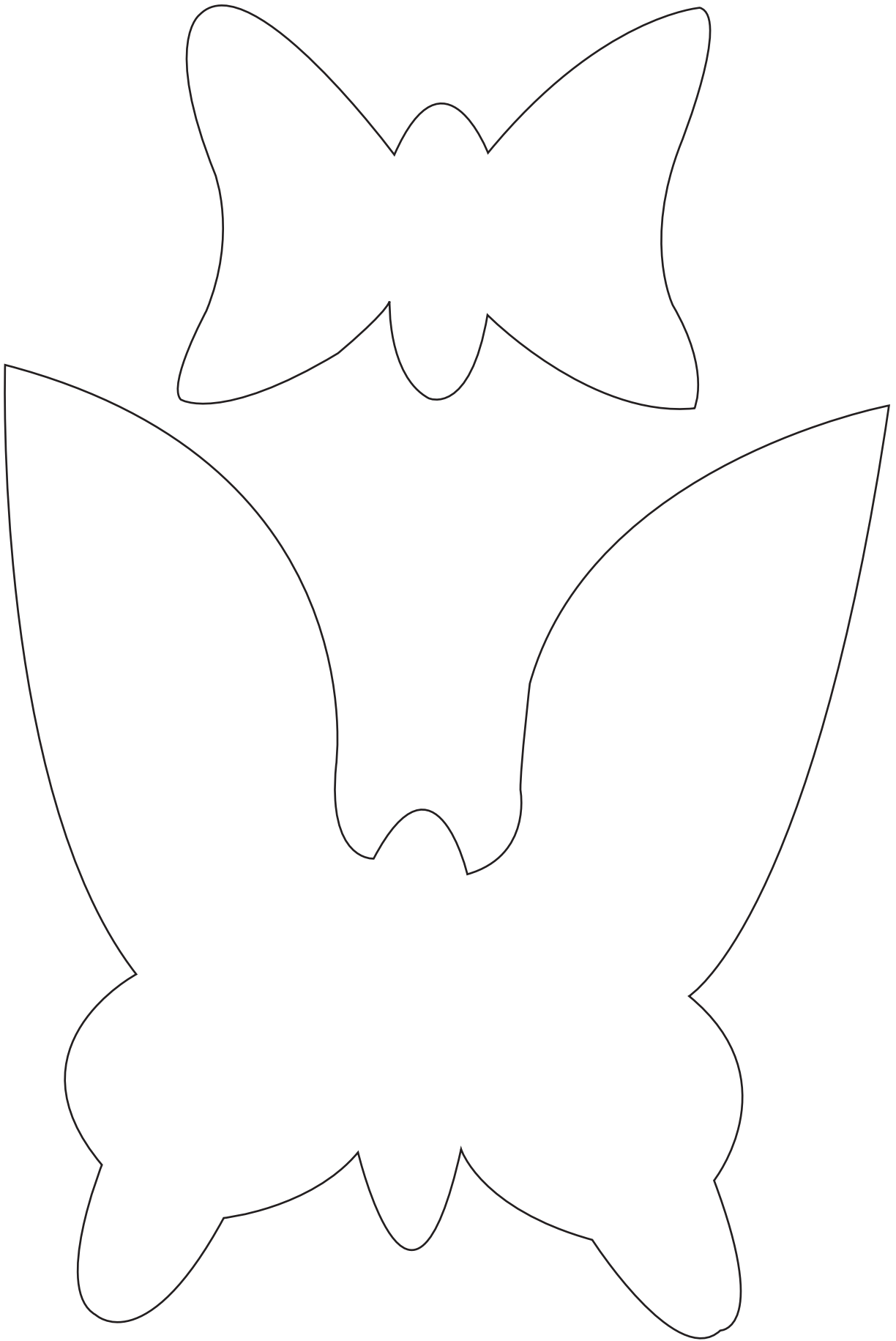

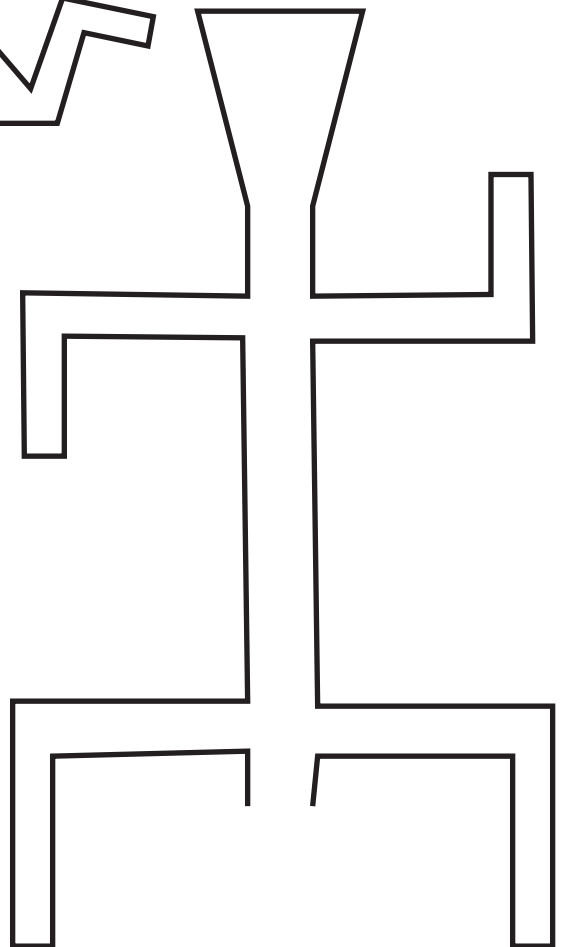
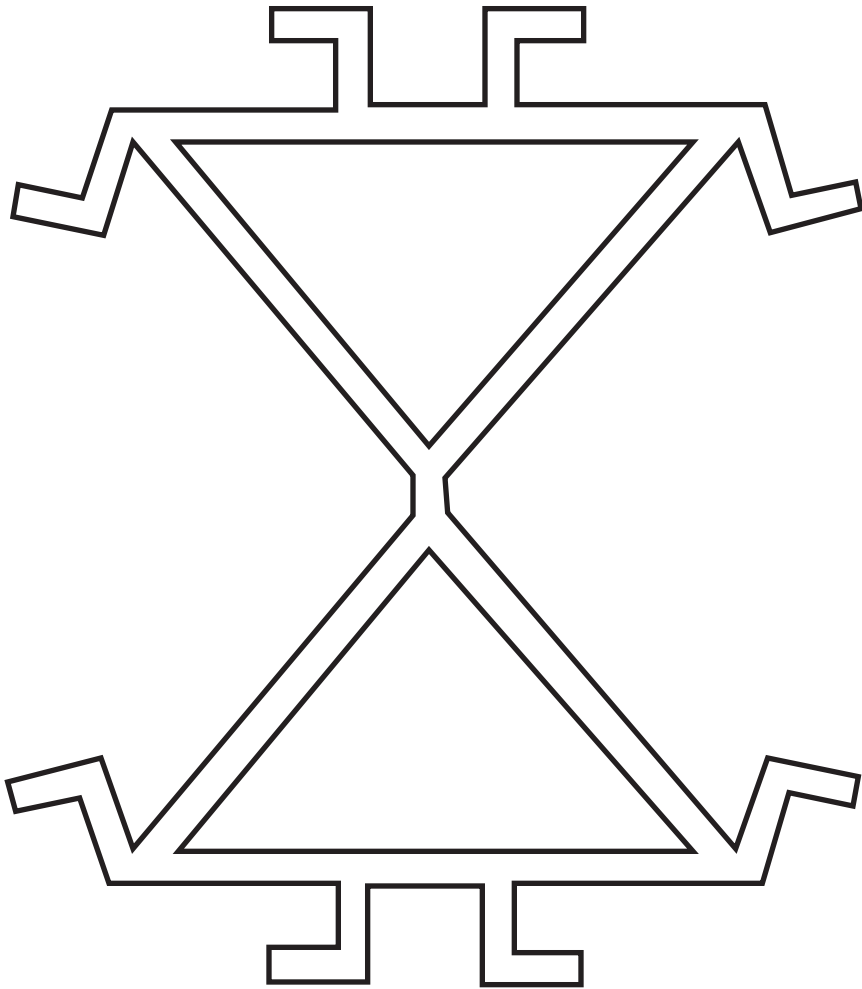

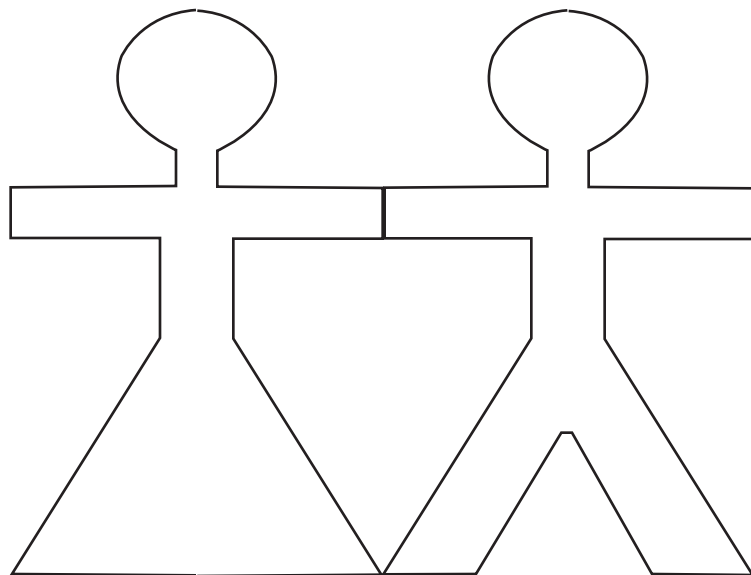
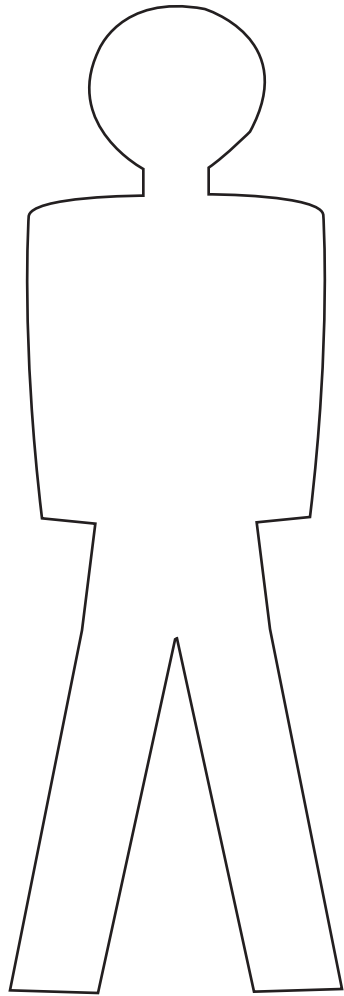
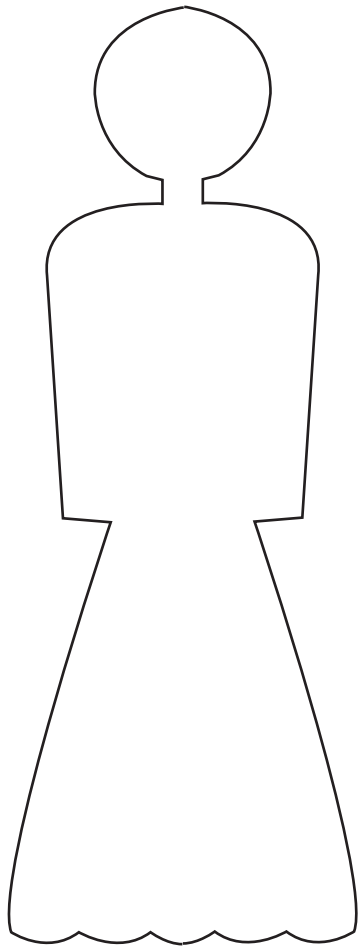

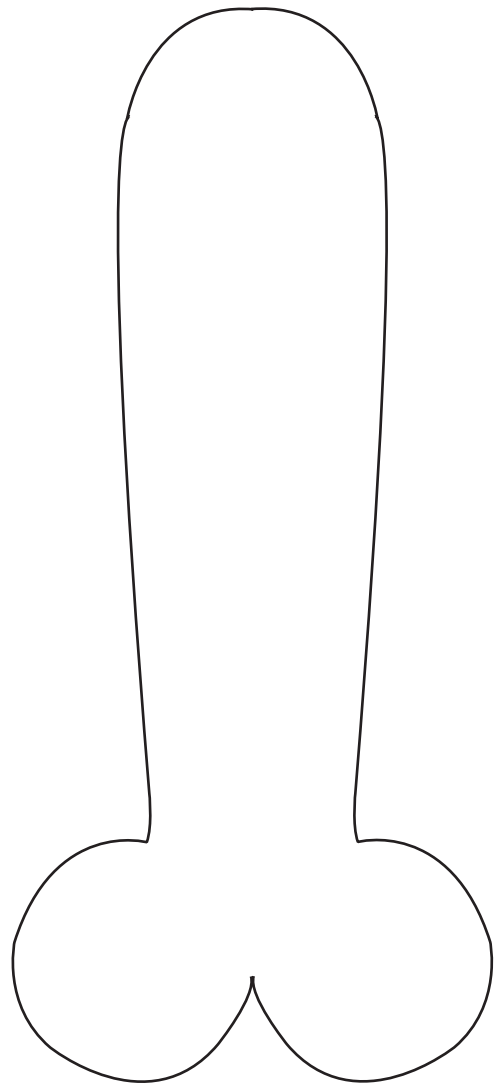
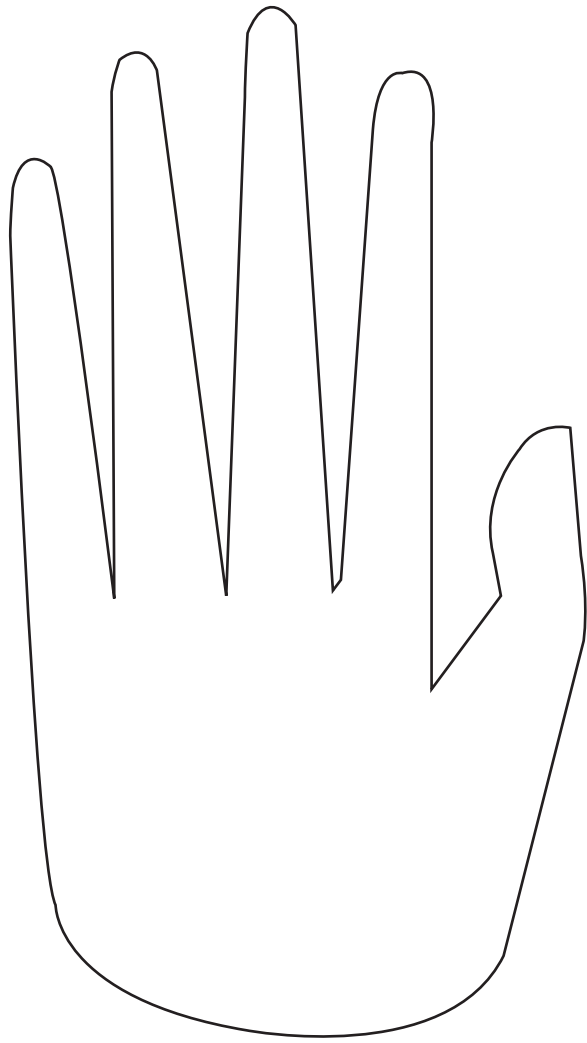

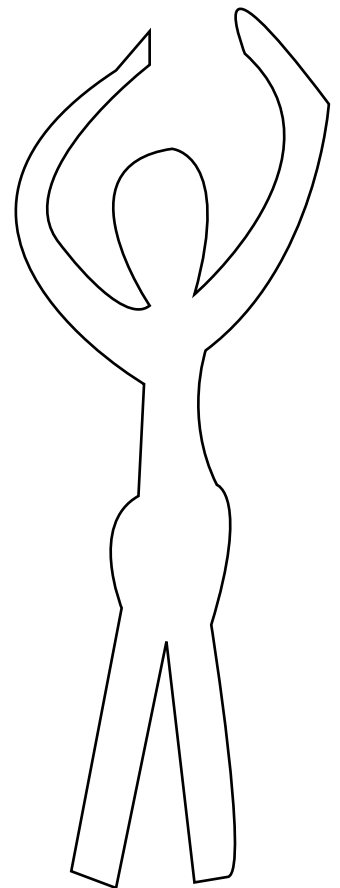
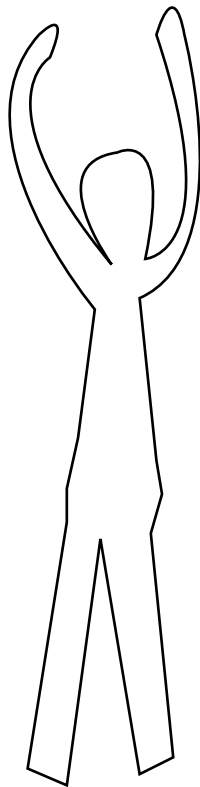
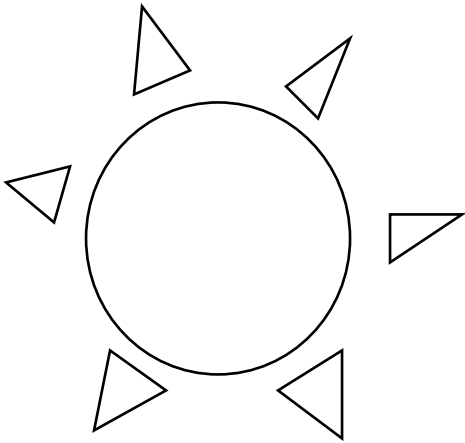
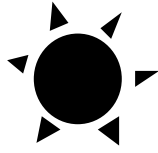

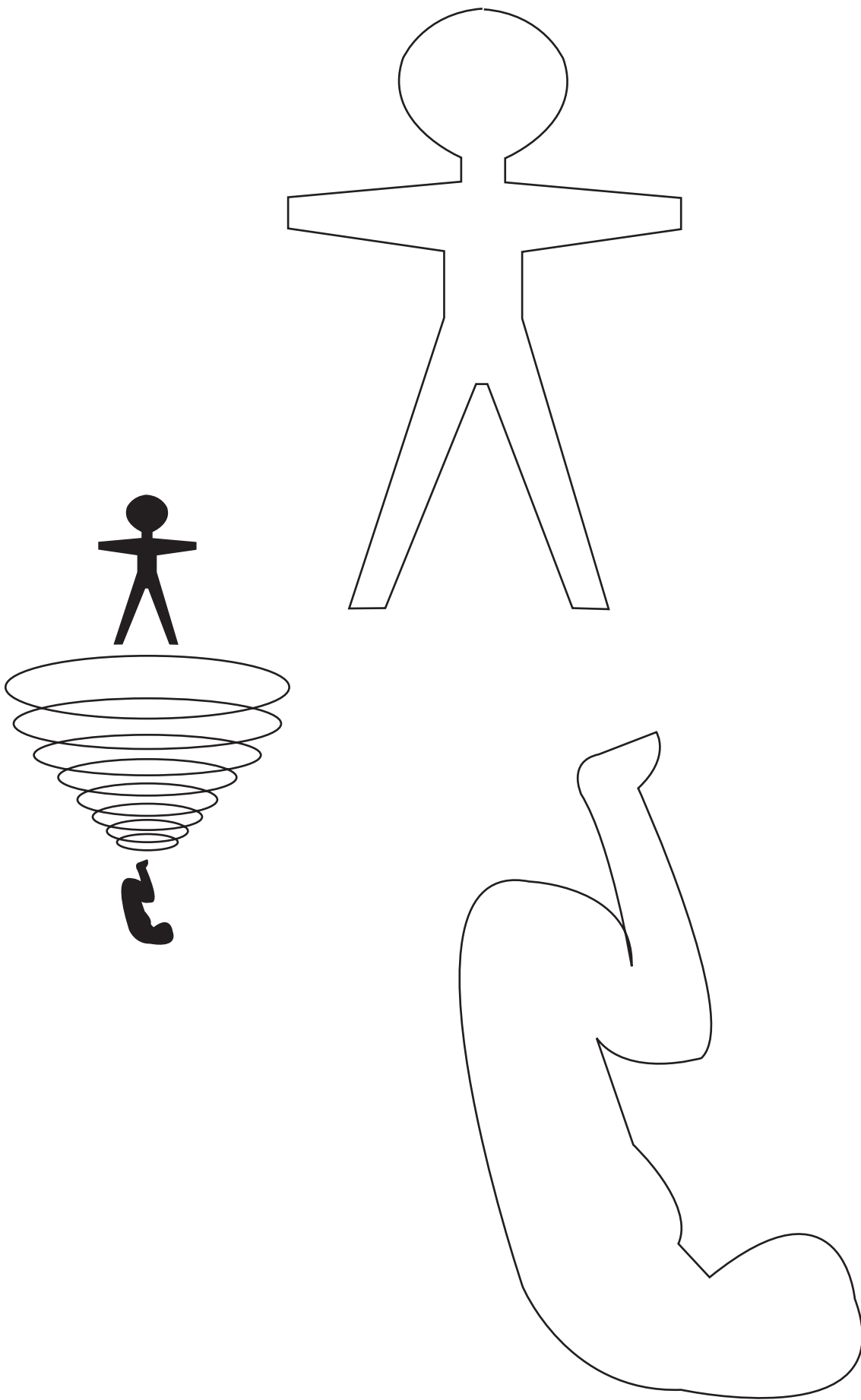

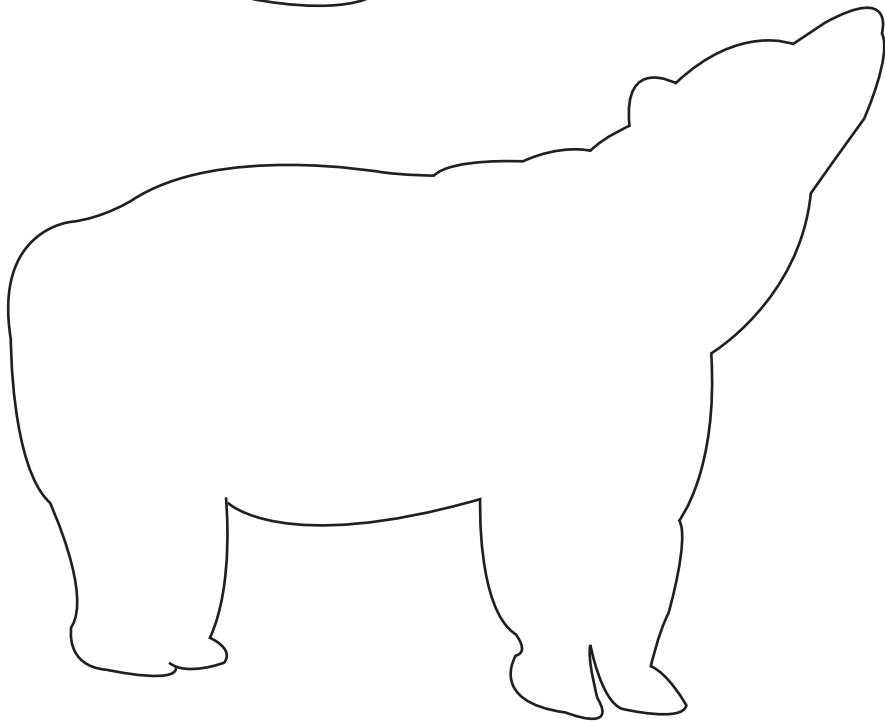
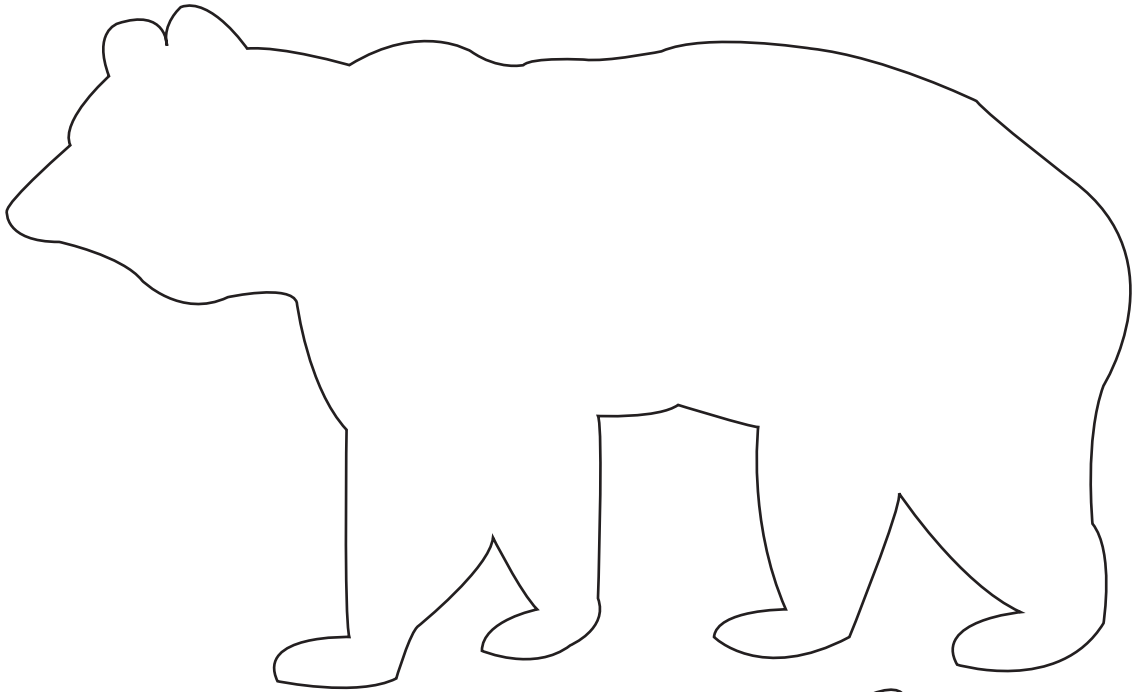
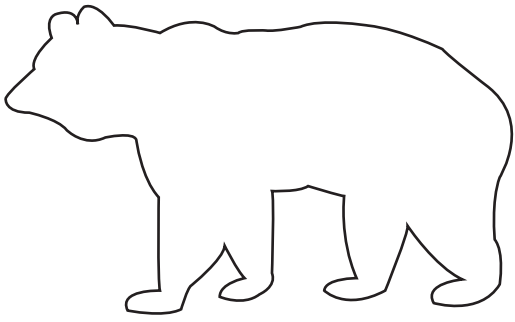

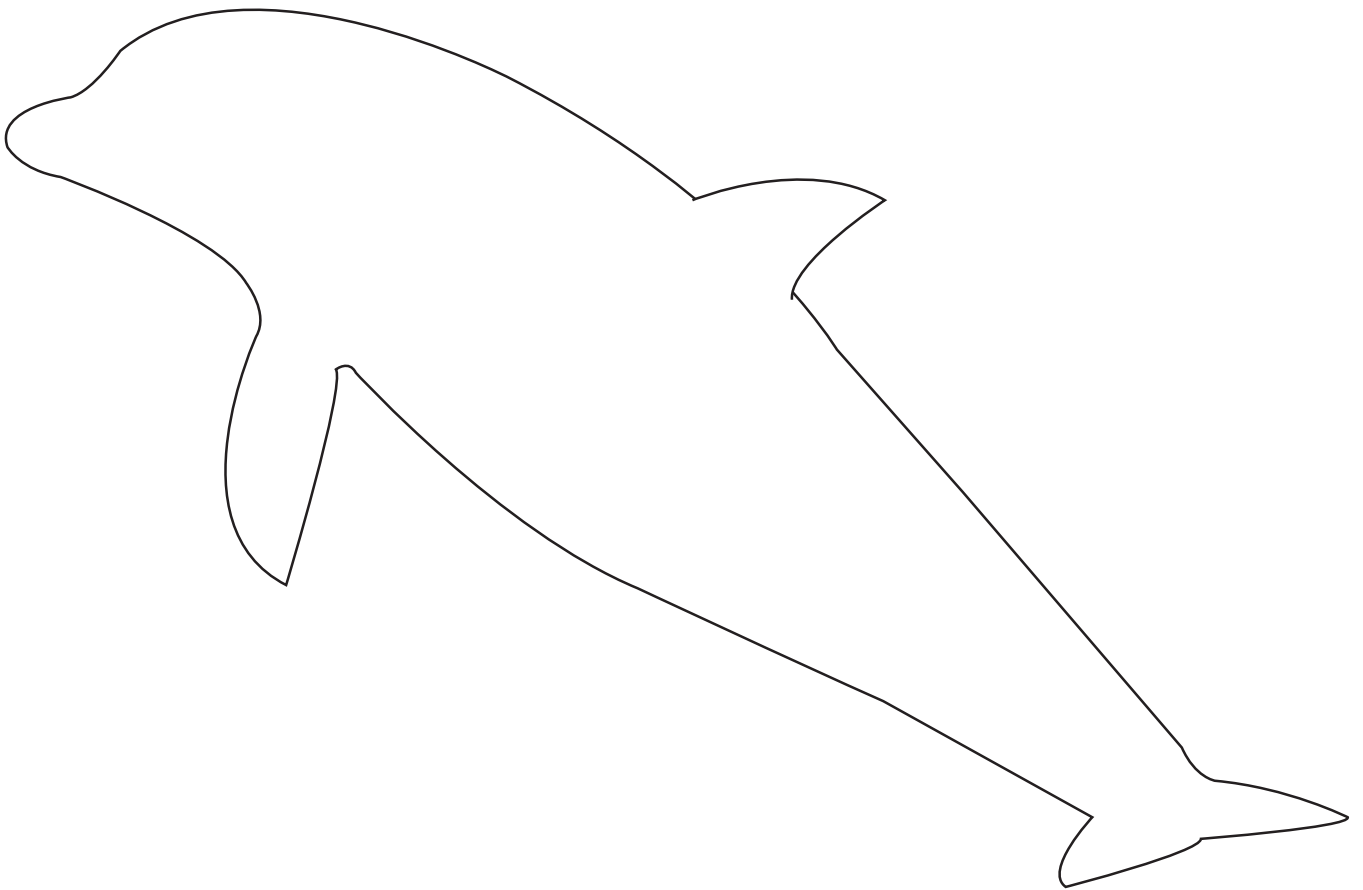
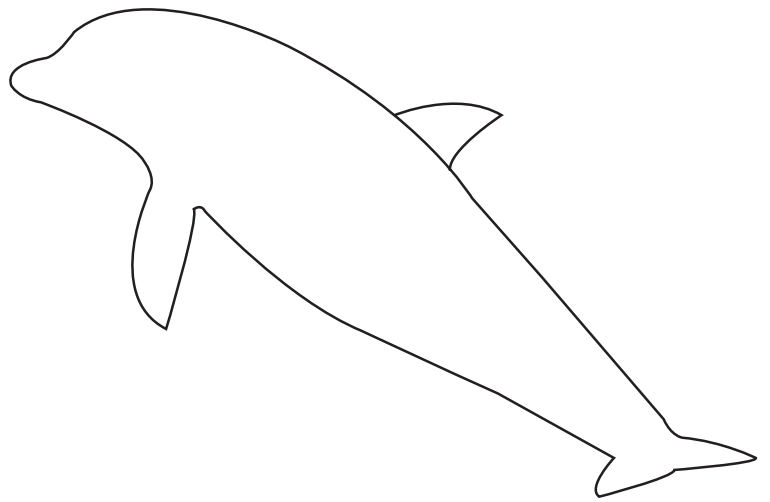





Patterns can also be used to render images from wire.
To experiment with wire art, you can use thin wire hangers.
Just cut off the top of the hanger with wire cutters and
begin bending.
Warning: Please wear safety glasses when cutting wire.

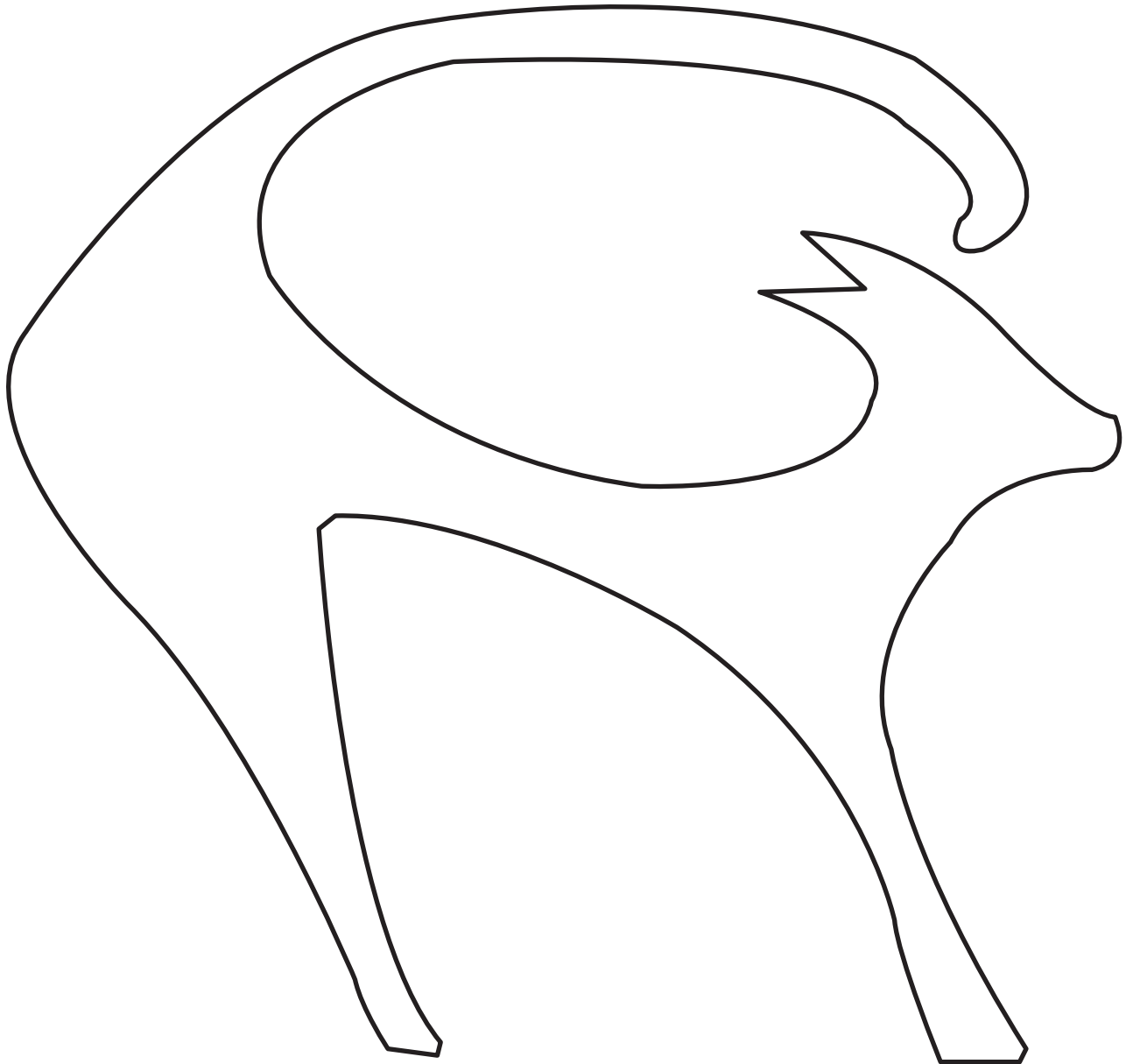

Stamps can be made from patterns using unwanted mouse pads or the sheets of foam that can be bought at larger craft stores. Synthetic sponges can also be cut into shapes.

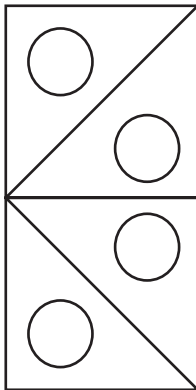
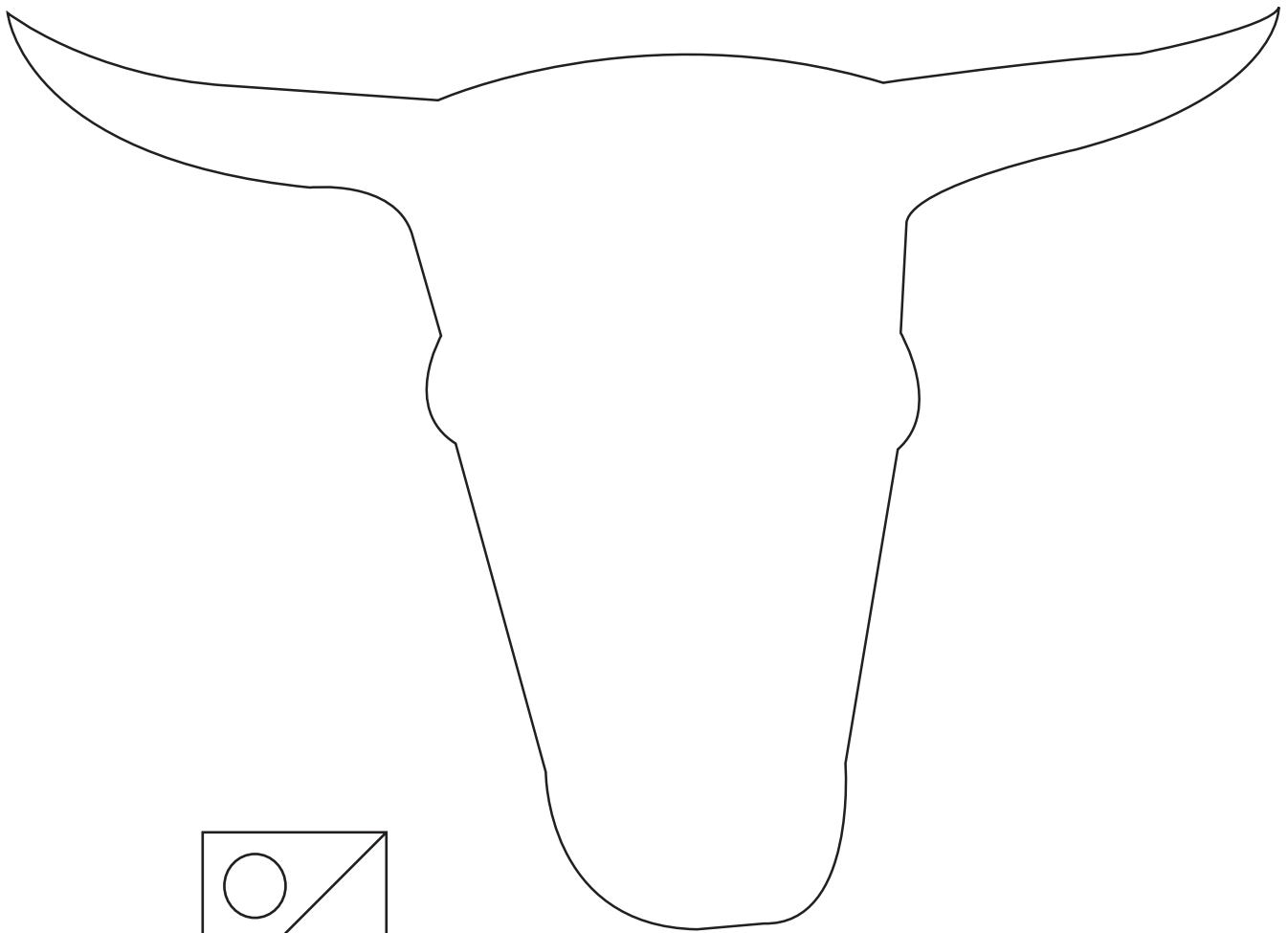

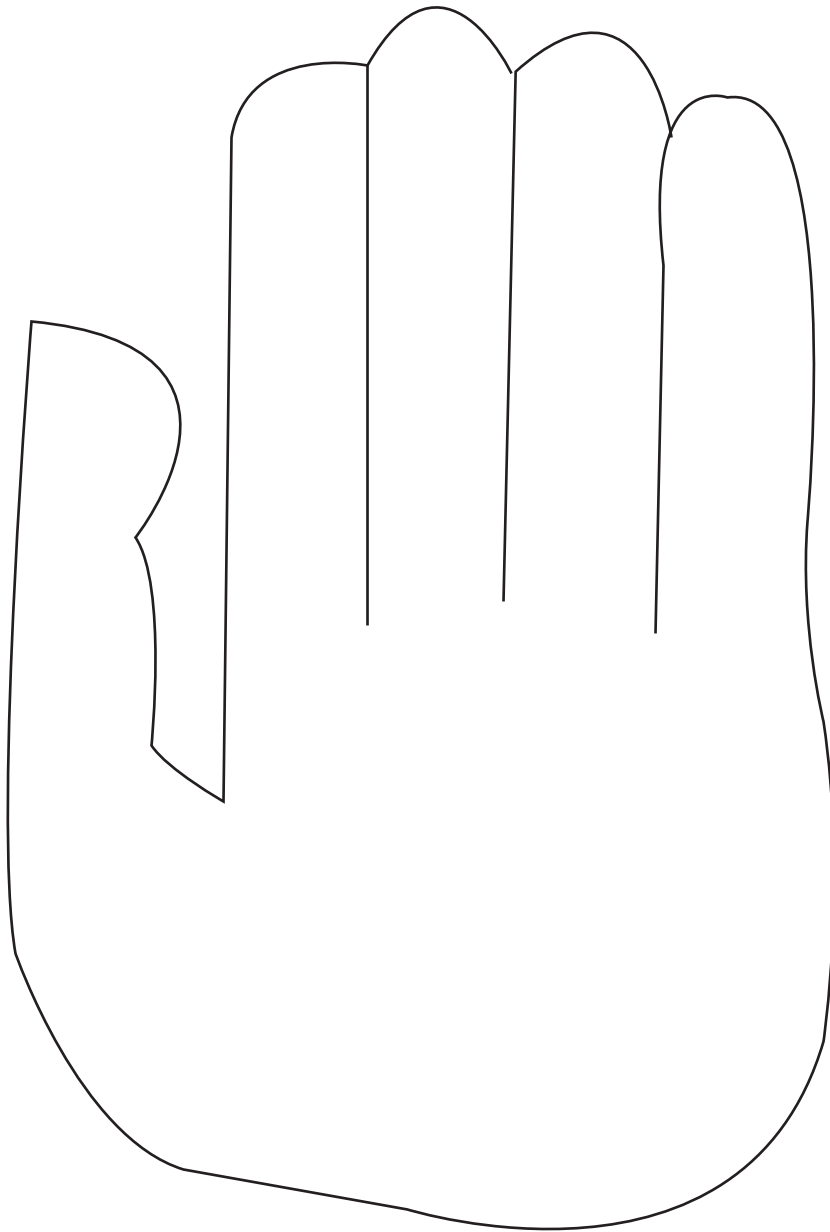
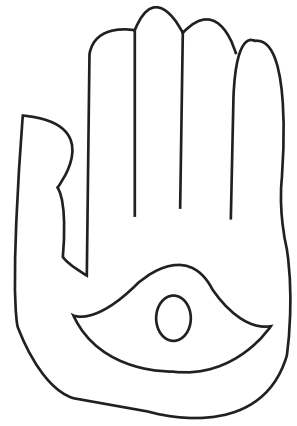
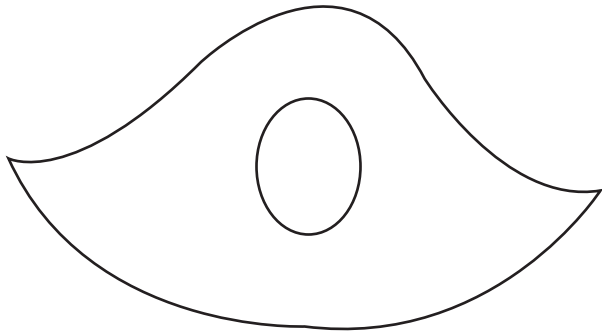

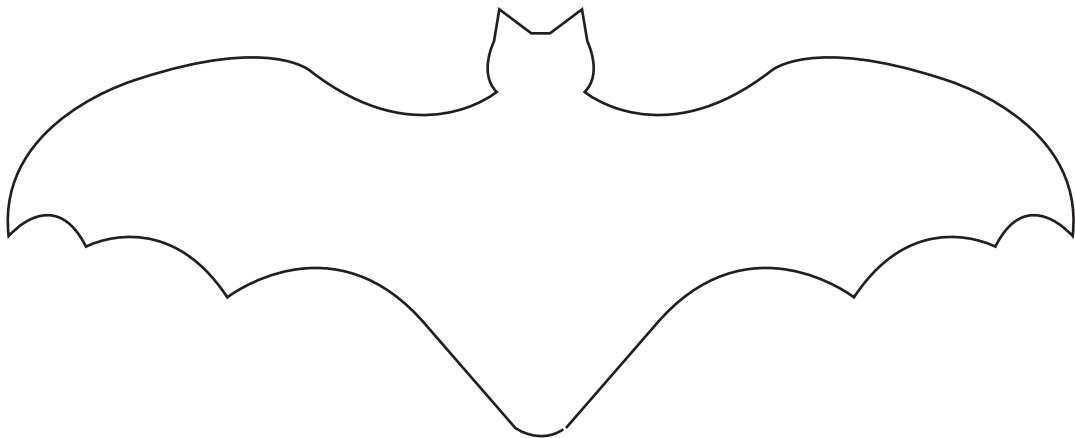
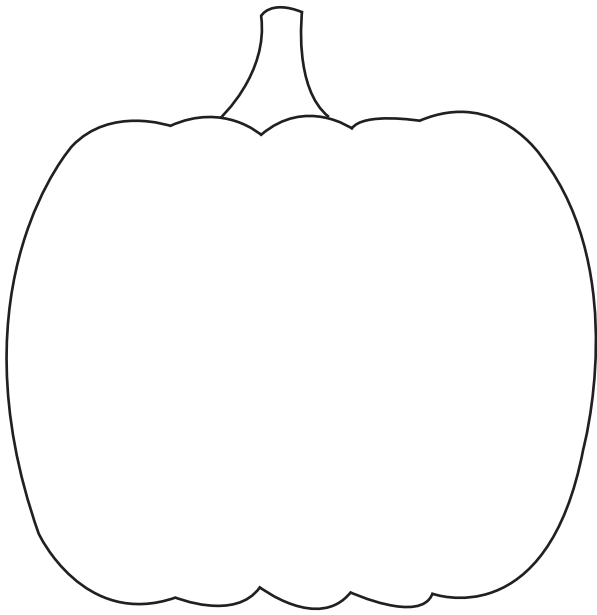
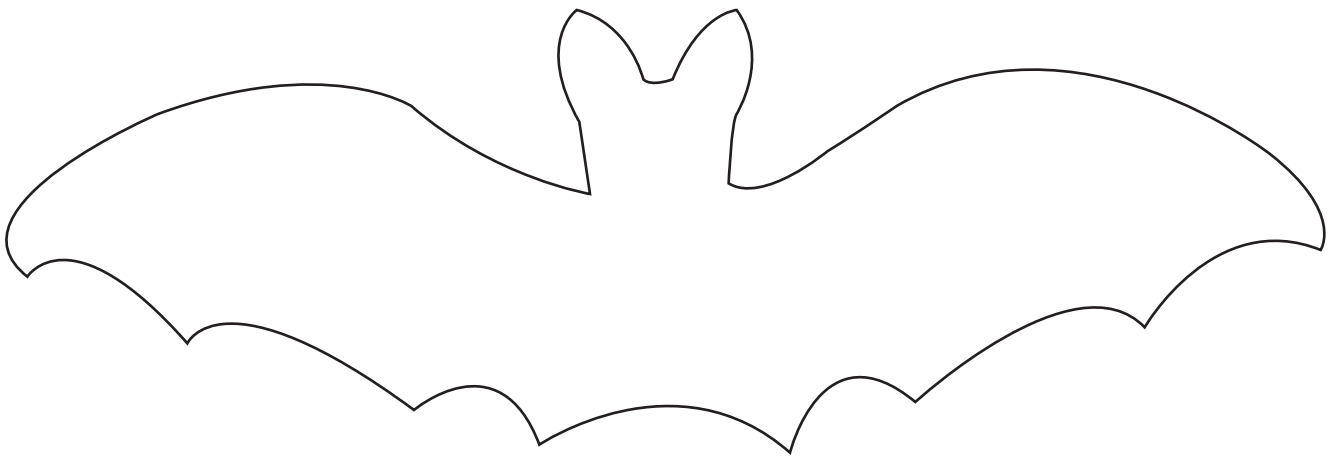

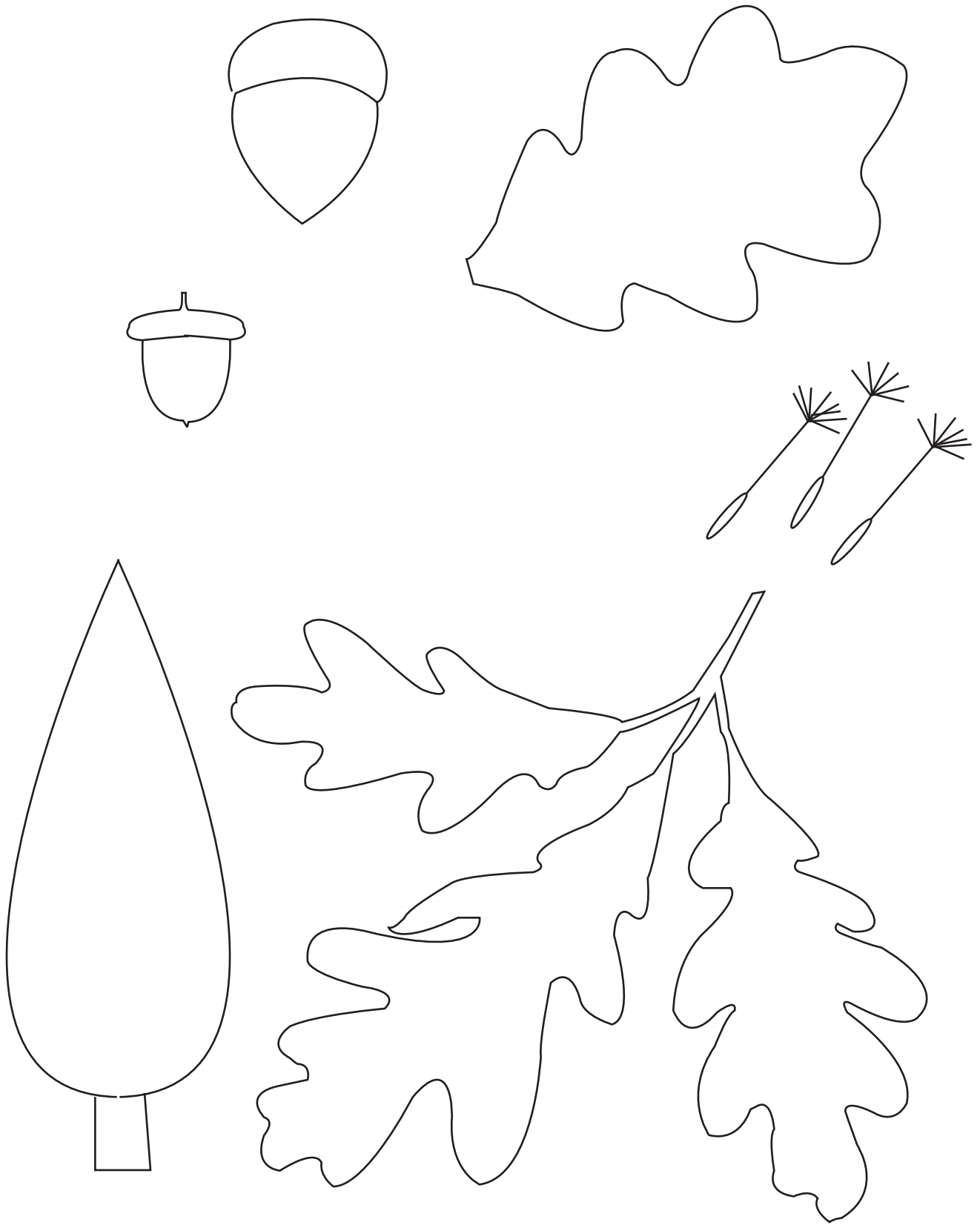

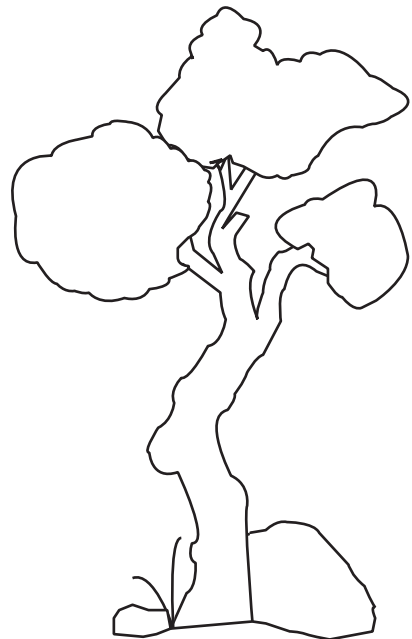
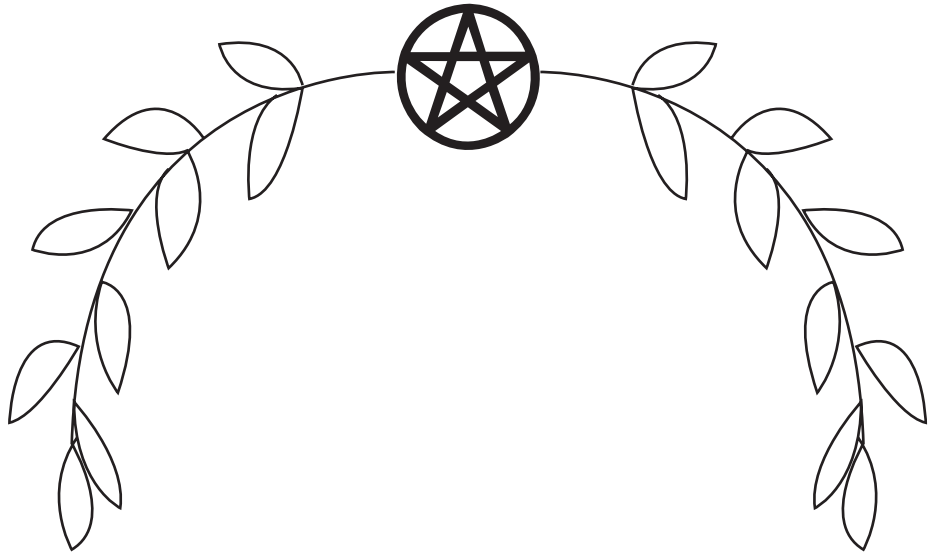
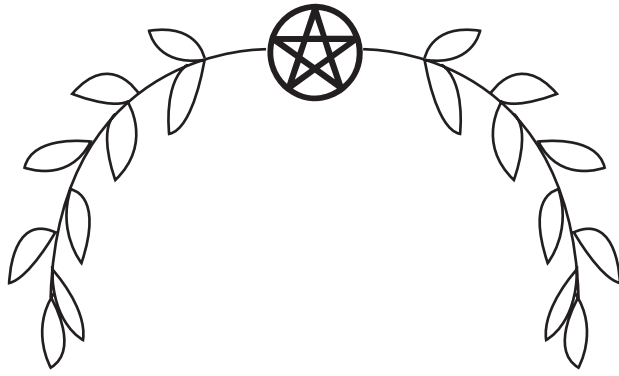
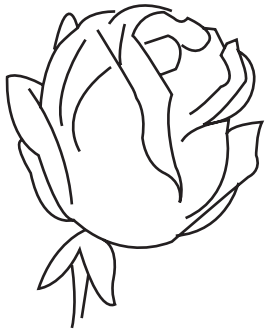

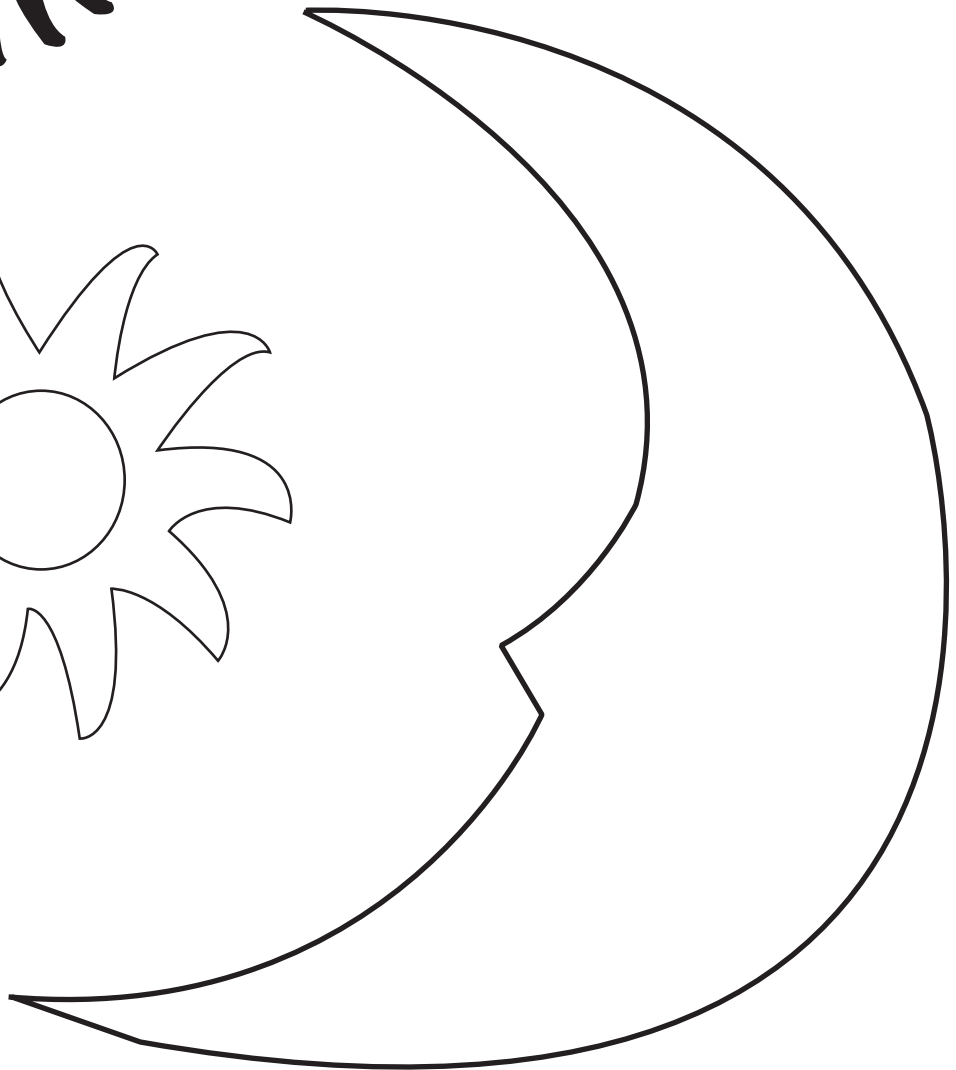
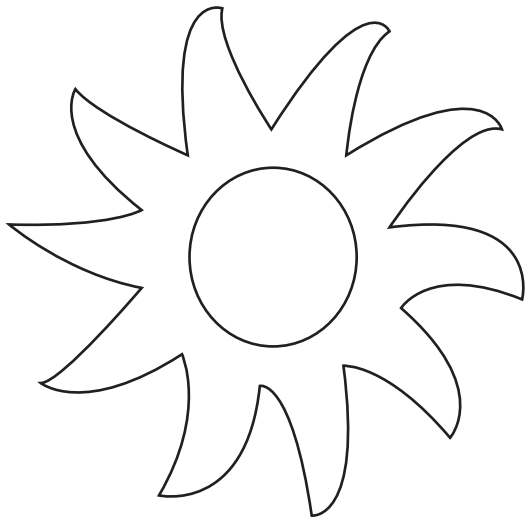
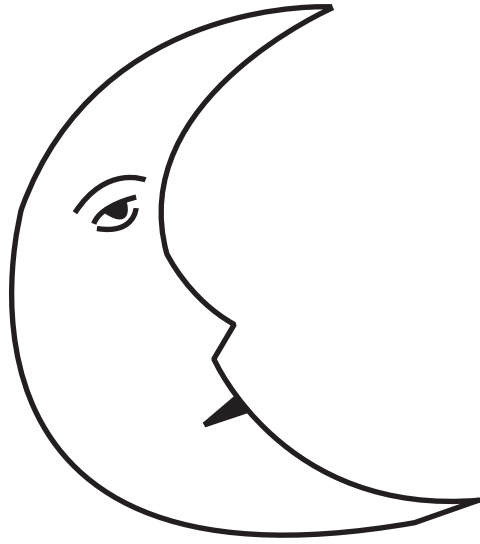
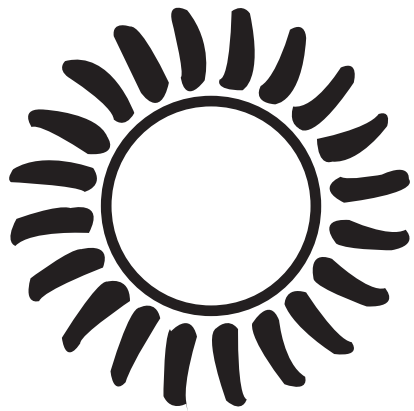

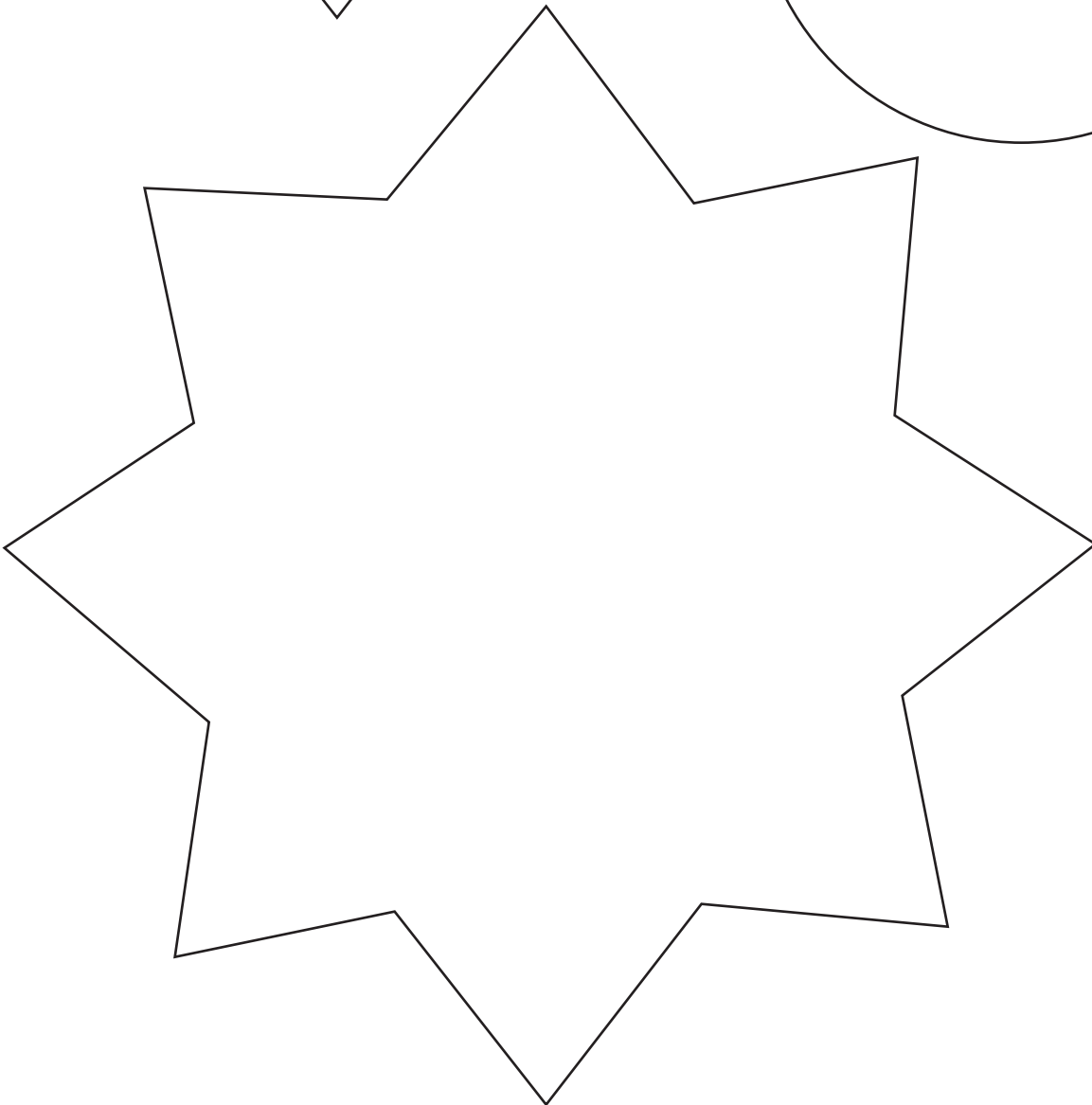
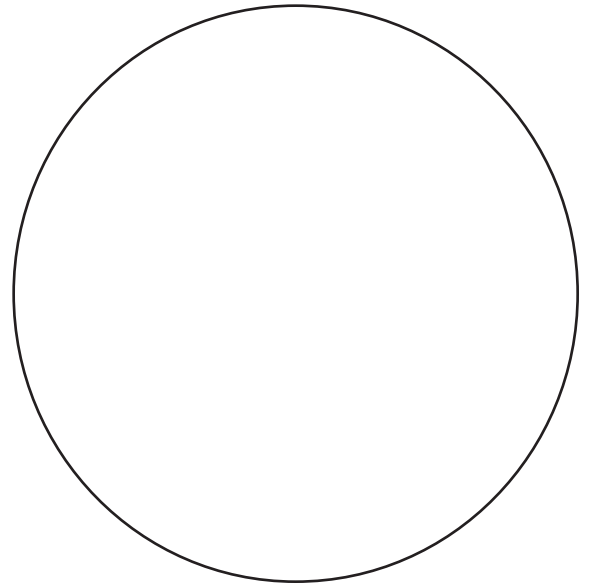
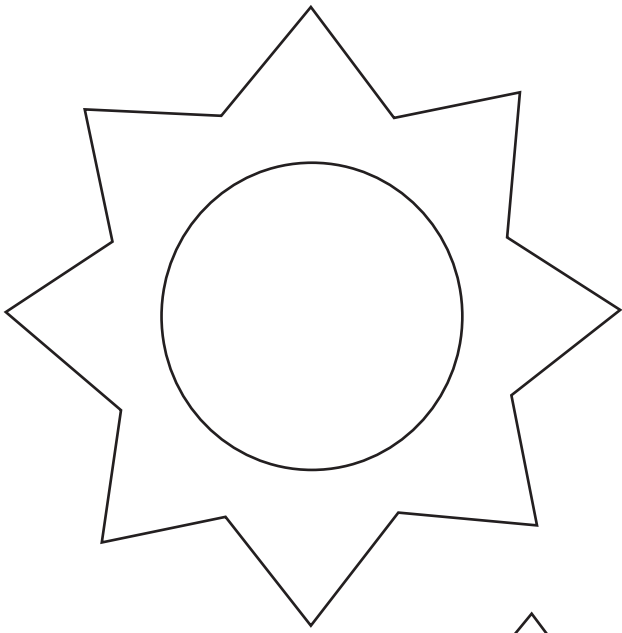

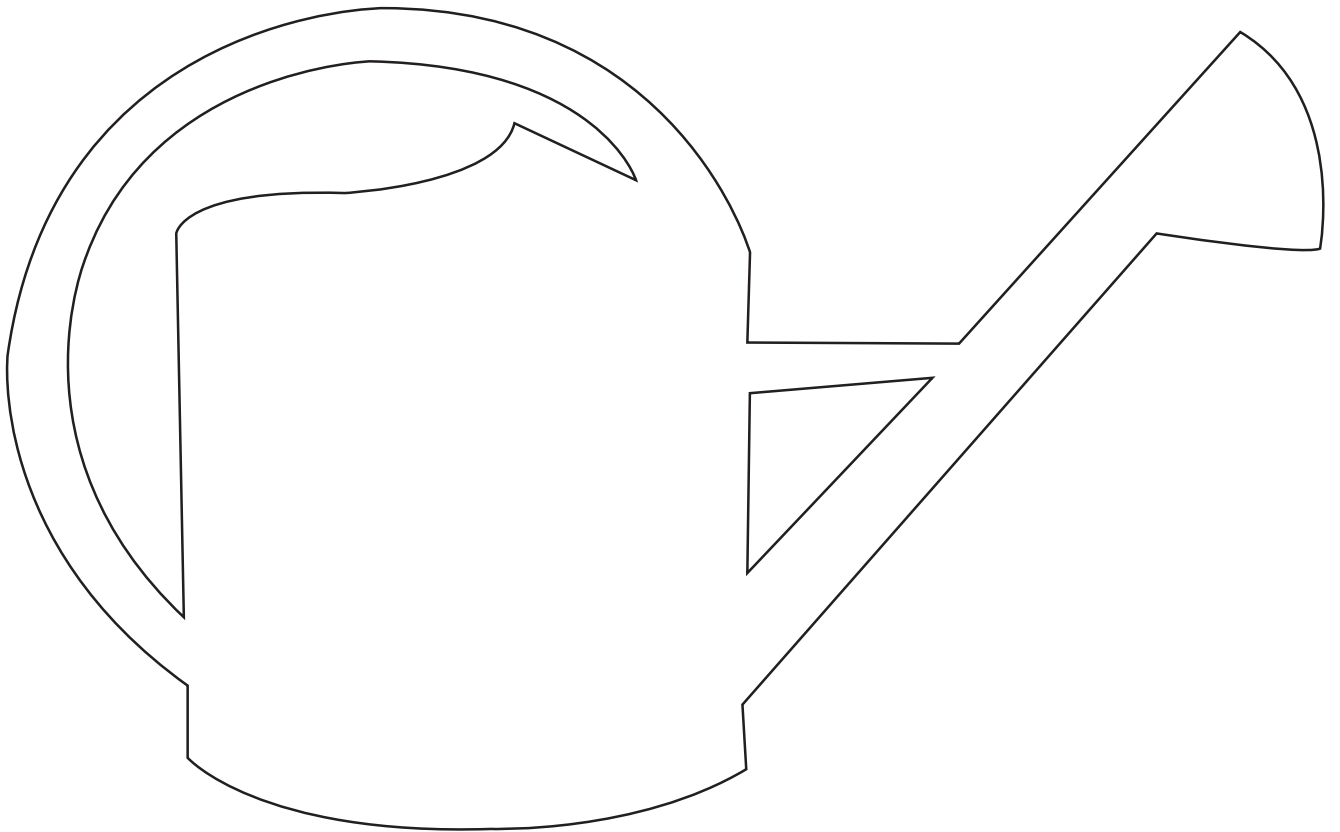
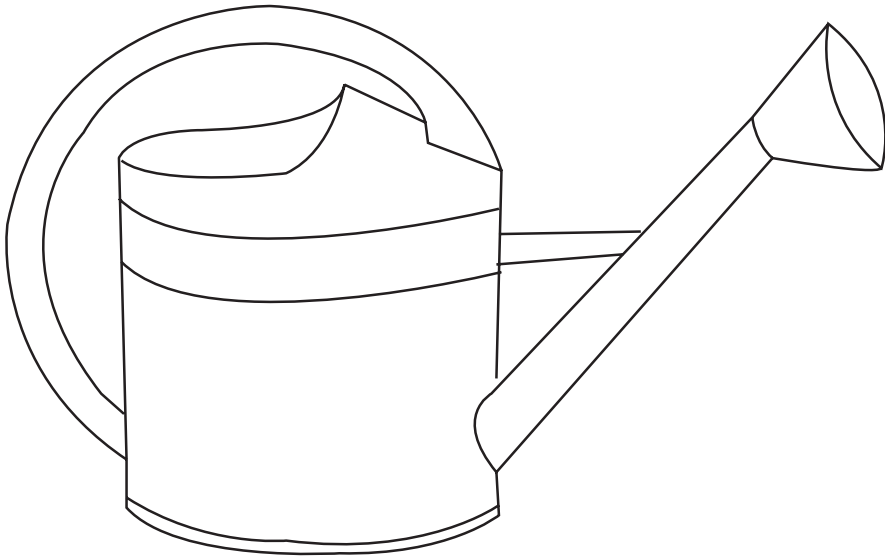

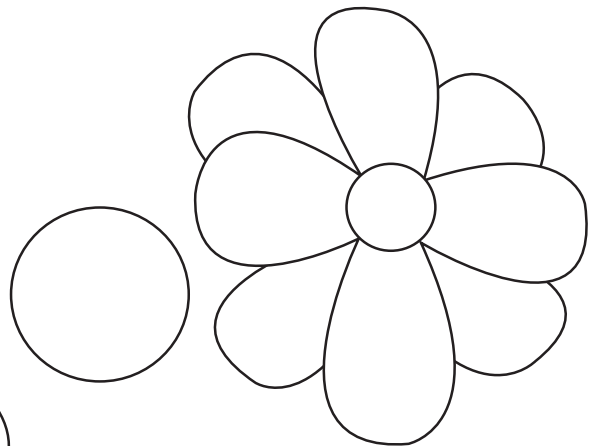
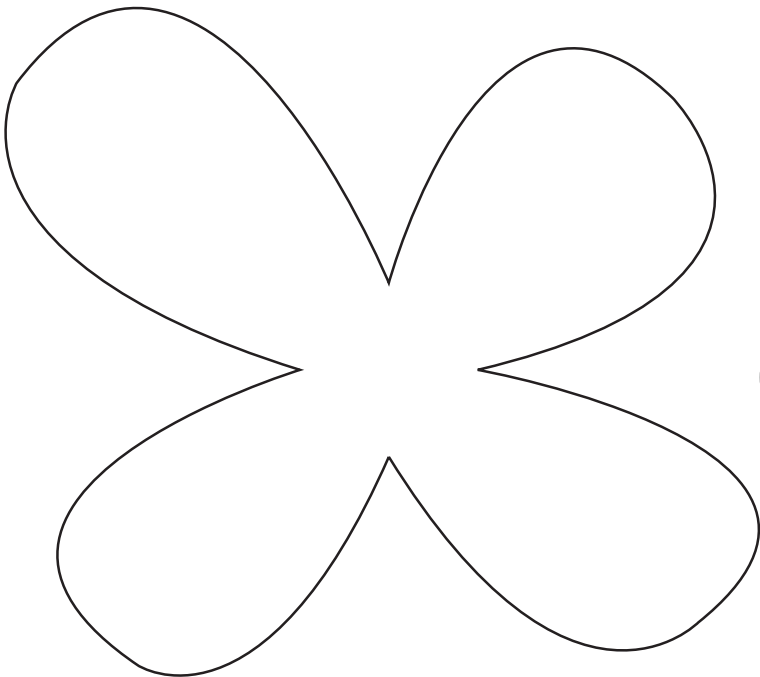
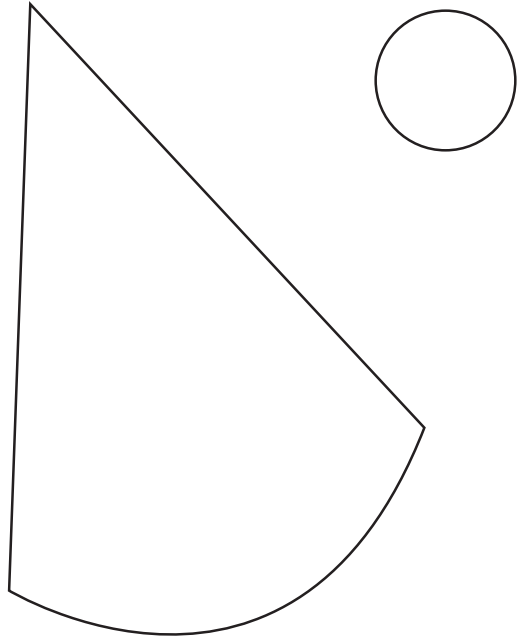
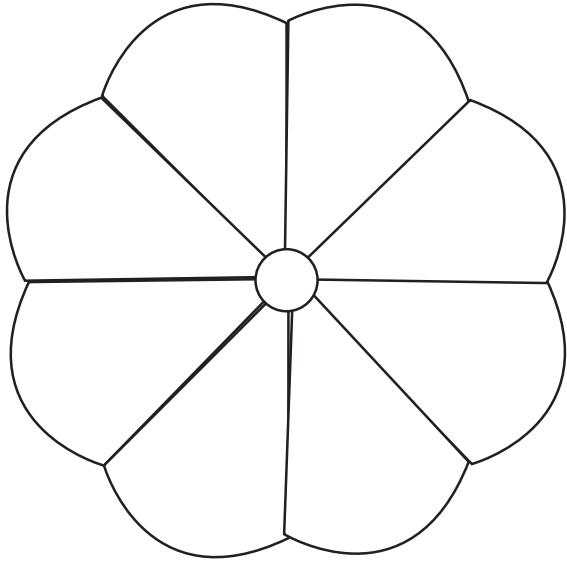

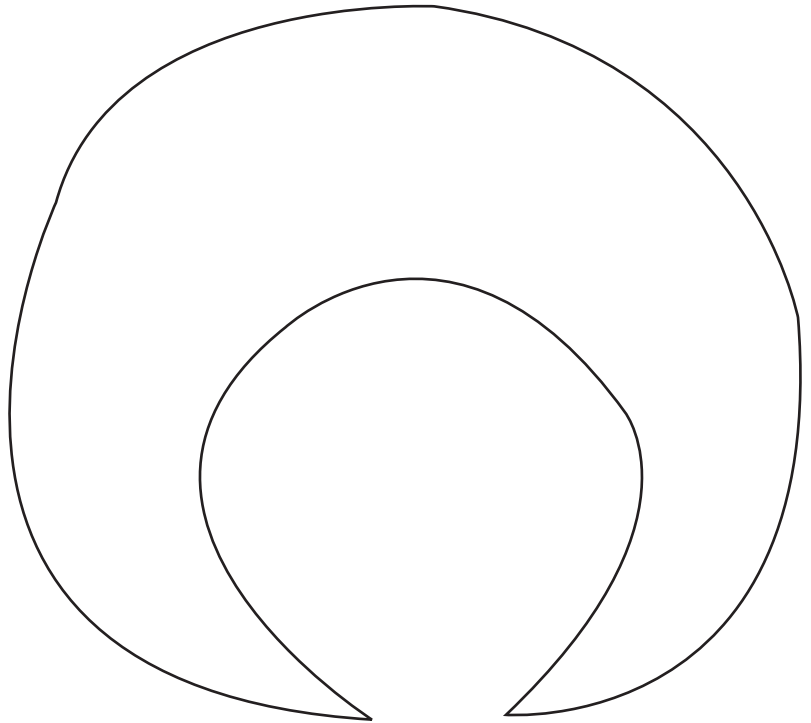
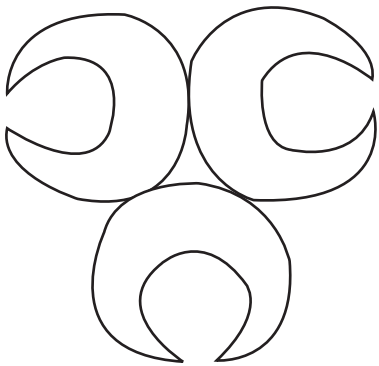
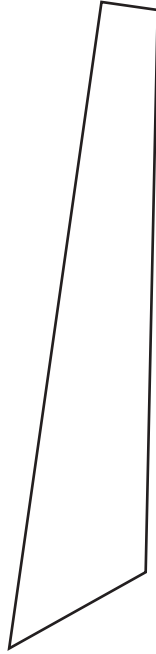
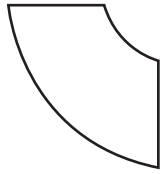
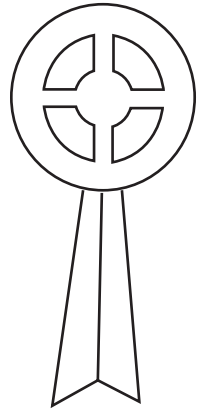
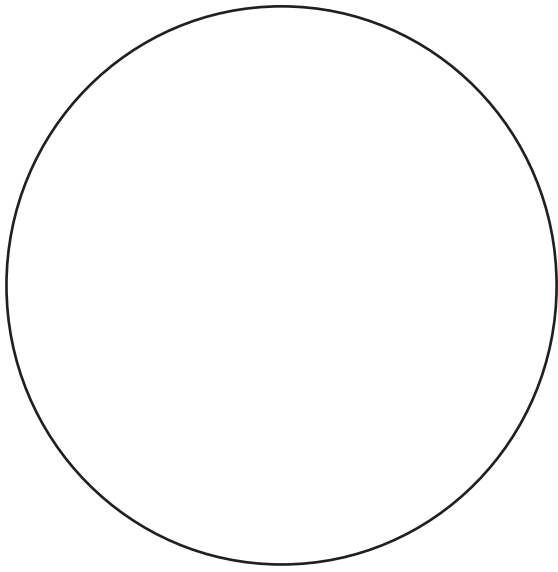

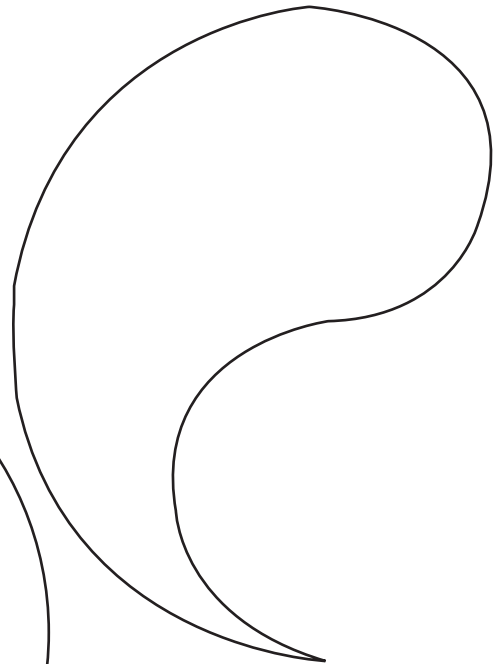
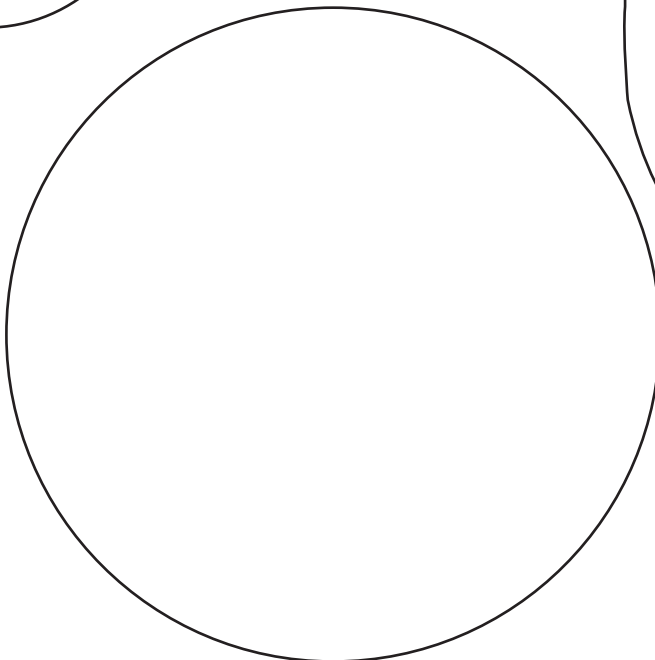
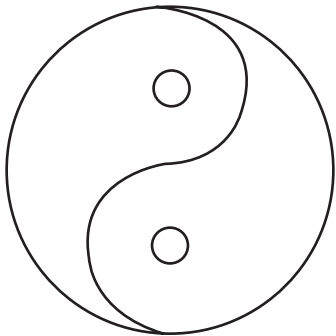
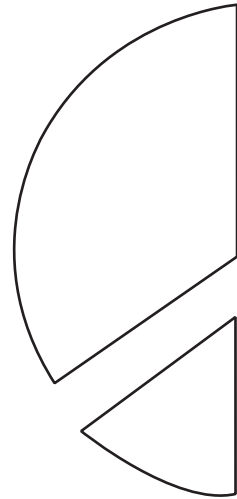
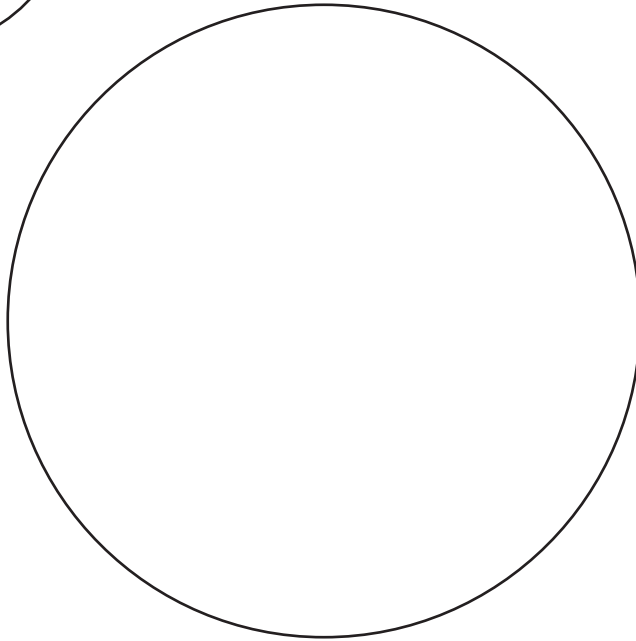

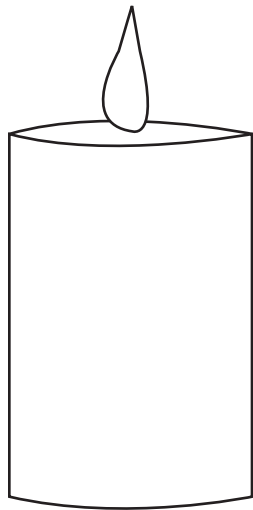
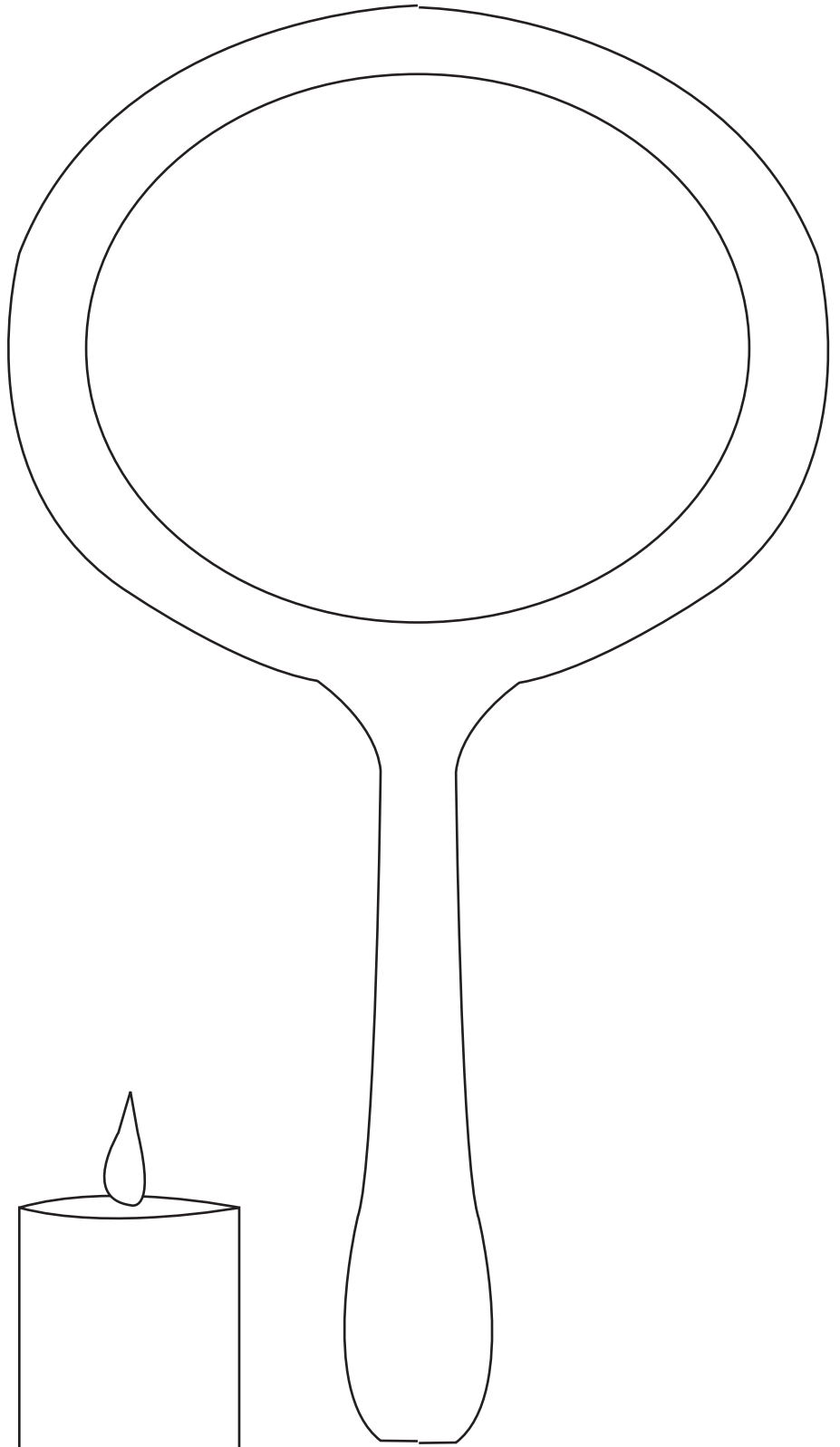
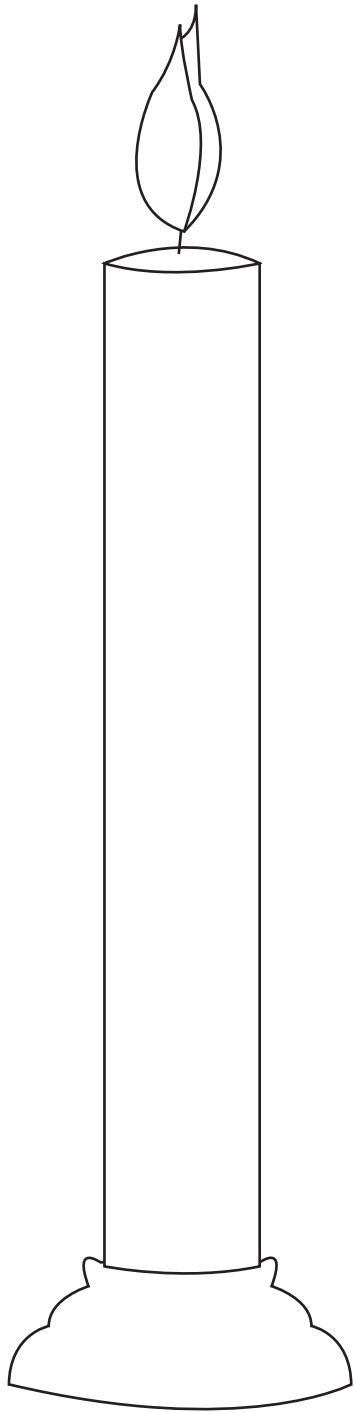

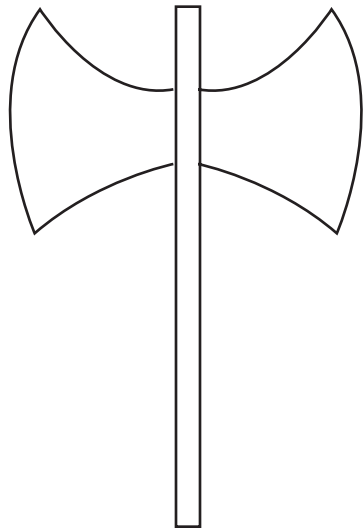
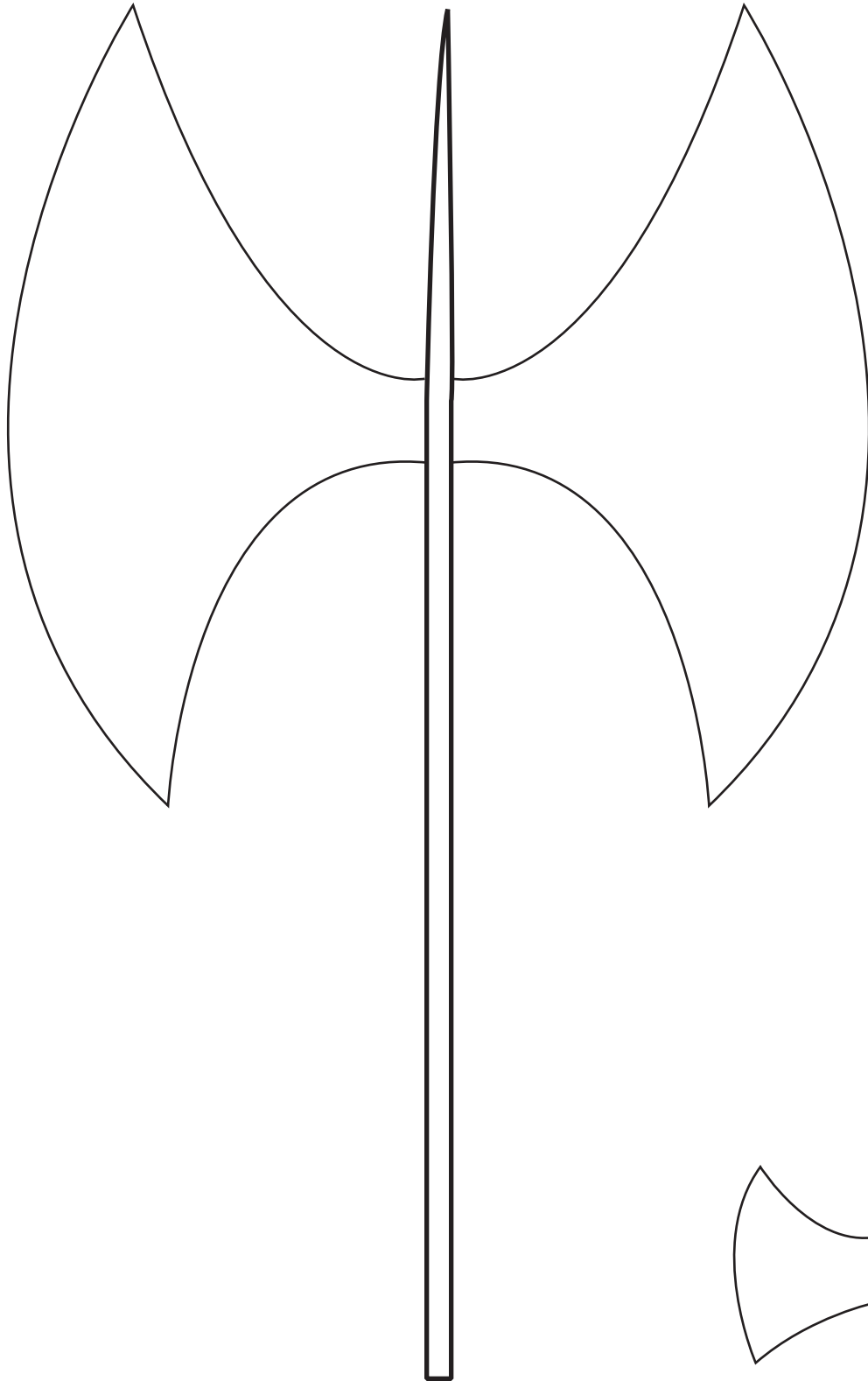

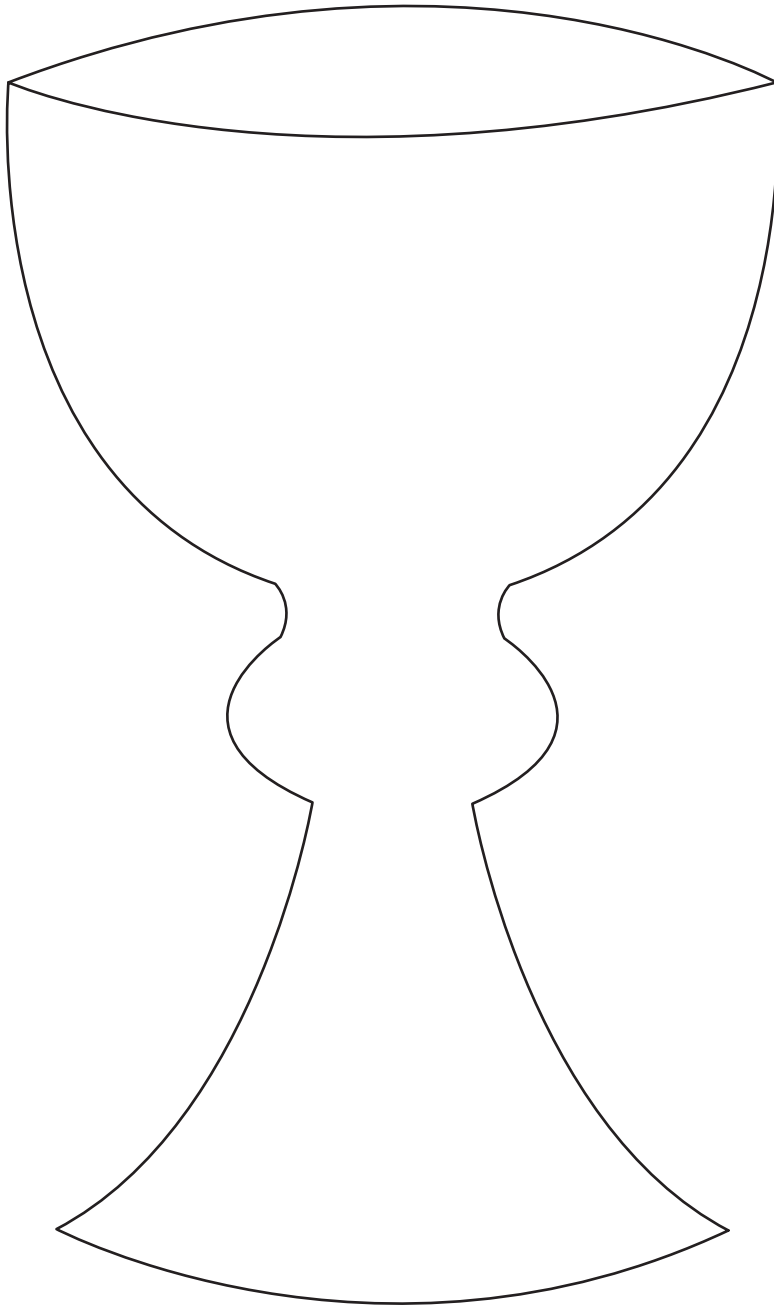

Ways to use these patterns and designs:

- Applique
- Glass Etching
- Painting
- Batik
- Wood Burning
- Stenciling
- Stamp Making
- Stained Glass
- Clay Figures
- Paper Mache
- Felt Ornaments
- Airbrushing
- Basic mould designs for plaster of paris and candle wax
- Sequins
- Beading
- Fridge Magnets
- Wood Patterns
- Wood Carving
- Lost Wax
- Wire Art
- Scrap Books
- Quilting

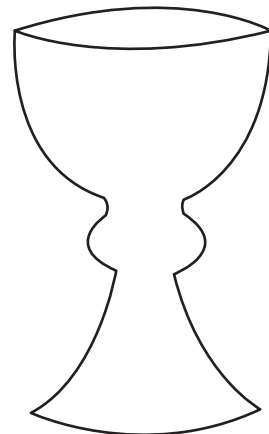

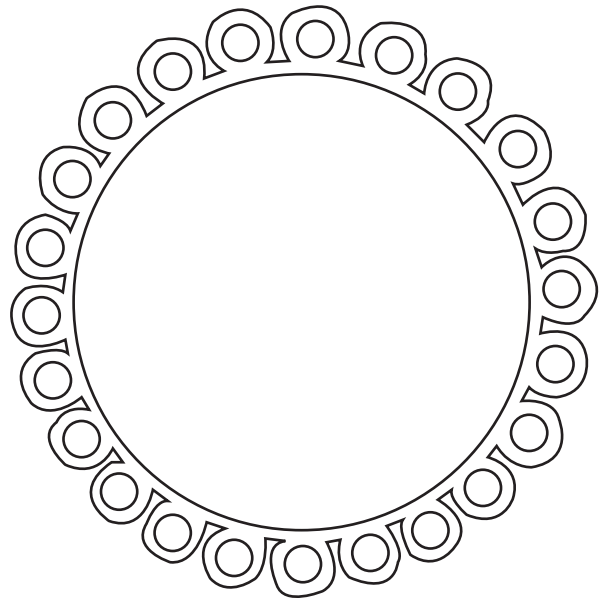
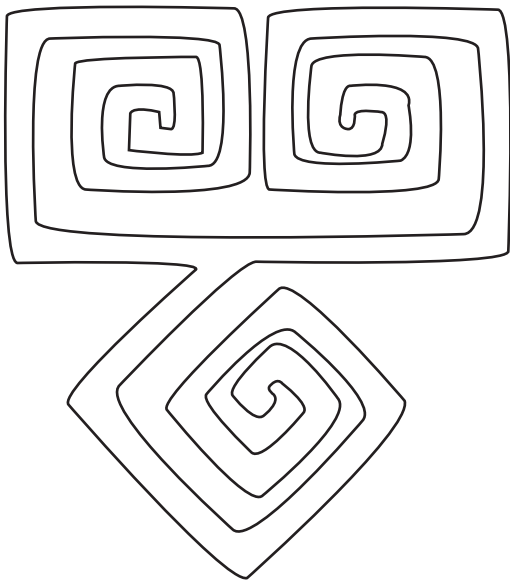
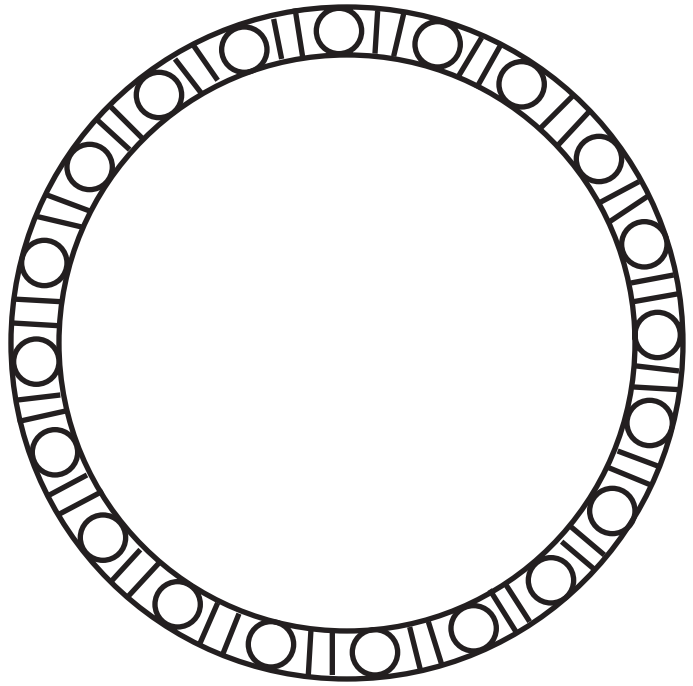
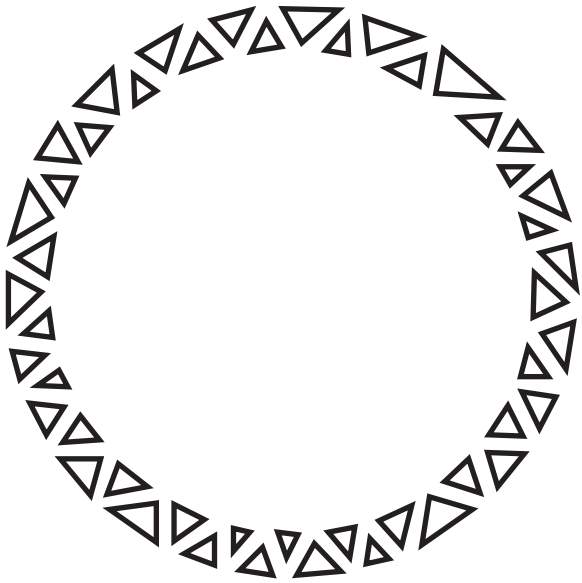
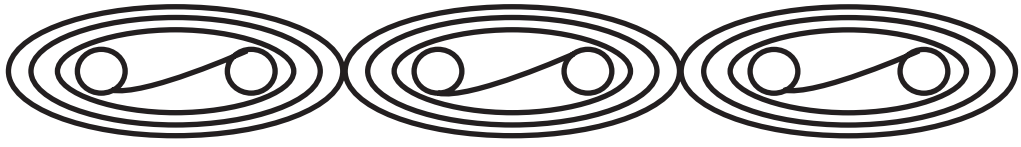

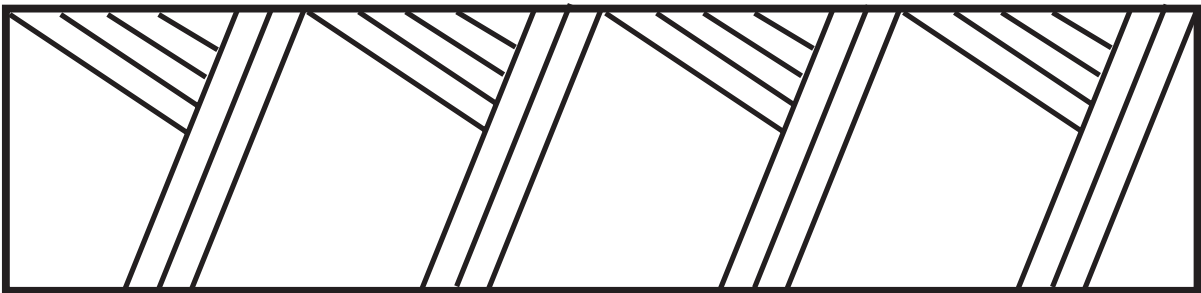
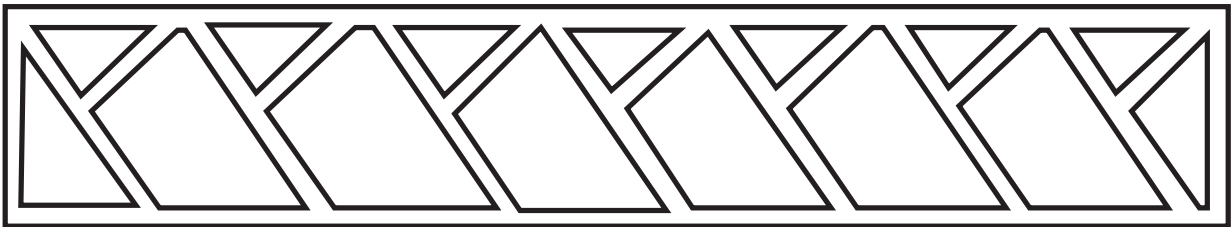
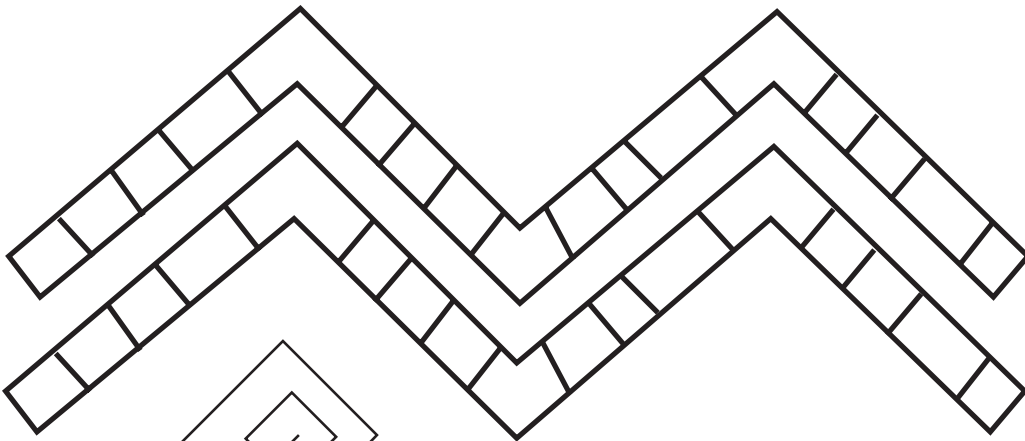
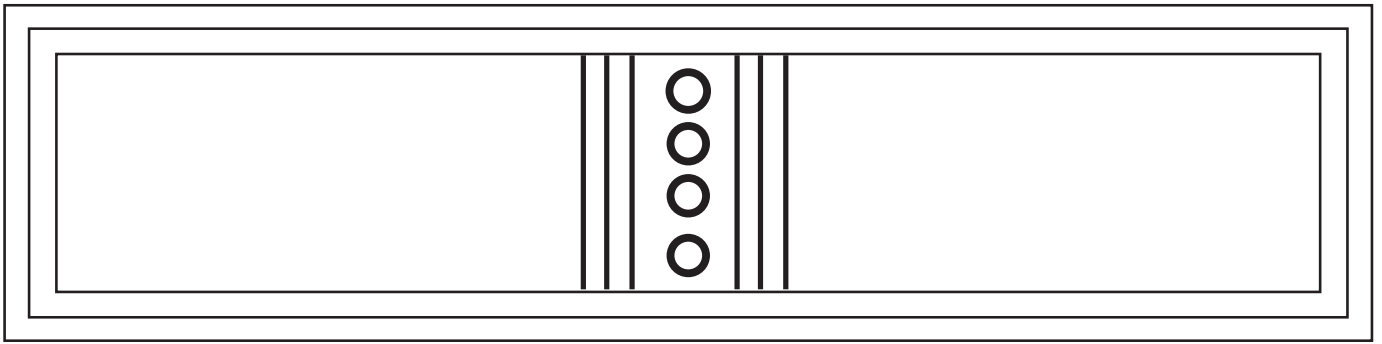

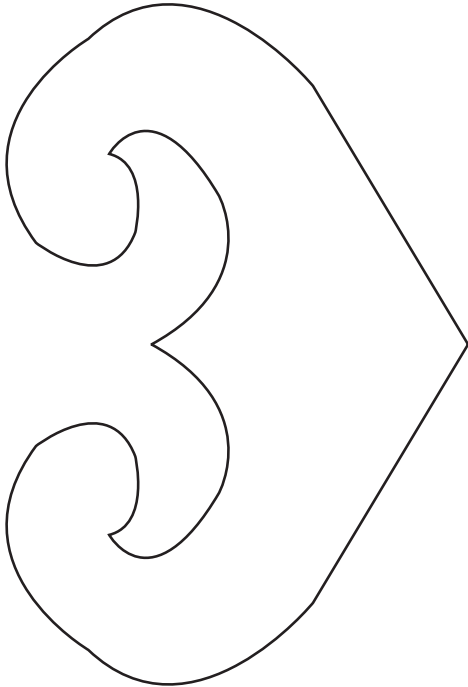
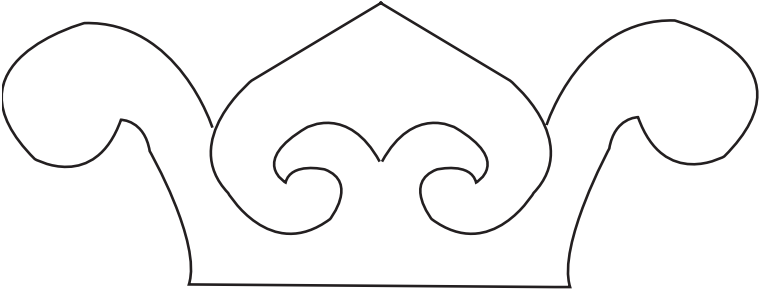
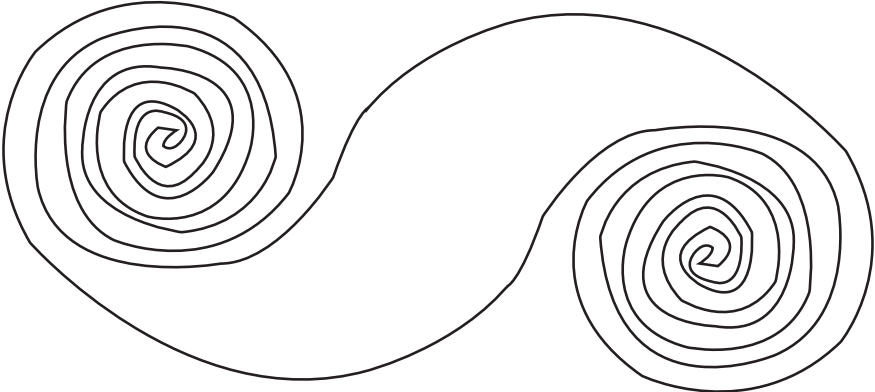
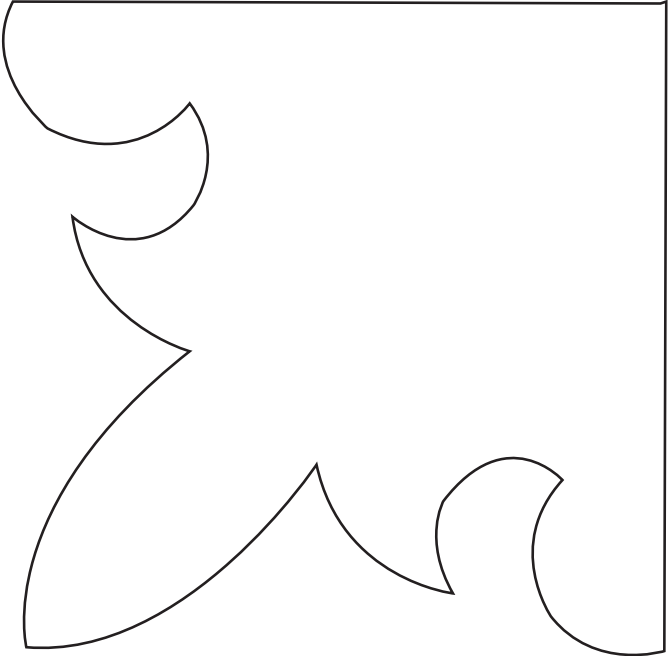
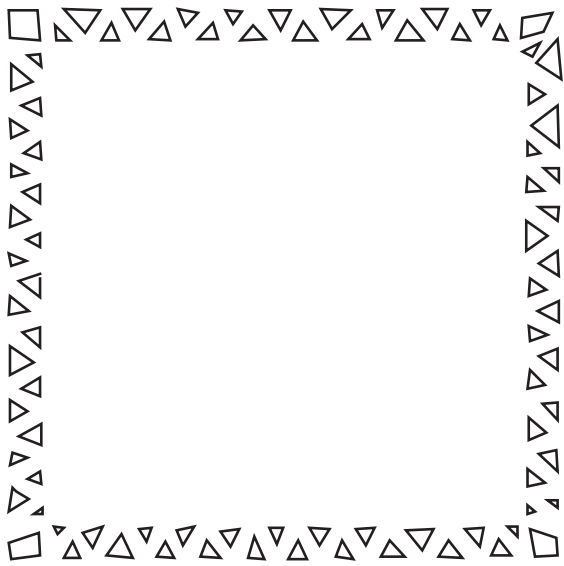

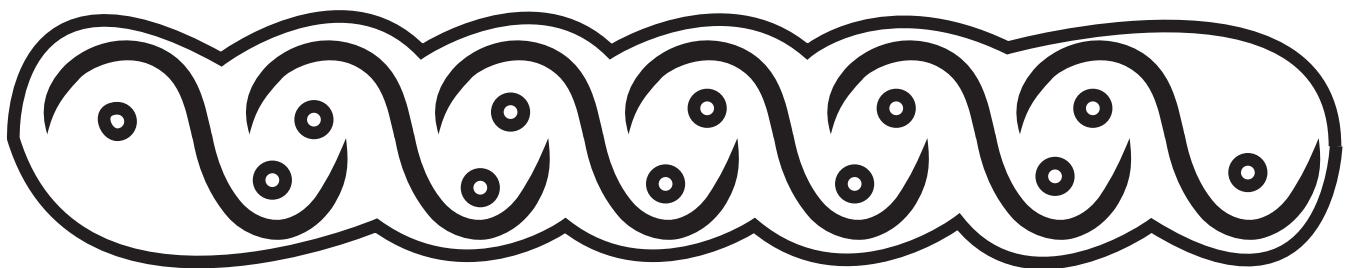
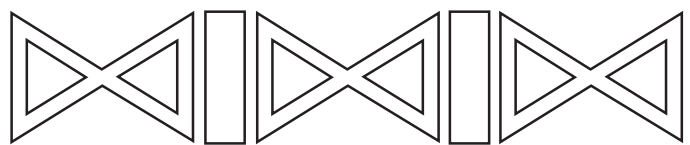
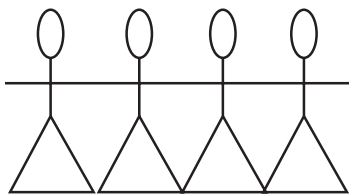
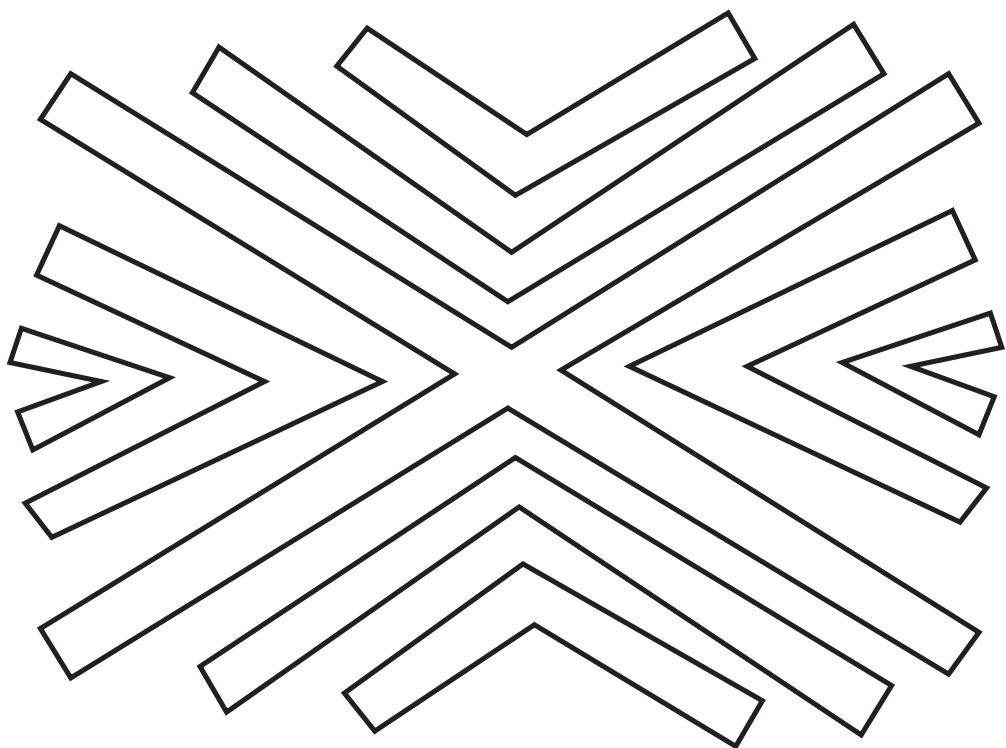
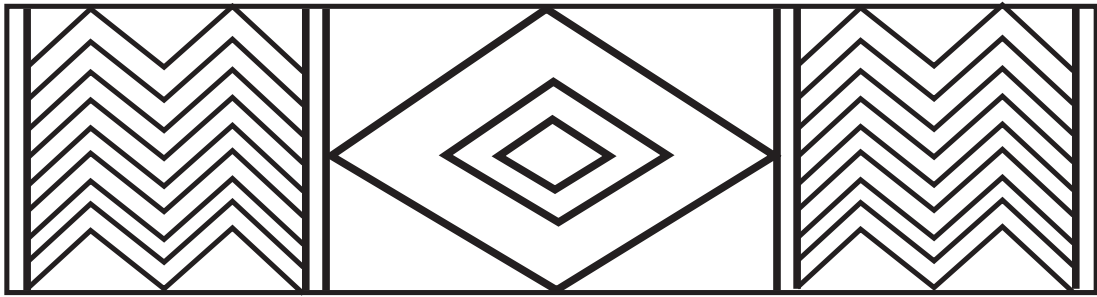

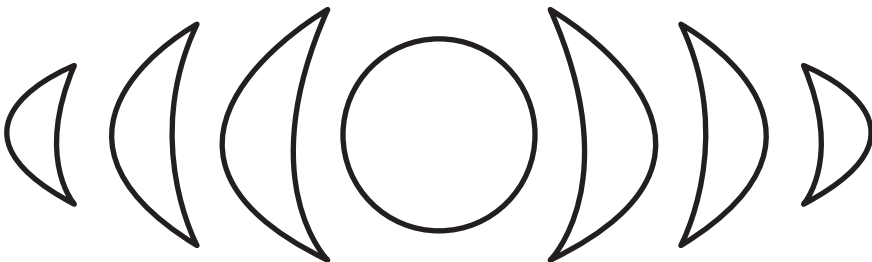
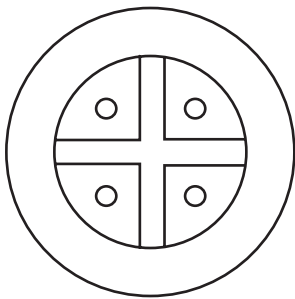
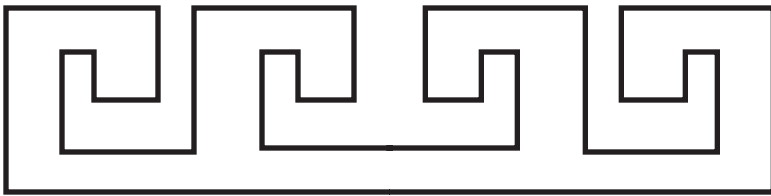
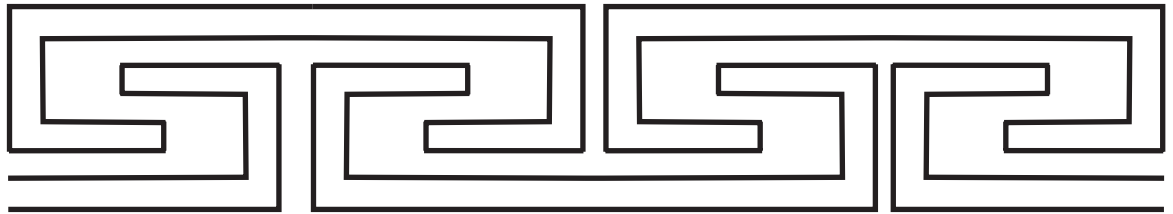
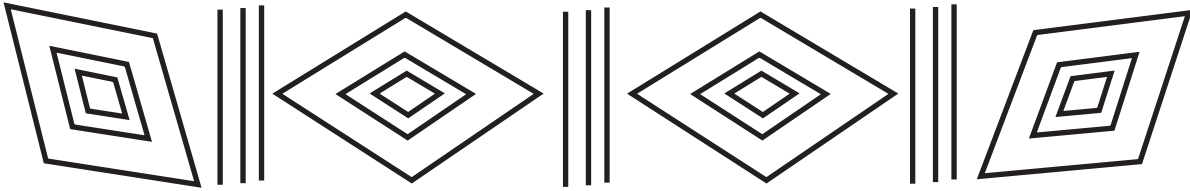

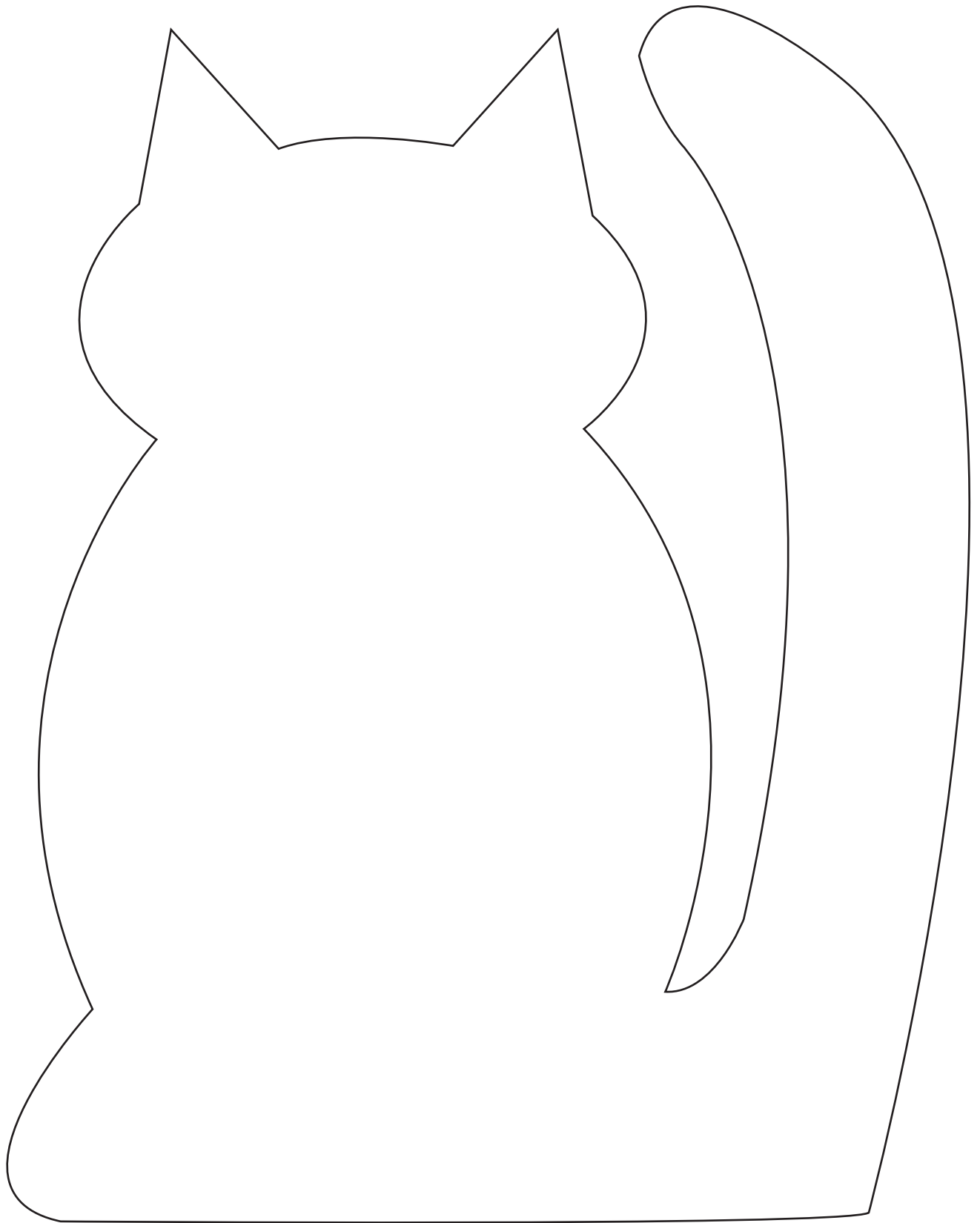

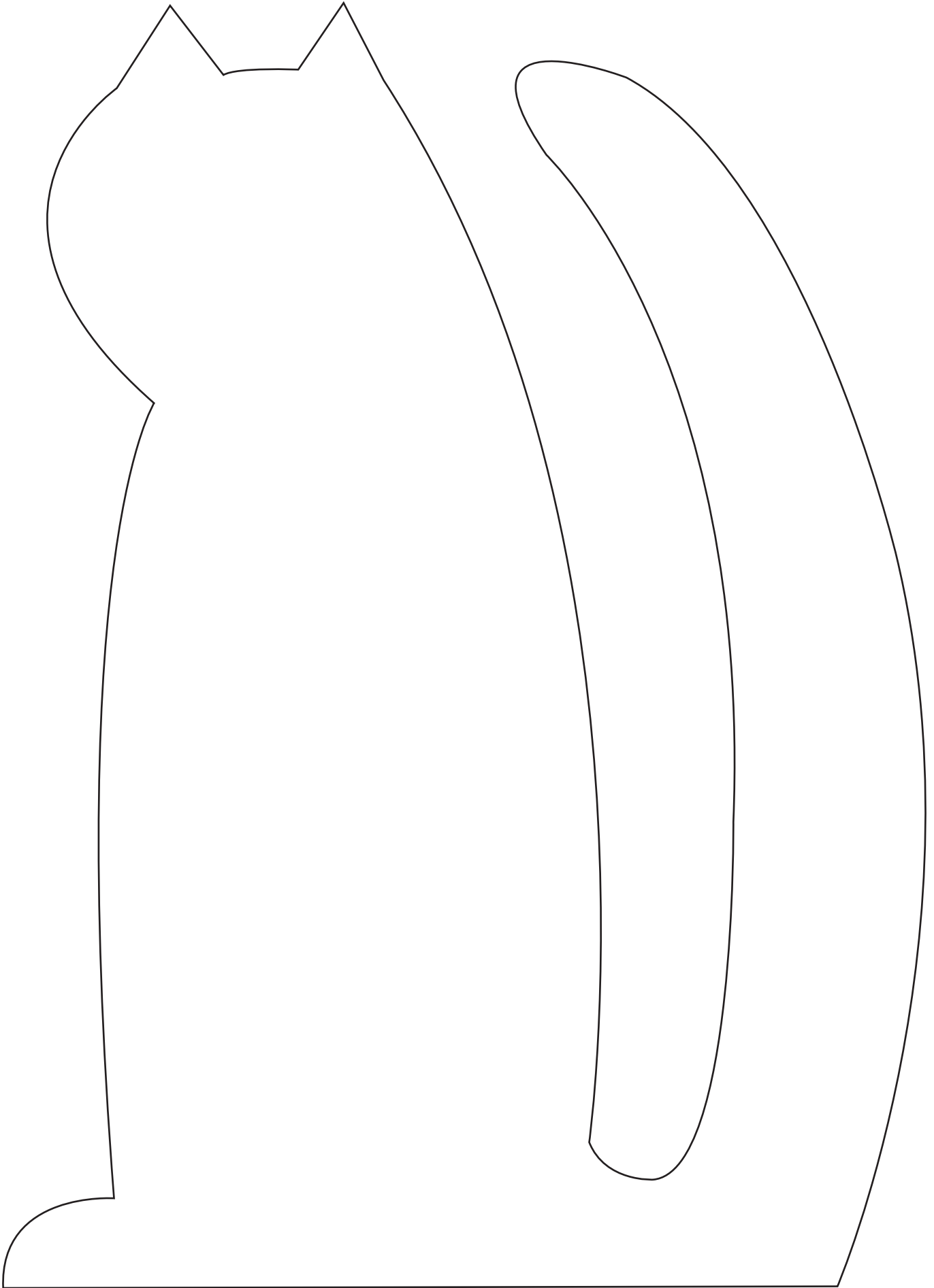

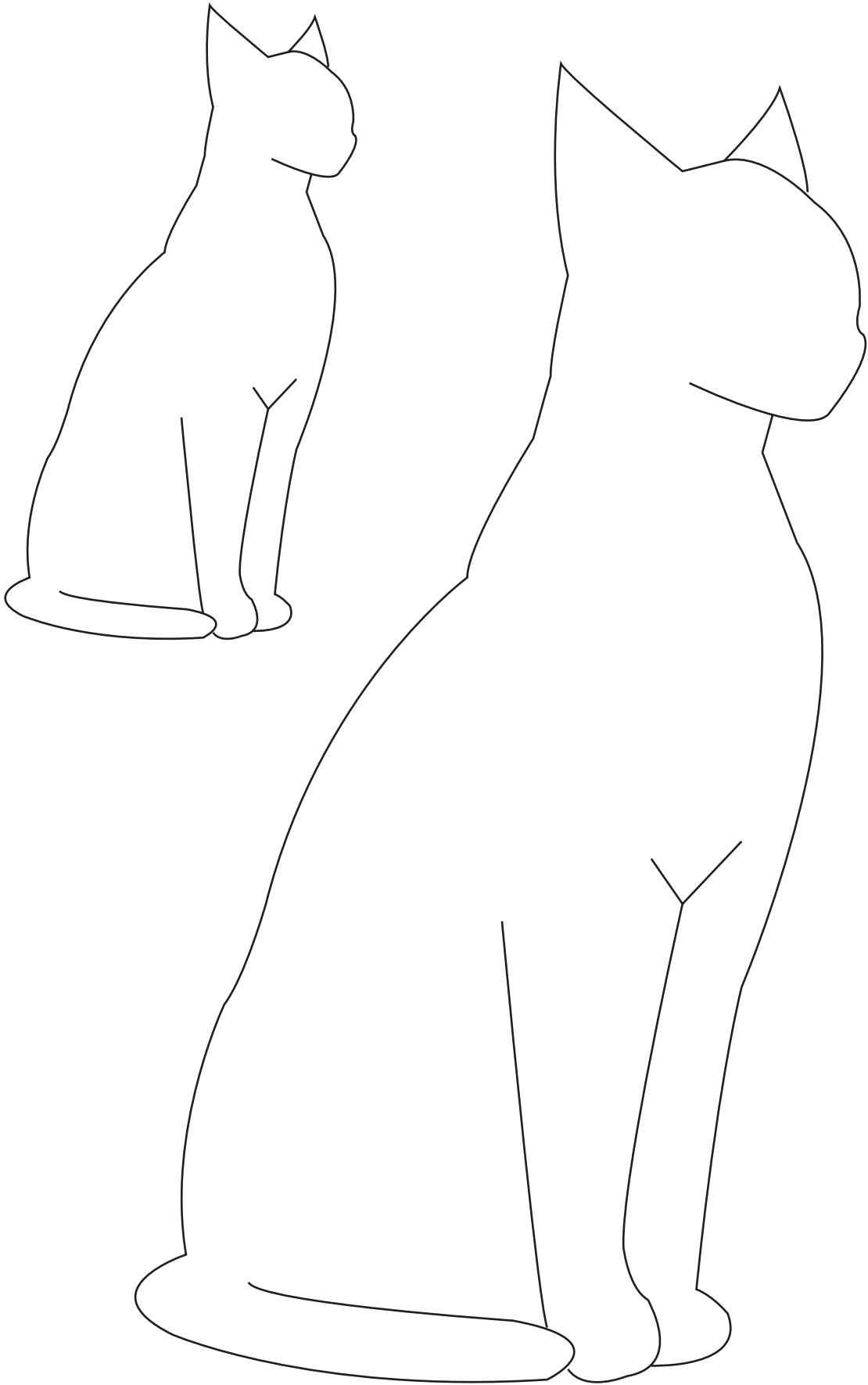

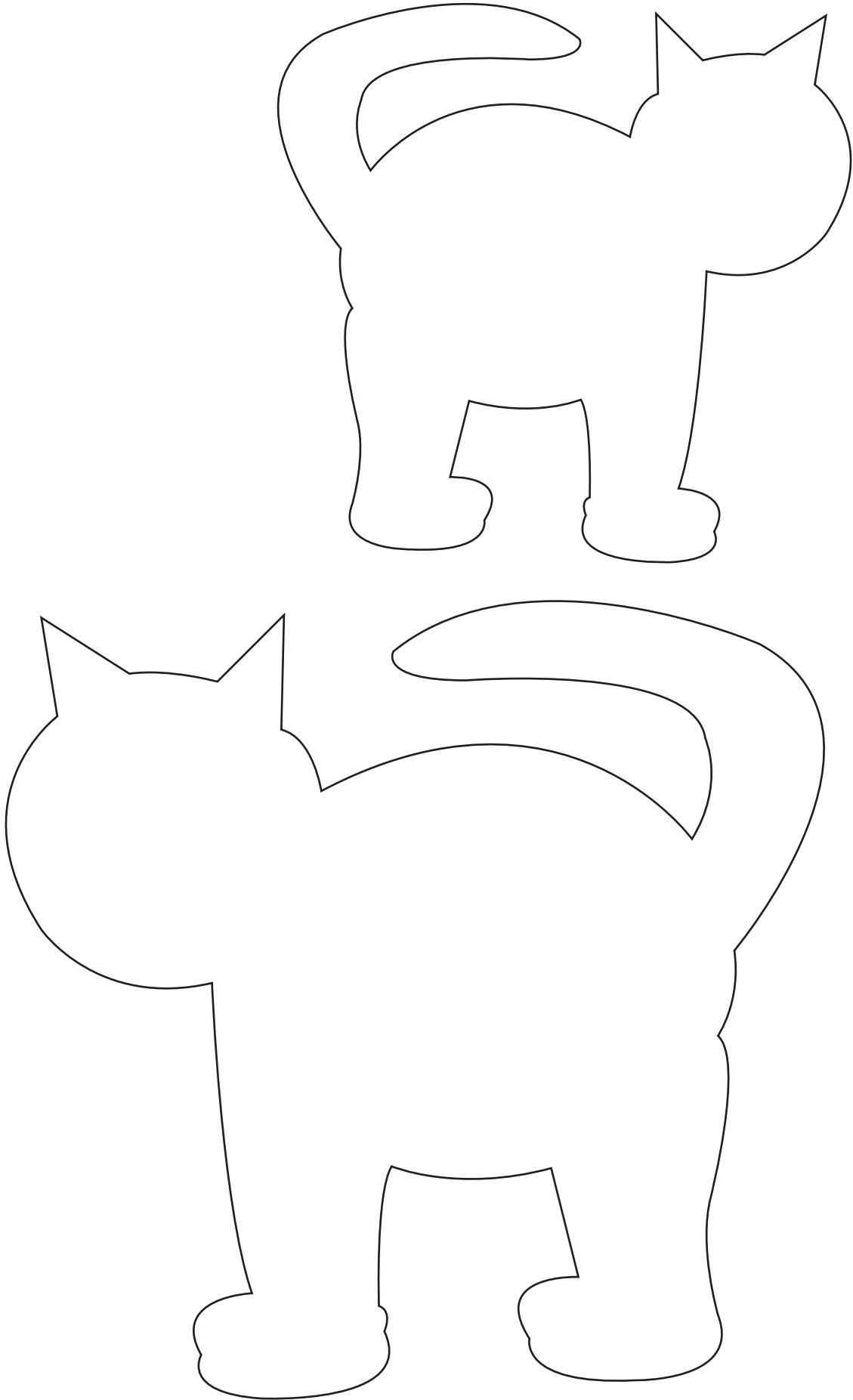

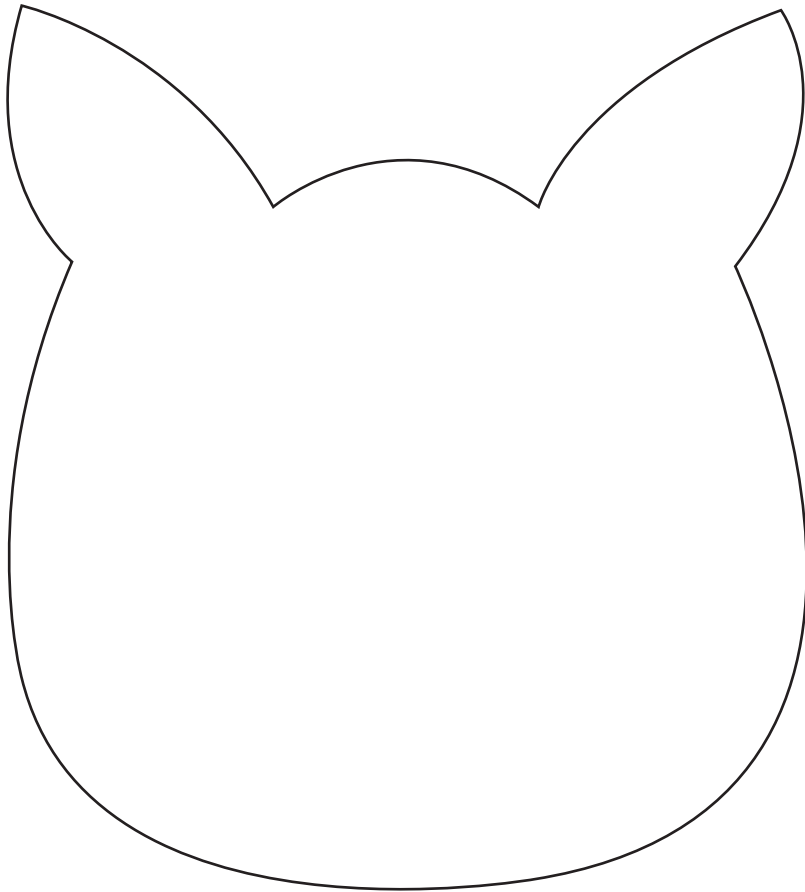
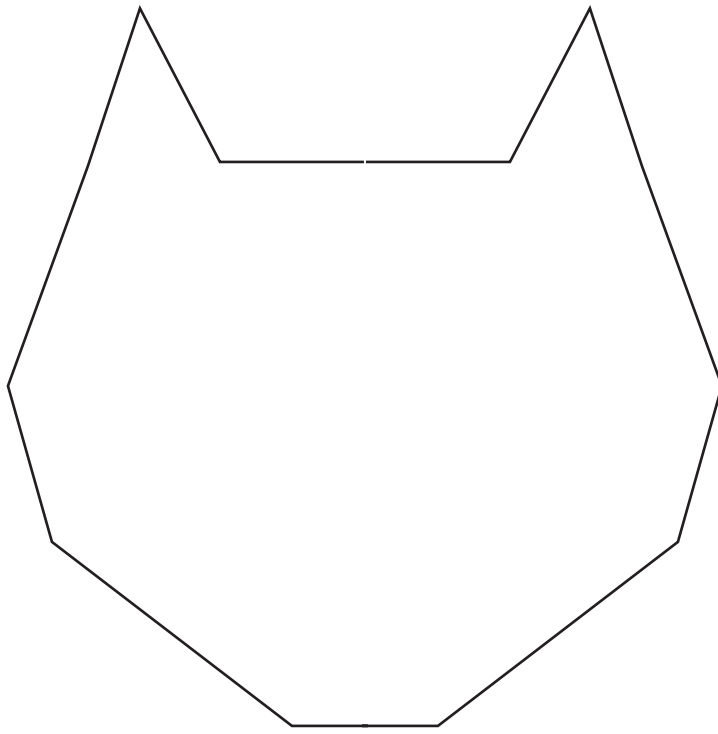

Celestial Scripture

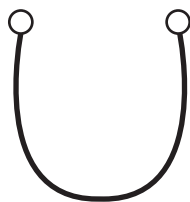

Theth

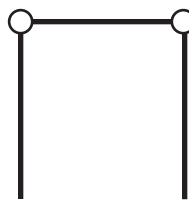

Cheth

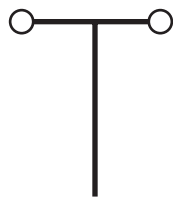

Zain



Vau

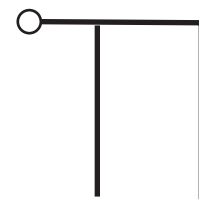

He

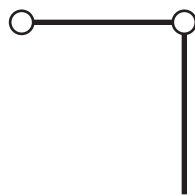

Daleth

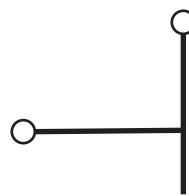

Gimel

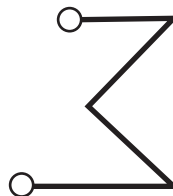

Beth

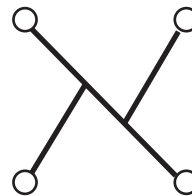

Aleph

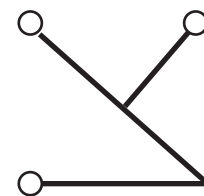

Zade



Pe

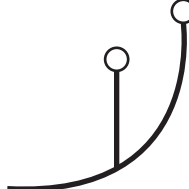

Ain

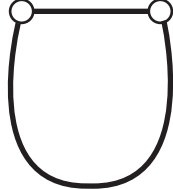

Samech

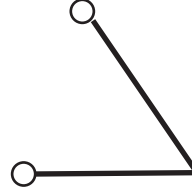

Nun

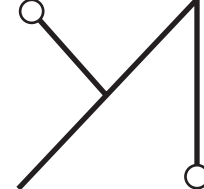

Mem

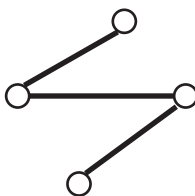

Lamed

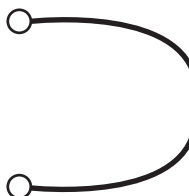

Caph

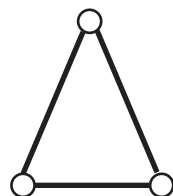

Jod

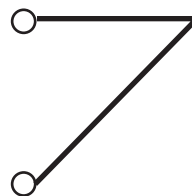

Tau

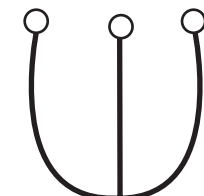

Shin

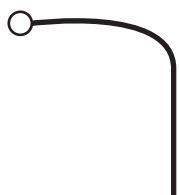

Res

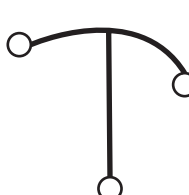

Kuff

Theban Alphabet also called Witches Alphabet

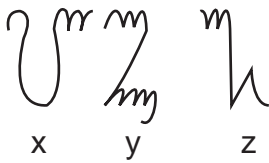
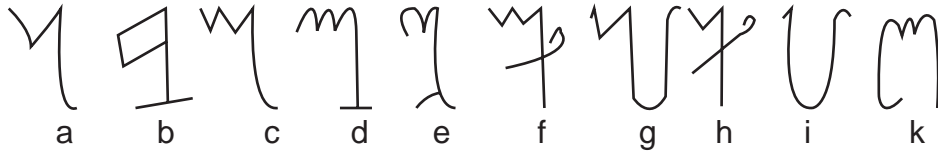

Mayan Numbers

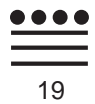

Coelbren Y Bierdd

Λ A ↓ W W < G ▽ > Δ
a â b v m c ch ngh d dd

← E K C X H I T N M
e ê f g ng h i l ll m

N O O P N M R K H ↑
n o ô p ph mh r rh s t

↑ N ↑ U W Y Y
th rh u w y y

Bobileth (a Celtic script)

ƚ ⊥ X ʒ F ʒ f ʌ ɛ ɔ
b l f s n d t c m g

9 A X Y Ǝ ≡
r a o u e j

Gothic Alphabet

f

u

th

a

r

c

g

w

h

n

i

j

z

p

x

s

t

b

e

m

l

ng

o

d

q

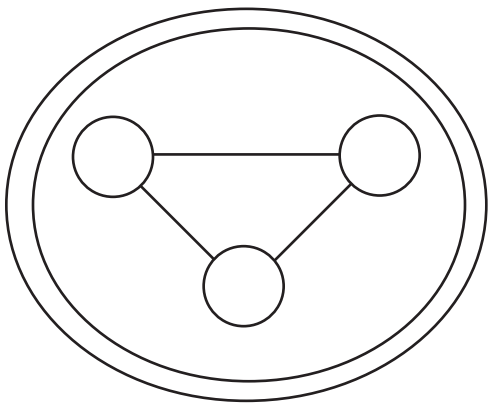

Images can easily be increased in size by photocopying or scanning.

Elder Futhark Runes

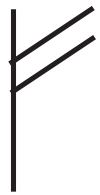

F
Fehu



H
Hagalaz



S
Sowilo



O
Othala



U
Uruz



N
Nauthiz



T
Tiwaz



D
Dagaz

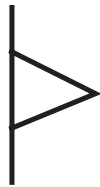

Th
Thurisaz



I
Isa



B
Birkana



A
Ansuz



J
Jera

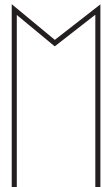

E
Ehwaz



R
Raidho



EO or Z
Eihwaz



M
Mannaz



K
Kenaz



P
Perthro



L
Laguz



G
Gebo



X or Z
Algiz



Ng
Ingwaz



W
Wunjo

The Younger Futhork



f



u



th



a



r



k



h



n



i



a



s



t



b



m



l



y

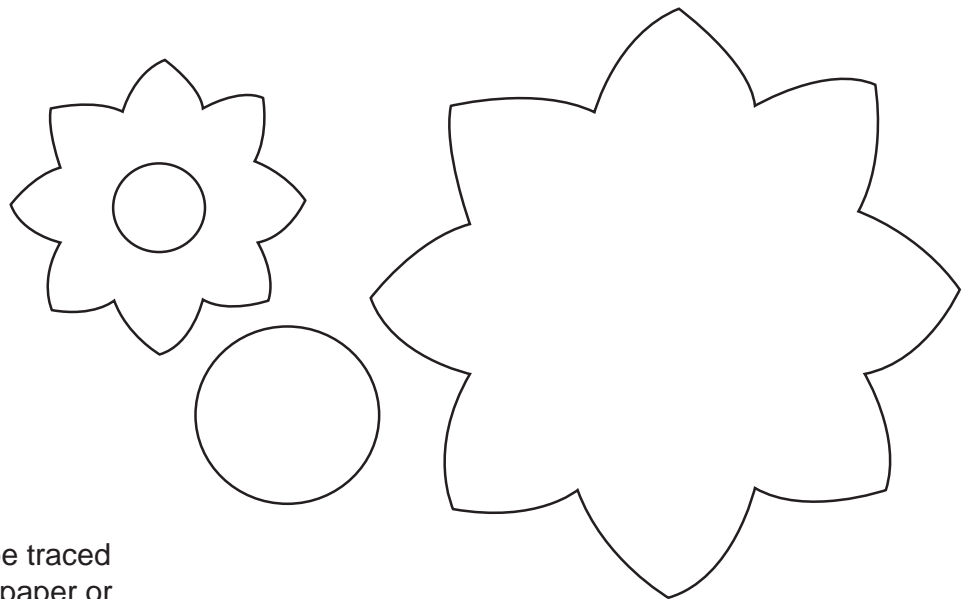

Images can be traced using tracing paper or they can be made onto hard surfaces using carbon paper.

Resources and Recommended Reading

Aldred, Cyril

1988 Akhenaten: King of Egypt. London: Thames and Hudson.

Ben-Tor, Amnon

1992 The Archaeology of Ancient Israel. Translated by R. Greenberg. Yale University Press.

Barrett, Francis

1967 The Magus. Secaucus, N.J.: The Citadel Press.

Chevalier, Jean

Gheerbrant, Alain

1996 The Penguin Dictionary of Symbols. Translated by John Buchanan-Brown. England: Penguin Books.

Dames, Michael

1992 Mythic Ireland. London: Thames and Hudson.

Frazer, Sir James George

1963 The Golden Bough. New York: Macmillan Publishing Company.

Gadon, Elinor W.

1989 The Once & Future Goddess. San Francisco: Harper Collins Publisher.

Gimbutas, Marija

1989 The Language of the Goddess. San Francisco: Harper Collins Publisher.

Grimal, Nicolas

1992 A History of Ancient Egypt. Cambridge, USA: Blackwell.

Meadows, Kenneth

1996 Rune Power: The Secret Knowledge of the Wise Ones. Boston, Massachusetts: Element.

Megaw, Ruth and Vincent

1989 Celtic Art: From Its Beginnings to the Book of Kells. London: Thames and Hudson.

Naylor, Maria

1975 Authentic Indian Designs. New York: Dover Publications, Inc.

Pennick, Nigel

1992 Magical Alphabets. York Beach, Maine: Samuel Weiser, Inc.

Raftery, Barry
1994 Pagan Celtic Ireland: The Enigma of the Irish Iron Age. London:
Thames and Hudson.

Scully, Vincent
1962 The Earth, The Temple, And The Gods: Greek Sacred Architecture. New
Haven: Yale University Press.

Sjoo, Monica
Mor, Barbara
1991 The Great Cosmic Mother: Rediscovering the Religion of the Earth.
San Francisco: Harper Collins Publisher.

Stone, George Cameron
1961 A Glossary of the Construction, Decoration and Use of Arms and
Armor In All Countries and In All Times. New York: Jack Brussel,
Publisher.

Walker, Barbara G.
1988 The Woman's Dictionary of Symbols & Sacred Objects. San Francisco:
Harper & Row, Publishers.

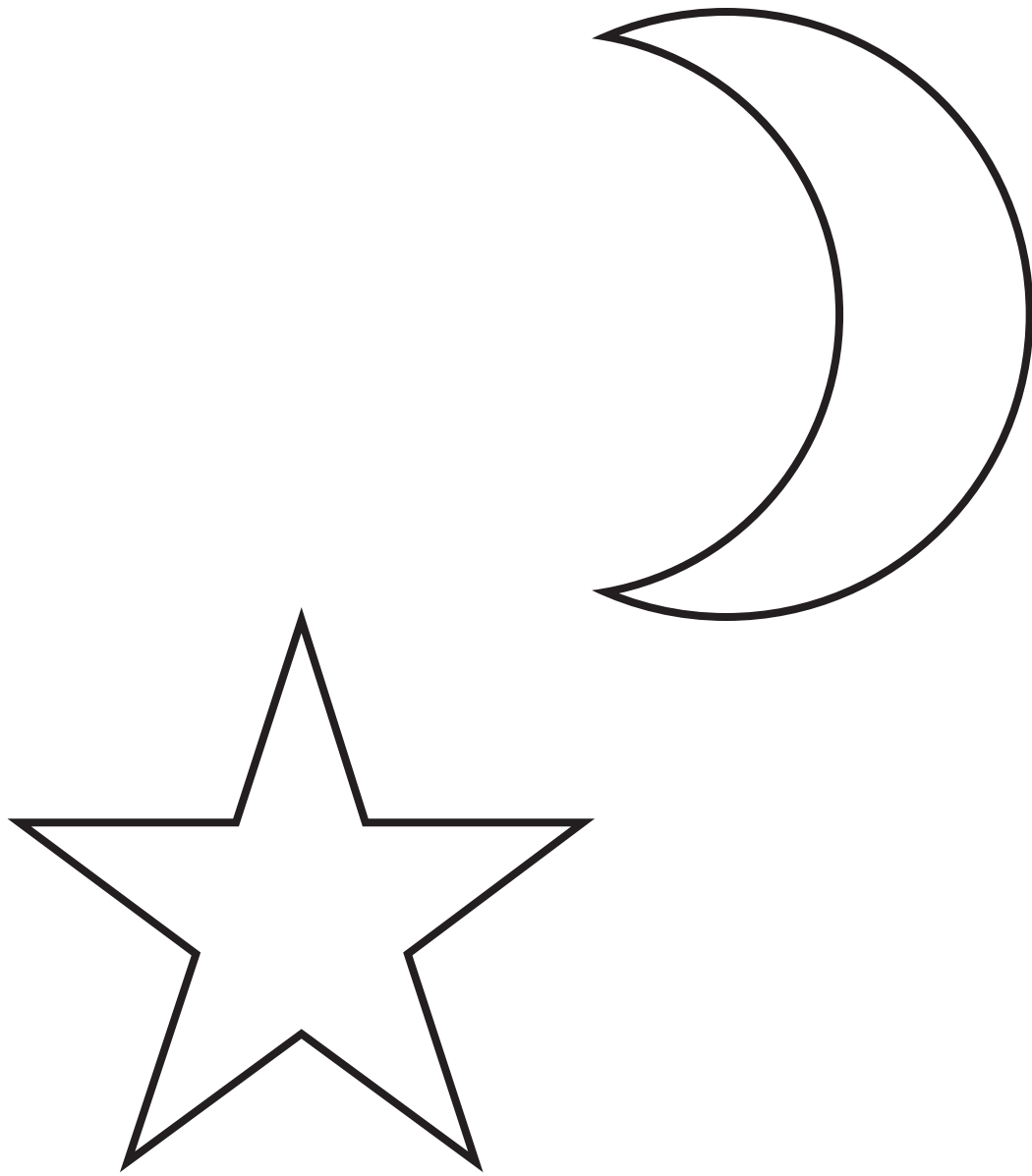

ISBN 1890846015



9 781890 846015 >

Copyright © 2000 Eliza Fegley
Published by Rowan Press, Inc.